

# **Wood-Mizer®**

## **Parts Manual**

---

**MP280**

**rev. A1.00**

---



**Safety is our #1 concern!** Read and understand all safety information and instructions before operating, setting up or maintaining this machine.

*Form #2522*

# Table of Contents

# Section-Page

<b>SECTION 1</b>	<b>GENERAL INFORMATION</b>	<b>1-1</b>
1.1	How To Use the Parts List.....	1-1
1.2	Sample Assembly .....	1-1
<b>SECTION 2</b>	<b>MP280 PLANER/MOULDER</b>	<b>2-1</b>
2.1	MP280 .....	2-1
2.2	Additional Parts Kit .....	2-2
2.3	Knives .....	2-3
2.4	Feet .....	2-4
2.5	Side Plates .....	2-5
<b>SECTION 3</b>	<b>MECHANICAL ASSEMBLY, MP280 PLANER/MOULDER</b>	<b>3-1</b>
3.1	Table .....	3-1
3.2	Right Spindle Assembly .....	3-3
3.3	Board Guide Assembly .....	3-4
3.4	Guide Assembly .....	3-5
3.5	Lower Cutter Assembly .....	3-6
3.6	Feed Assembly .....	3-7
3.7	Drive Shaft .....	3-8
3.8	Upper Cutter Assembly .....	3-9
3.9	Rod Set .....	3-10
3.10	Sawdust Outlets .....	3-11
3.11	Sawdust Outlet .....	3-12
3.12	Moving Spindle Assembly .....	3-13
3.13	Left Spindle Assembly .....	3-15
3.14	Clamp Roller Assembly .....	3-16
3.15	Trapezoidal Screw Assembly .....	3-17
3.16	Up/Down Assembly .....	3-18
3.17	Chain Guides .....	3-20
3.18	Anti-Kickback Fingers .....	3-21
3.19	Table .....	3-22
3.20	Clamp Roller Assembly (No. 533550) .....	3-24
<b>SECTION 4</b>	<b>GUARDS &amp; COVERS</b>	<b>4-1</b>
4.1	Right Cover .....	4-1
4.2	Top Cover .....	4-3
4.3	Right Cover .....	4-5
4.4	Front Cover .....	4-6
4.5	Moving Spindle Guard .....	4-7
4.6	Front Guard .....	4-8
4.7	Rear Guard .....	4-9
4.8	Sawdust Outlet .....	4-10

## Table of Contents

## Section-Page

4.9	Chain Guard .....	4-11	
<b>SECTION 5</b>	<b>MOTORS</b>		<b>5-1</b>
5.1	Motor Set, MP280EH 3x400V CE .....	5-1	
5.2	Spindle Drive Assembly .....	5-2	
5.3	Upper Cutter Drive Assembly .....	5-3	
5.4	Lower Cutter Drive Assembly .....	5-4	
5.5	Feed Drive Assembly .....	5-5	
5.6	Control Box Mount Bracket .....	5-6	
5.7	Control Box .....	5-7	
<b>SECTION 6</b>	<b>DECALS</b>		<b>6-1</b>
6.1	MP280 Decals .....	6-1	

## SECTION 1 GENERAL INFORMATION

### 1.1 How To Use the Parts List

- Use the index above to locate the assembly that contains the part you need.
- Go to the appropriate section and locate the part in the illustration.
- Use the number pointing to the part to locate the correct part number and description in the table.
- Parts shown indented under another part are included with that part.
- Parts marked with a diamond (◆) are only available in the assembly listed above the part.

See the sample table below. Sample Part #A01111 includes part F02222-2 and subassembly A03333. Subassembly A03333 includes part S04444-4 and subassembly K05555. The diamond (◆) indicates that S04444-4 is not available except in subassembly A03333. Subassembly K05555 includes parts M06666 and F07777-77. The diamond (◆) indicates M06666 is not available except in subassembly K05555.

1.2 Sample Assembly				
REF.	DESCRIPTION (◆ Indicates Parts Available In Assemblies Only)	PART #	QTY	
	Sample Assembly, Complete (Includes All Indented Parts Below)	A01111	1	
1	Sample Part	F02222-22	1	
	Sample Subassembly (Includes All Indented Parts Below)	A03333	1	
2	Sample Part (◆ Indicates Part Is Only Available With A03333)	S04444-4	1	◆
	Sample Subassembly (Includes All Indented Parts Below)	K05555	1	
3	Sample Part (◆ Indicates Part Is Only Available With K05555)	M06666	2	◆
4	Sample Part	F07777-77	1	

#### To Order Parts:

- From Europe call our European Headquarters and Manufacturing Facility in Kolo, Poland at **+48-63-2626000**. From the continental U.S., call our toll-free Parts hotline at **1-800-525-8100**. Have your customer number, vehicle identification number, and part numbers ready when you call. From other international locations, contact the Wood-Mizer distributor in your area for parts.

#### Office Hours:

Country	Monday - Friday	Saturday	Sunday
Poland	7-15	Closed	Closed
US	8 a.m.- 5 p.m.	8 a.m.- 12 p.m.	Closed



**CAUTION!** It is strongly recommended that only original spare parts be used.

## SECTION 2 MP280 PLANER/MOULDER

### 2.1 MP280

MP280EH13S-V\_001  
MP280EH13S-V

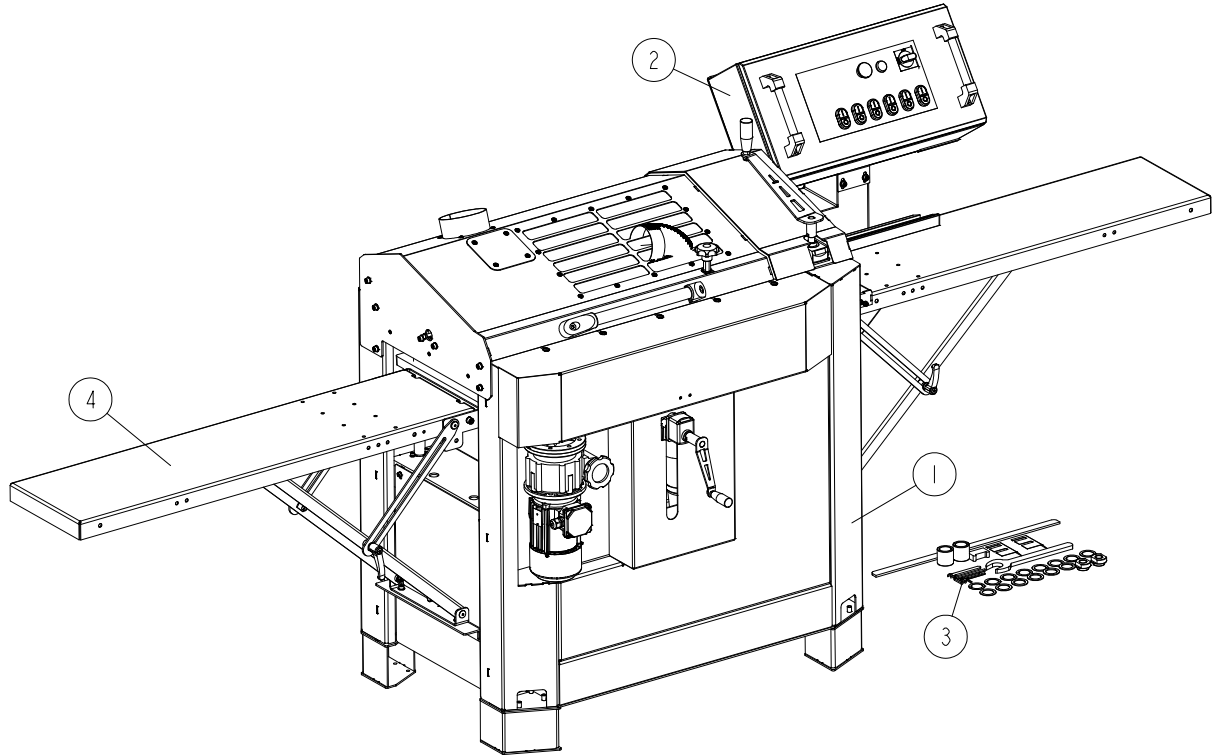

REF.	DESCRIPTION (* indicates parts available in assemblies only)	PART #	QTY
-	<b>MP280 PLANER/MOULDER</b>		1
1	MP280 MECHANICAL ASSEMBLY <a href="#">See SECTION 3</a>	537233	1
2	MOTOR KIT, PRO MP280EH 3X400V CE <a href="#">See Section 5.1</a>	541139	1
3	PARTS KIT, MP280 ADDITIONAL <a href="#">See Section 2.2</a>	546930	1
4	TABLE, MP280 <a href="#">See Section 3.19</a>	546941	2

## 2 MP280 Planer/Moulder

### Additional Parts Kit

## 2.2 Additional Parts Kit

MP280EH13S-V\_002  
MP280EH13S-V

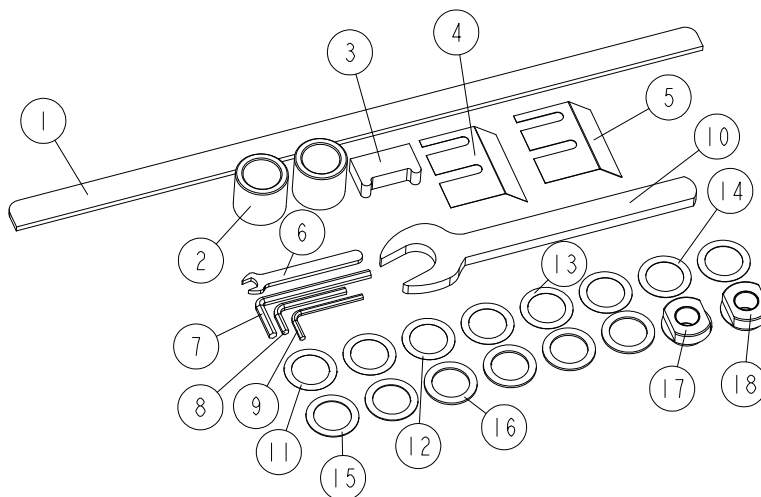

REF.	DESCRIPTION (* indicates parts available in assemblies only)	PART #	QTY
-	<b>PARTS KIT, MP280 ADDITIONAL</b>	546930	1
1	BAR, FENCE ADJUSTMENT	360-911	1
2	BUSHING, 30/42-40.2 ZINC-PLATED	535848-1	2
3	TOOL, KNIFE SETTING	534770	1
4	PLATE, 0.3 MM CHIP BREAKER	537648	1
5	PLATE, 0.5 MM CHIP BREAKER	533502	1
-	WRENCH SET	535185	1
6	WRENCH, 10 OPEN-END	541315	1
7	WRENCH, 6 MM ALLEN	535186	1
8	WRENCH, 5 ALLEN	092915	1
9	WRENCH, 4MM ALLEN	093368	1
10	WRENCH, 30 DIN 894 OPEN ENDED	537649	1
11	SHIM, 30/42-0.1 FE/ZN5 DIN988	F81069-6	2
12	SHIM, 30/42-0.2 FE/ZN5 DIN988	F81069-5	2
13	SHIM, 30/42-0.3 FE/ZN5 DIN 988	F81069-4	2
14	SHIM, 30/42-0.5 FE/ZN5 DIN 988	F81069-3	2
15	SHIM, 30/42-1 FE/ZN5 DIN 988	F81069-2	2
16	SHIM, 30/42-2 FE/ZN5 DIN 988	F81069-1	4
17	NUT, M20X1.5	542620-1	1
18	NUT, M20X1.5 LEFT	542621-1	1

## 2.3 Knives

MP280EH13S-V\_003  
MP280EH13S-V

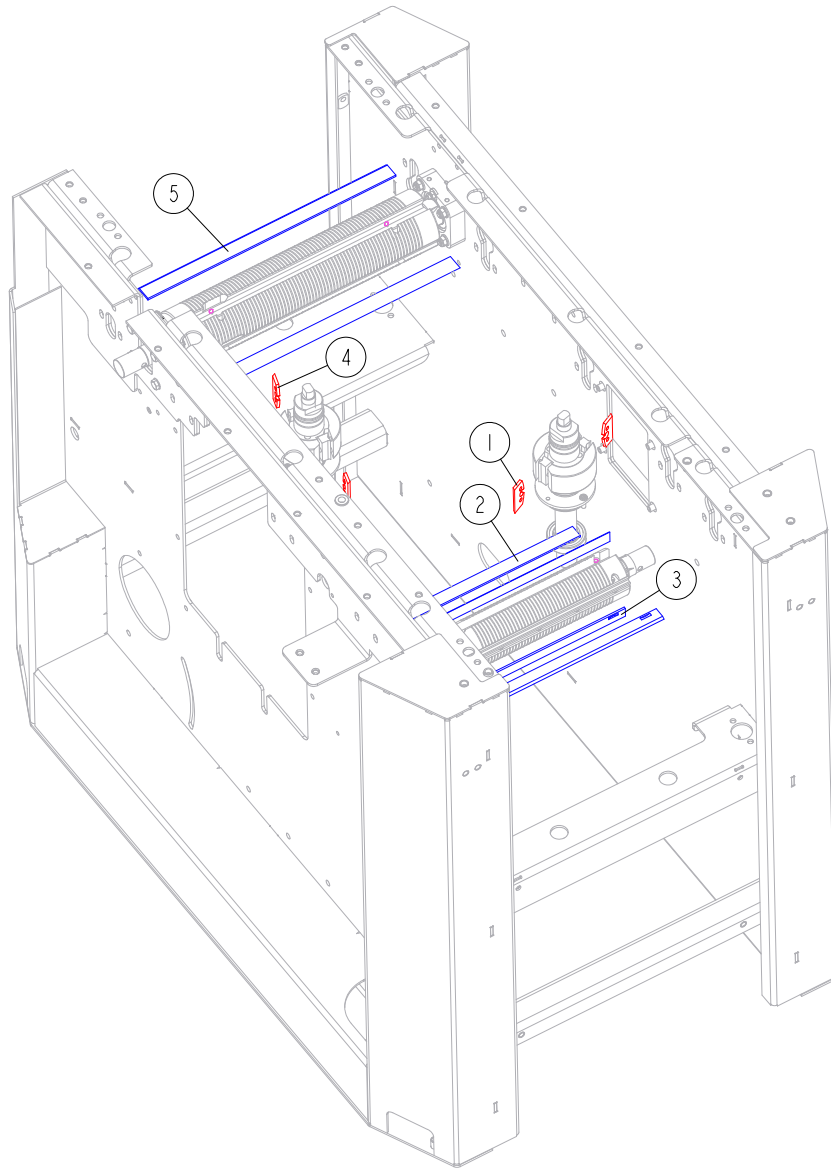

REF.	DESCRIPTION (* indicates parts available in assemblies only)	PART #	QTY
1	KNIFE, CUTTER	533588	2
2	KNIFE, PLANING	TPK30020MP	2
3	KNIFE, PLANING	TPK30020MP	2
4	KNIFE, CUTTER	533588	2
-	KNIFE SET, PLANING	TPK41025MP	1
5	TPK510.25HS	TPK41025HS	2

**2.4 Foots**

MP280EH13S-V\_004  
 MP280EH13S-V

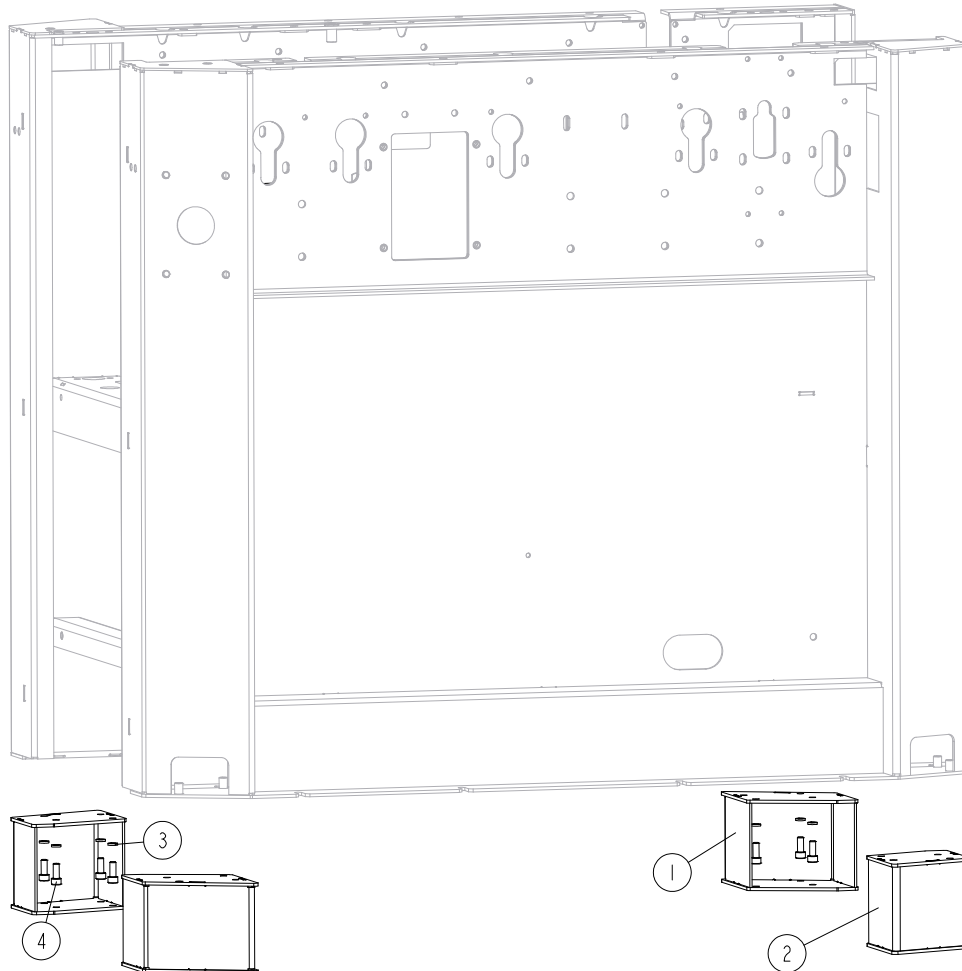

REF.	DESCRIPTION (* indicates parts available in assemblies only)	PART #	QTY
1	MP280 FOOT (1)	546888-1	3
2	MP280 FOOT (2)	546893-1	1
3	WASHER, 8.2 SPLIT LOCK ZINC	F81054-4	16
4	SCREW, M8X20-8.8 HEX SOCKET HEAD CAP ZINC	F81002-30	16



## 2.5 Side Plates

MP280EH13S-V\_005  
MP280EH13S-V

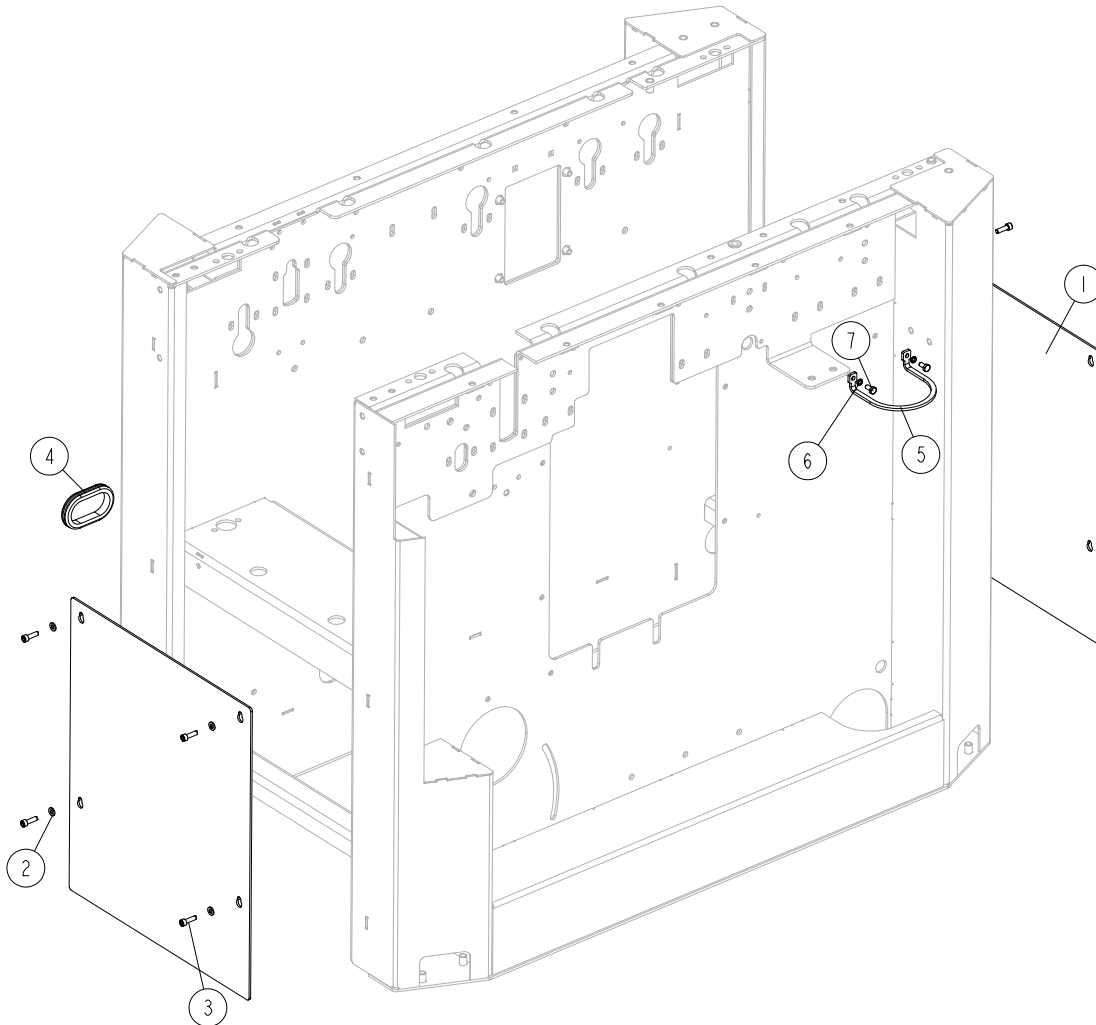

REF.	DESCRIPTION (* indicates parts available in assemblies only)	PART #	QTY	
1	PLATE, SIDE	561855-1	2	
2	WASHER, 6.4 FLAT ZINC	F81053-1	8	
3	SCREW, M6X20 8.8 HEX SOCKET HEAD CAP ZINC	F81001-22	8	
4	GROMMET, RUBBER	087065	1	
5	U-BOLT, MP280	562014-1	1	
6	WASHER, Z 6.1 SPLIT LOCK ZINC	F81053-3	2	
7	BOLT, M6X12 8.8 HEX HEAD FULL THREAD ZINC	F81001-7	2	

## SECTION 3 MECHANICAL ASSEMBLY, MP280 PLANER/MOULDER

### 3.1 Table

MP280EH13S-V\_006  
MP280EH13S-V

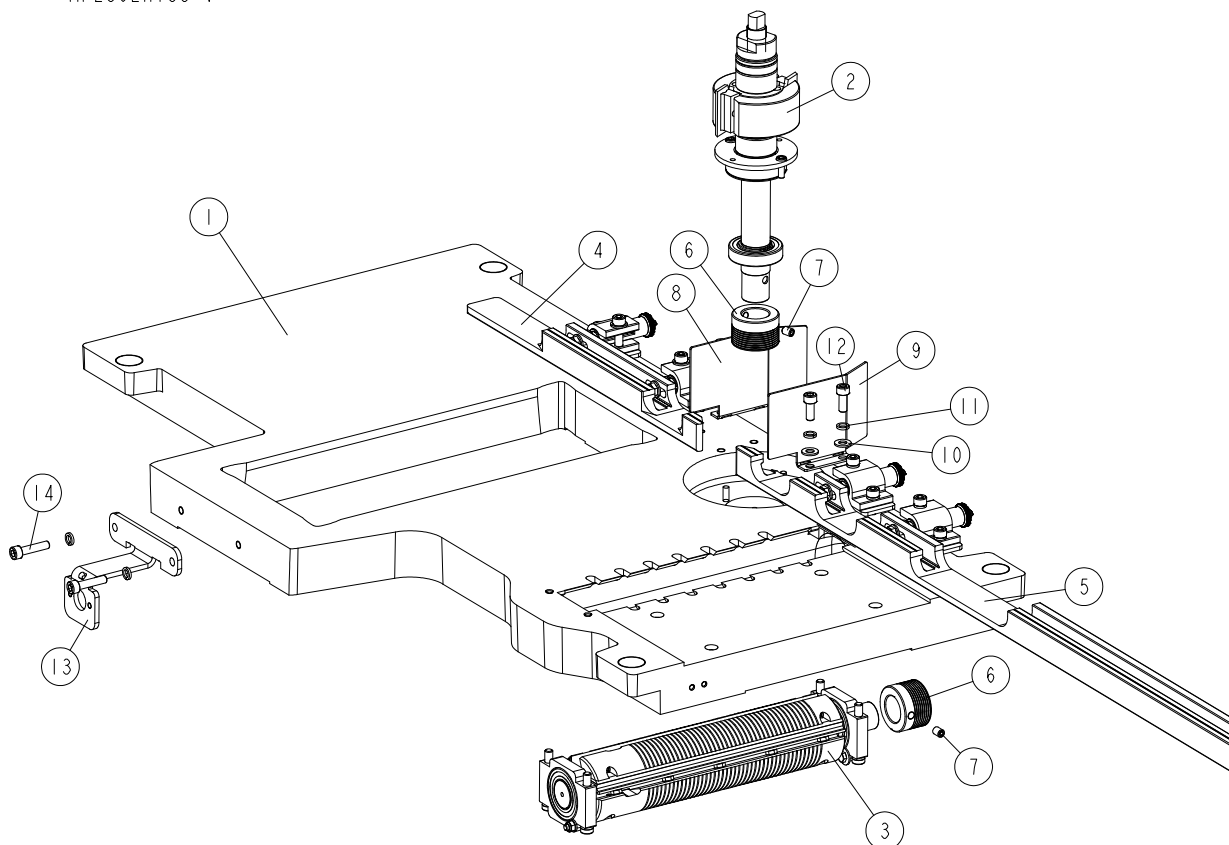

REF.	DESCRIPTION (* indicates parts available in assemblies only)	PART #	QTY
-	<b>TABLE, MP280 COMPLETE</b>	537261	1
1	TABLE, MP280	562040-1	1
2	SPINDLE ASSEMBLY, RIGHT <a href="#">See Section 3.2</a>	537135	1
3	CUTTER ASSEMBLY, LOWER <a href="#">See Section 3.5</a>	537568	1
4	COMPLETE GUIDE (2) <a href="#">See Section 3.3</a>	536963	1
5	GUIDE ASSEMBLY <a href="#">See Section 3.4</a>	541148	1
6	SHEAVE, MULTI-GROOVE SMALL	533586	2
7	SCREW, M8X12-45H FE/ZN DIN914 HEX SOCKET SET W/CONE POINT	F81002-105	2
8	GUARD, CUTTER (1)	537006	1
9	GUARD, CUTTER (2)	537007	1
10	WASHER, 8.4 FLAT ZINC	F81054-1	4
11	WASHER, 8.2 SPLIT LOCK ZINC	F81054-4	6
12	SCREW, M8X20-8.8 HEX SOCKET HEAD CAP ZINC	F81002-30	4

# Mechanical Assembly, MP280 Planer/Moulder

Table

3

REF.	DESCRIPTION (* indicates parts available in assemblies only)	PART #	QTY	
13	PLATE, POSITION INDICATOR MOUNT	561851-1	1	
14	SCREW, M8X35-8.8 HEX SOCKET HEAD CAP ZINC	F81002-58	2	

**3.2 Right Spindle Assembly**

MP280EH13S-V\_007  
 MP280EH13S-V

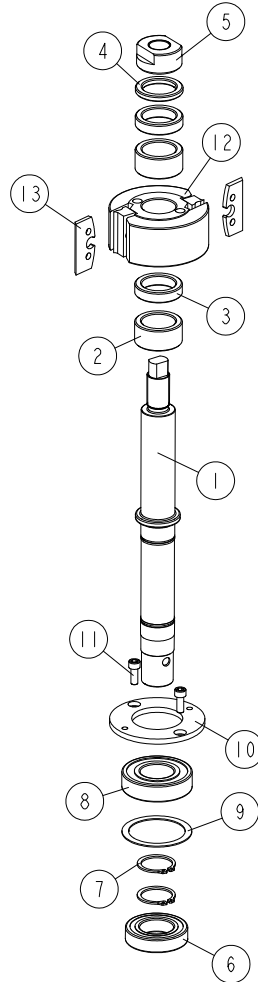

REF.	DESCRIPTION (* indicates parts available in assemblies only)	PART #	QTY
-	<b>SPINDLE ASSEMBLY, RIGHT</b>	537135	1
1	SPINDLE	537134	1
2	BUSHING, 30/42-20.2 ZINC-PLATED	533541-1	2
3	BUSHING, 30/42-10 ZINC-PLATED	533539-1	2
4	BUSHING, 30/42-5.2 ZINC-PLATED	533540-1	1
5	NUT, M20X1.5	535886-1	1
6	BEARING, 6006 2RSR	096191	1
7	RING, Z30 OUTSIDE RETAINING	F81090-23	2
8	BEARING, 6206 2RSR P6 ROLLING (FAG, NSK, SKF)	100787	1
9	WASHER, 50X61.6X1	533543	1
10	PLATE, CLAMPING	533542-1	1
11	SCREW, M6X16 8.8 HEX SOCKET HEAD CAP ZINC	F81001-21	2
-	CUTTERHEAD	TG562K	1
12	CUTTERHEAD	533587	1
13	KNIFE, CUTTER	533588	2

### 3.3 Board Guide Assembly

MP280EH13S-V\_008  
MP280EH13S-V

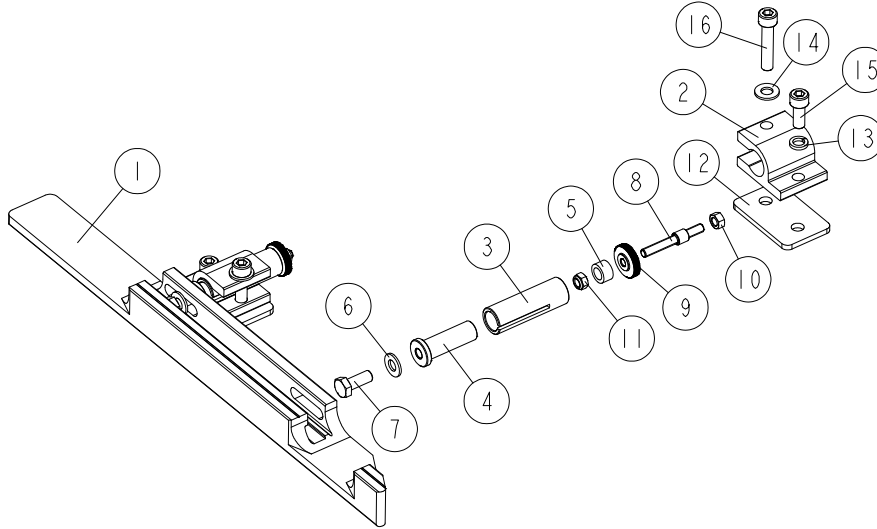

REF.	DESCRIPTION (* indicates parts available in assemblies only)	PART #	QTY
-	COMPLETE BOARD GUIDE (2)	536963	1
1	GUIDE (2)	536962-1	1
2	CLAMP	536966-1	2
-	ADJUSTABLE KNOB	536965	2
3	GUIDE, PIN	537001-1	1
4	PIN, ADJUSTABLE KNOB	536999-1	1
5	INSERT	537002	1
6	WASHER, 8.4 FLAT ZINC	F81054-1	1
7	BOLT, M8X20 8.8 HEX HEAD FULL THREAD ZINC	F81002-4	1
8	PIN, M6 THREADED	541455	1
9	NUT, FLAT KNURLED	541454	1
10	NUT, M6 8 HEX ZINC	F81031-1	1
11	NUT, M6-8-B HEX NYLON ZINC LOCK	F81031-2	1
12	PLATE, MOUNT	536968-1	2
13	WASHER, 8.2 SPLIT LOCK ZINC	F81054-4	2
14	WASHER, 8.4 FLAT ZINC	F81054-1	2
15	SCREW, M8X20-8.8 HEX SOCKET HEAD CAP ZINC	F81002-30	2
16	SCREW, M8X40-8.8 HEX SOCKET HEAD CAP ZINC	F81002-29	2

### 3.4 Guide Assembly

MP280EH13S-V\_009  
MP280EH13S-V

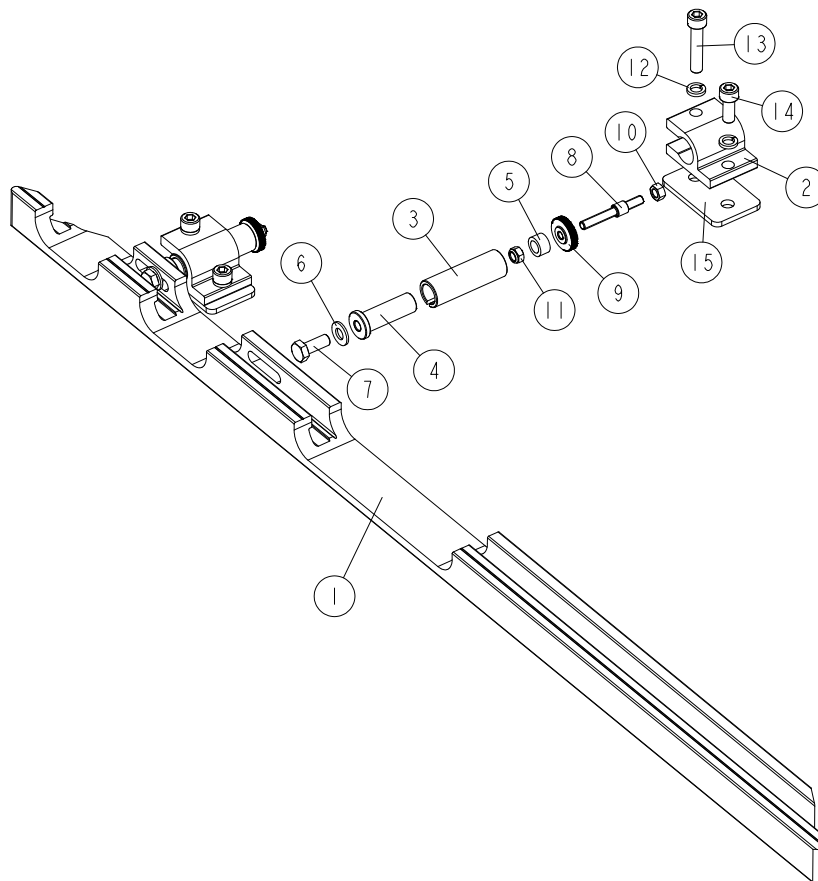

REF.	DESCRIPTION (* indicates parts available in assemblies only)	PART #	QTY
-	<b>GUIDE ASSEMBLY</b>	541148	1
1	GUIDE, 900MM MP280	564952-1	1
2	CLAMP	536966-1	2
-	ADJUSTABLE KNOB	536965	2
3	GUIDE, PIN	537001-1	1
4	PIN, ADJUSTABLE KNOB	536999-1	1
5	INSERT	537002	1
6	WASHER, 8.4 FLAT ZINC	F81054-1	1
7	BOLT, M8X20 8.8 HEX HEAD FULL THREAD ZINC	F81002-4	1
8	PIN, M6 THREADED	541455	1
9	NUT, FLAT KNURLED	541454	1
10	NUT, M6 8 HEX ZINC	F81031-1	1
11	NUT, M6-8-B HEX NYLON ZINC LOCK	F81031-2	1
12	WASHER, 8.2 SPLIT LOCK ZINC	F81054-4	4
13	SCREW, M8X40-8.8 HEX SOCKET HEAD CAP ZINC	F81002-29	2
14	SCREW, M8X20-8.8 HEX SOCKET HEAD CAP ZINC	F81002-30	2
15	PLATE, MOUNT	536968-1	2

### 3.5 Lower Cutter Assembly

MP280EH13S-V\_010  
 MP280EH13S-V

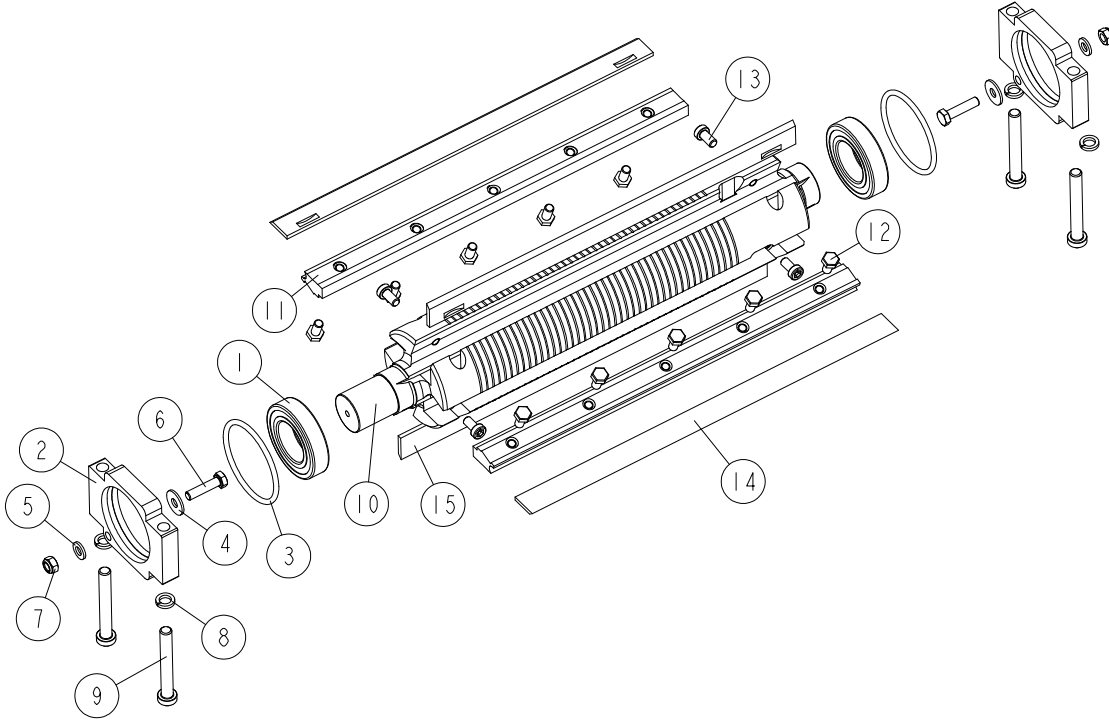

REF.	DESCRIPTION (* indicates parts available in assemblies only)	PART #	QTY
-	<b>CUTTER ASSEMBLY, LOWER</b>	537568	1
1	BEARING, 6006 2RSR	096191	2
2	HOUSING, BEARING (1)	536958-1	2
3	O-RING	536959	2
4	WASHER, 6.5 SPECIAL FLAT ZINC	F81053-11	2
5	WASHER, 6.4 FLAT ZINC	F81053-1	2
6	BOLT, M6X25 -8.8 HEX HEAD FULL THREAD ZINC	F81001-3	2
7	NUT, M6-8-B HEX NYLON ZINC LOCK	F81031-2	2
8	WASHER, 8.2 SPLIT LOCK ZINC	F81054-4	4
9	SCREW, M8X60-8.8 DIN7984 HEX SOCKET HEAD CAP	F81002-41	4
-	CUTTER, MP260 BC	564946	1
10	CUTTER, SMALL	260-140-5	1
11	WEDGE SET, MOUNTING	241-061	1
12	BOLT, M6X12 10.9 DIN933 ISO4017 HEX HEAD	083595	10
13	SCREW, M6X12-10.9 DIN 7984 HEX SOCKET THIN HEAD CAP	F81001-80	4
14	KNIFE, PLANING	TPK30020MP	2
15	<b>KNIFE, PLANING</b>	TPK30020MP	2

### 3.6 Feed Assembly

MP280EH13S-V-011  
MP280EH13S-V

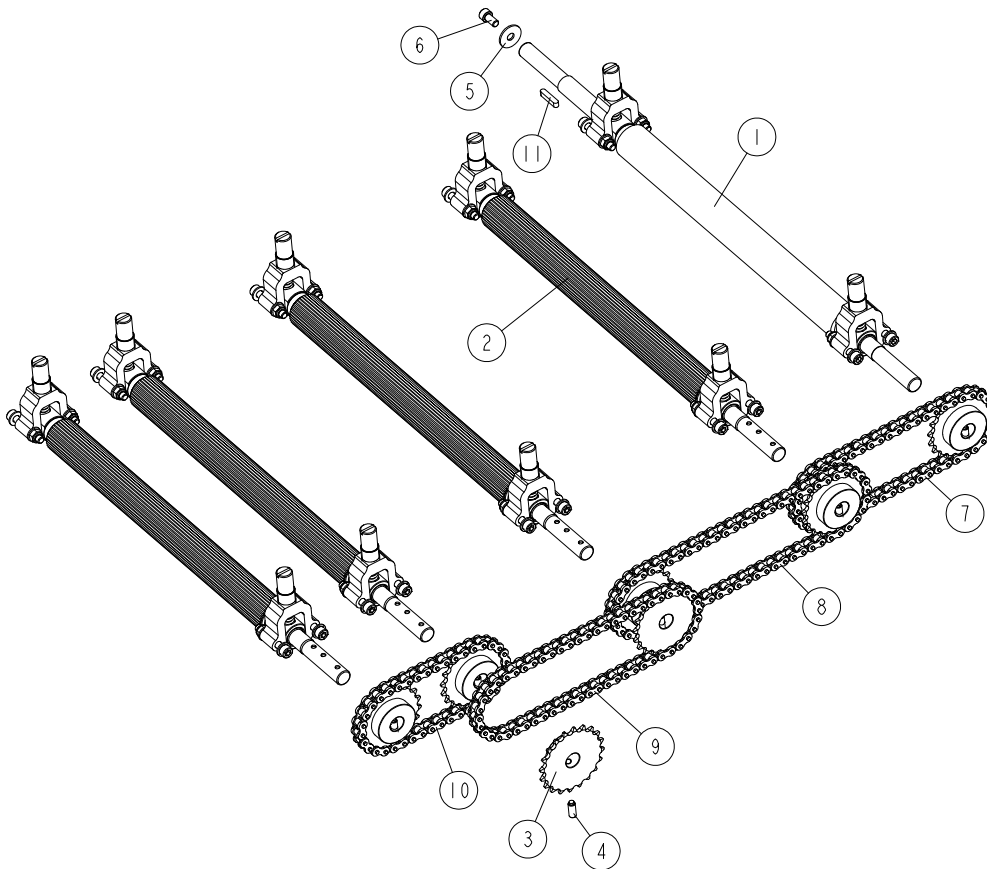

REF.	DESCRIPTION (* indicates parts available in assemblies only)	PART #	QTY
-	<b>FEED ASSEMBLY, MP280</b>	537234	1
1	SHAFT ASSEMBLY, W/PROTECTIVE COVER <a href="#">See Section 3.7</a>	537239	1
2	SHAFT ASSEMBLY, DRIVE <a href="#">See Section 3.7</a>	537242	4
3	SPROCKET, Z=20; 1/2"X 3/16" (CHAIN 083-1)	535832	8
4	SCREW, M8X20 -45H- PN-EN-ISO 4028 ; DIN915 HEX SOCKET SET W/DOG POINT	F81002-77	8
5	WASHER, 9/28-2	535853-1	1
6	SCREW, M8X16-8.8 HEX SOCKET HEAD CAP ZINC	F81002-39	1
7	CHAIN	541286	1
8	CHAIN	541287	1
9	CHAIN	541288	1
10	CHAIN	541289	1
11	KEY, A6X6X30 PARALLEL	094245	1



3.7 Drive Shaft

MP280EH13S-V\_012  
 MP280EH13S-V

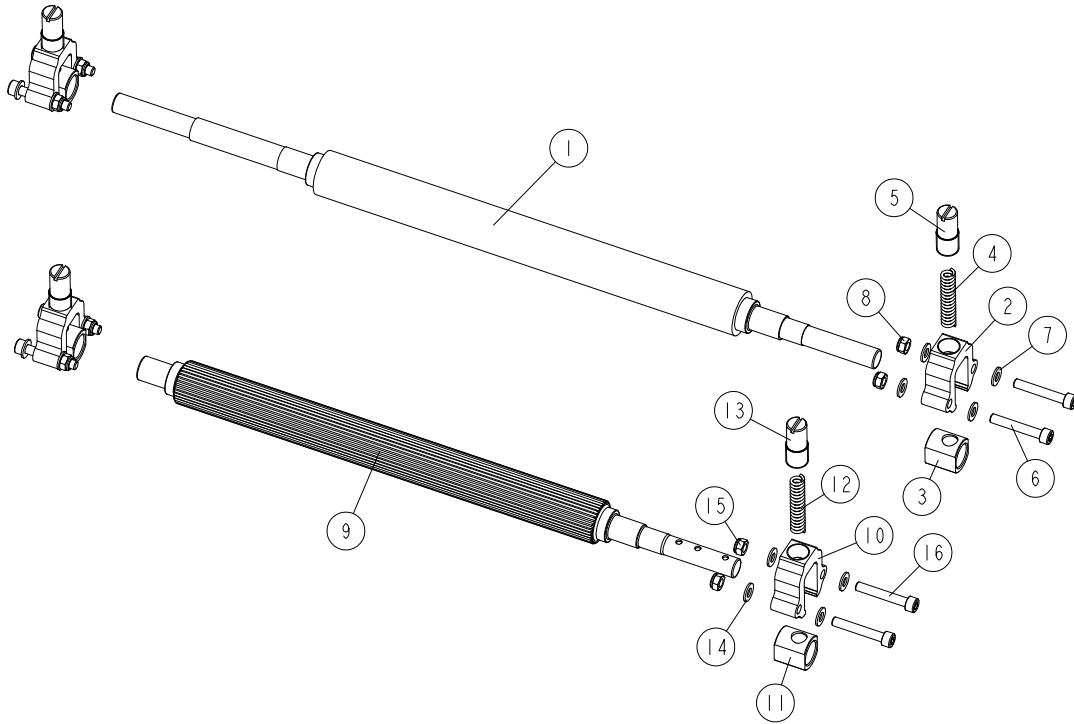

REF.	DESCRIPTION (* indicates parts available in assemblies only)	PART #	QTY
-	<b>SHAFT ASSEMBLY, W/PROTECTIVE COVER</b>	537239	1
1	SHAFT W/PROTECTIVE COVER	537240	1
-	HOUSING, BEARING - COMPLETE	535737	2
2	HOUSING, SLIDE BUSHING	535733-1	1
3	BUSHING, SLIDE	546899	1
4	SPRING	535736-1	1
5	SCREW, ADJUSTMENT	535734-1	1
6	SCREW, M8X50-8.8 HEX SOCKET HEAD CAP ZINC	F81002-85	4
7	WASHER, 8.4 FLAT ZINC	F81054-1	8
8	NUT, M8-8-B HEX NYLON ZINC LOCK	F81032-2	4
-	<b>SHAFT ASSEMBLY, DRIVE</b>	537242	1
9	SHAFT, STEEL DRIVE	537243-1	1
-	HOUSING, BEARING - COMPLETE	535737	2
10	HOUSING, SLIDE BUSHING	535733-1	1
11	BUSHING, SLIDE	546899	1
12	SPRING	535736-1	1
13	SCREW, ADJUSTMENT	535734-1	1
14	WASHER, 8.4 FLAT ZINC	F81054-1	8
15	NUT, M8-8-B HEX NYLON ZINC LOCK	F81032-2	4
16	SCREW, M8X50-8.8 HEX SOCKET HEAD CAP ZINC	F81002-85	4

# 3 Mechanical Assembly, MP280 Planer/Moulder

## Upper Cutter Assembly

### 3.8 Upper Cutter Assembly

MP280EH13S-V\_037  
MP280EH13S-V

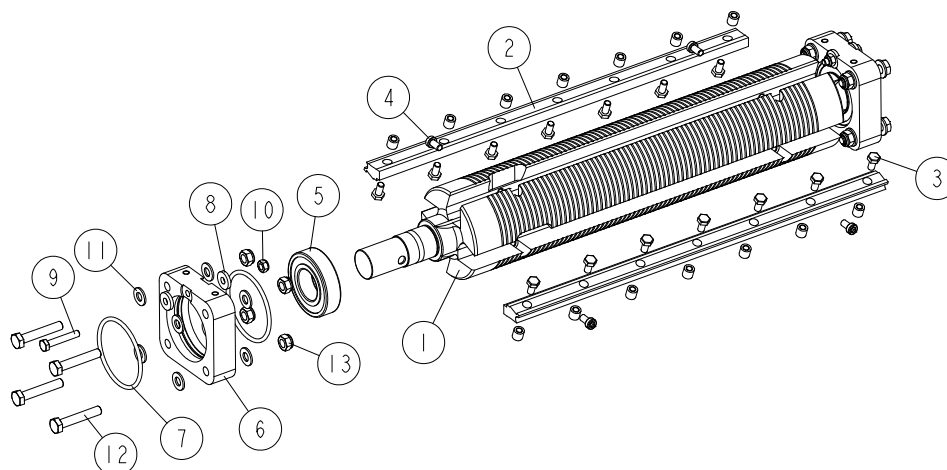

REF.	DESCRIPTION (* indicates parts available in assemblies only)	PART #	QTY
-	<b>CUTTER ASSEMBLY, UPPER</b>	537235	1
1	CUTTER, UPPER	537236	1
2	WEDGE SET, MOUNTING	537237	1
3	BOLT, M6X12 10.9 DIN933 ISO4017 HEX HEAD	083595	14
4	SCREW, M6X12-10.9 DIN 7984 HEX SOCKET THIN HEAD CAP	F81001-80	4
5	BEARING, 6206 2RSR P6 ROLLING (FAG, NSK, SKF)	100787	2
-	HOUSING ASSEMBLY, BEARING	536964	2
6	HOUSING, BEARING	533590-1	1
7	O-RING, BEARING HOUSING	533592	2
8	WASHER, 6.4 FE/ZN DIN 7349 SPACER	F81053-13	2
9	BOLT, M6X35-8.8 HEX HEAD ZINC	F81001-71	1
10	NUT, M6-8-B HEX NYLON ZINC LOCK	F81031-2	1
11	WASHER, 8.4 FLAT ZINC	F81054-1	8
12	BOLT, M8X45-8.8 HEX HEAD FULL THREAD ZINC	F81002-14	4
13	NUT, M8-8-B HEX NYLON ZINC LOCK	F81032-2	4

3.9 Rod Set

MP280EH13S-V\_022  
MP280EH13S-V

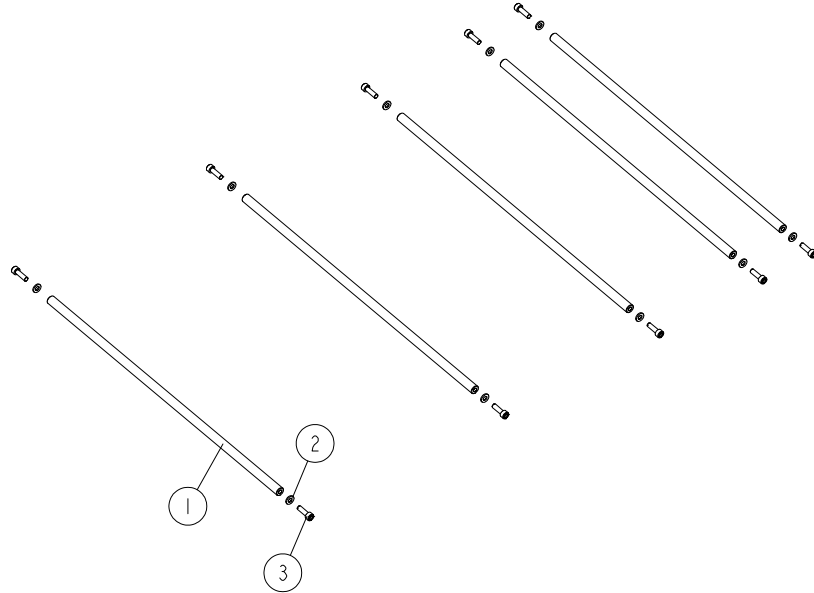

REF.	DESCRIPTION (* indicates parts available in assemblies only)	PART #	QTY
-	ROD SET	541312	1
1	SHAFT	533092-1	5
2	WASHER, 6.4 FLAT ZINC	F81053-1	10
3	SCREW, M6X20 8.8 HEX SOCKET HEAD CAP ZINC	F81001-22	10

### 3.10 Sawdust Outlets

MP280EH13S-V\_023  
MP280EH13S-V

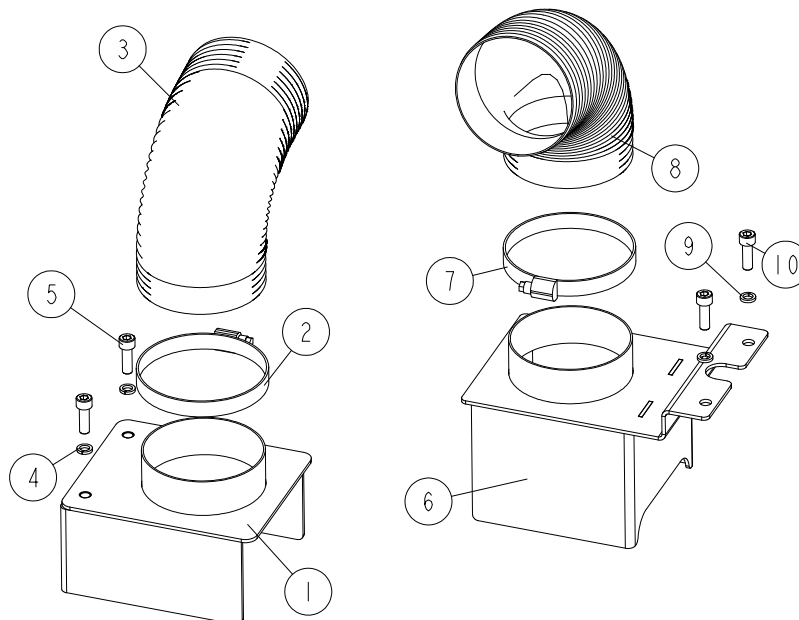

REF.	DESCRIPTION (* indicates parts available in assemblies only)	PART #	QTY
-	<b>OUTLET SET, SAWDUST</b>	561885	1
1	OUTLET WELDMENT, SAWDUST	561883-1	1
2	CLAMP, 90-110 MM	F81095-8	1
3	HOSE, MASTER CLIP PUR DN100 400 MM SAWDUST OUTLET	561988	1
4	WASHER, 8.2 SPLIT LOCK ZINC	F81054-4	2
5	SCREW, M8X25-8.8 HEX SOCKET HEAD CAP ZINC	F81002-21	2
-	<b>OUTLET SET, SAWDUST</b>	561900	1
6	OUTLET WELDMENT, SAWDUST	561899-1	1
7	CLAMP, 90-110 MM	F81095-8	1
8	HOSE, MASTER CLIP PUR DN100 700 MM SAWDUST OUTLET	561886	1
9	WASHER, 8.2 SPLIT LOCK ZINC	F81054-4	2
10	SCREW, M8X25-8.8 HEX SOCKET HEAD CAP ZINC	F81002-21	2

### 3.11 Sawdust Outlet

MP280EH13S-V\_024  
MP280EH13S-V

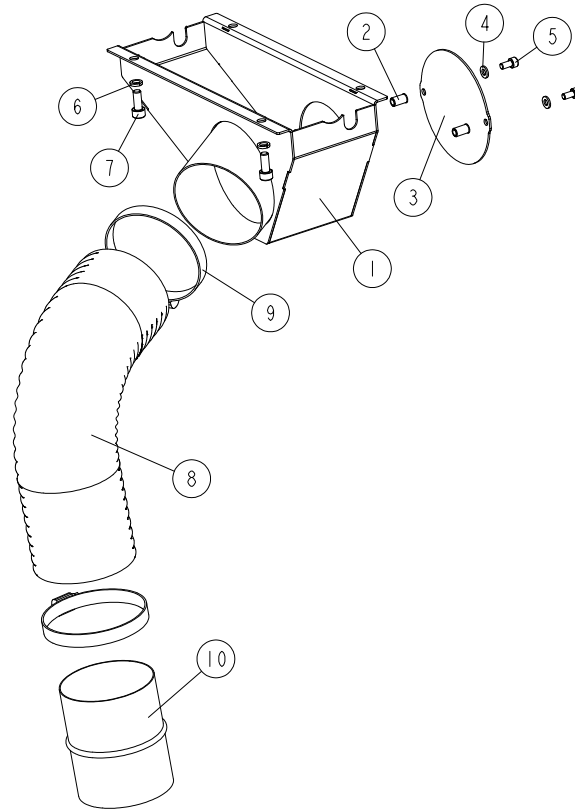

REF.	DESCRIPTION (* indicates parts available in assemblies only)	PART #	QTY
-	<b>OUTLET, SAWDUST - COMPLETE</b>	546865	1
1	OUTLET WELDMENT, SAWDUST	537546-1	1
2	NUT, M6 1.5-4.0 MIN MTRG ZINC STEEL RIVET	F81031-13	2
3	COVER	537543-1	1
4	WASHER, 6.4 FLAT ZINC	F81053-1	2
5	SCREW, M6X12-8.8-A2E ISO 4762 HEX SOCKET HEAD CAP	F81001-87	2
6	WASHER, 8.2 SPLIT LOCK ZINC	F81054-4	4
7	SCREW, M8X20-8.8 HEX SOCKET HEAD CAP ZINC	F81002-30	4
8	HOSE, MASTER CLIP PUR DN100 L=700 MM SAWDUST OUTLET	546803	1
9	CLAMP, 90-110 MM	F81095-8	2
10	PIPE, DN 100 STRAIGHT CONNECTION	546804	1

### 3.12 Moving Spindle Assembly

MP280EH13S-V\_025  
 MP280EH13S-V

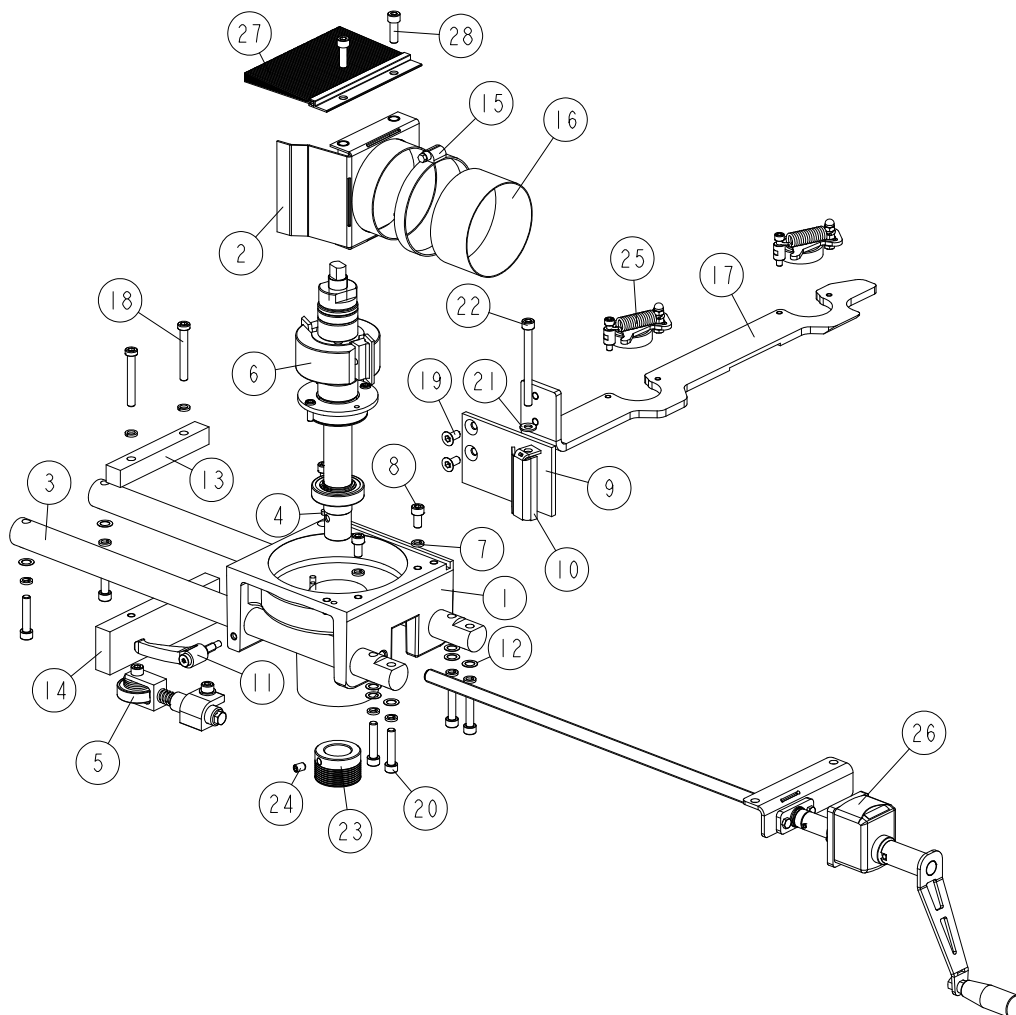

REF.	DESCRIPTION (* indicates parts available in assemblies only)	PART #	QTY
-	<b>SPINDLE ASSEMBLY, MOVING</b>	541137	1
1	MOUNT WELDMENT, SPINDLE	546837-1	1
2	OUTLET WELDMENT, SAWDUST	537028-1	1
3	ROD, LEFT SPINDLE GUIDE	541262	2
4	SLIDE	535987	2
5	ROLLER ASSEMBLY, CLAMP II <a href="#">See Section 3.20</a>	533550	1
6	SPINDLE ASSEMBLY, LEFT <a href="#">See Section 3.13</a>	537005	1
7	WASHER, 8.2 SPLIT LOCK ZINC	F81054-4	10
8	SCREW, M8X16-8.8 HEX SOCKET HEAD CAP ZINC	F81002-39	2
9	PLATE, MOUNT	537027-1	1
10	BRACKET, GUIDE MOUNT	535984-1	1
11	HANDLE, ERZ.63 P-M8X16 ADJUSTABLE	535988	1
12	WASHER, 10/16-0.5 THIN	535990	8
13	BLOCK, GUIDE (1)	536956-1	1

# Mechanical Assembly, MP280 Planer/Moulder

## Moving Spindle Assembly

3

REF.	DESCRIPTION (* indicates parts available in assemblies only)	PART #	QTY	
14	BLOCK, GUIDE (2)	536957-1	1	
15	CLAMP, 90-110 MM	F81095-8	1	
16	HOSE, MASTER CLIP PUR DN100 SAWDUST OUTLET (NUMBER OF COILS: 100)	546866	1	
17	BAR, MATERIAL GUIDE	561934-1	1	
18	SCREW, M8X60-8.8 DIN 7984 HEX SOCKET HEAD CAP	F81002-41	2	
19	SCREW, M8X16-8.8 FE/ZN5 DIN 7991 FLAT SOCKET HEAD CAP	F81002-115	2	
20	SCREW, M8X40-8.8 HEX SOCKET HEAD CAP ZINC	F81002-29	6	
21	WASHER, 8.4 FLAT ZINC	F81054-1	1	
22	SCREW, M8X90-8.8-FE/ZN5 ISO4762	F81002-44	1	
23	SHEAVE, MULTI-GROOVE SMALL	533586	1	
24	SCREW, M8X12-45H FE/ZN DIN914 HEX SOCKET SET W/CONE POINT	F81002-105	1	
25	CLAMP ROLLER ASSEMBLY <a href="#">See Section 3.14</a>	536980	2	
26	SCREW ASSEMBLY, TRAPEZOIDAL <a href="#">See Section 3.15</a>	541308	1	
27	BRUSH, H590 L=150	561873	1	
28	SCREW, M8X25-8.8 HEX SOCKET HEAD CAP ZINC	F81002-21	2	

**3.13 Left Spindle Assembly**

537005\_001\_EN  
 537005\_MANUAL

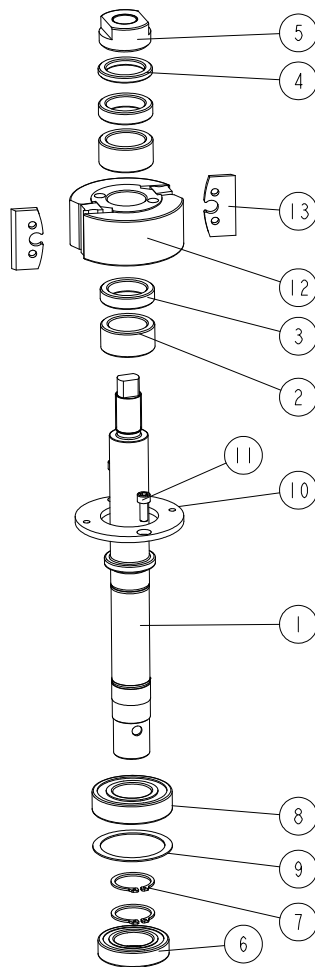

REF.	DESCRIPTION (◆ indicates parts available in assemblies only)	PART #	QTY
-	<b>SPINDLE ASSEMBLY, LEFT</b>	537005	1
1	SPINDLE	533537	1
2	BUSHING, 30/42-20.2 ZINC-PLATED	533541-1	2
3	BUSHING, 30/42-10 ZINC-PLATED	533539-1	2
4	BUSHING, 30/42-5.2 ZINC-PLATED	533540-1	1
5	NUT, M20X1.5 LEFT	533538-1	1
6	BEARING, 6006 DDUCM NSK	096191	1
7	RING, Z30 PN-M/85111 OUTSIDE RETAINING	F81090-23	2
8	BEARING, 6206 DDUCM NSK	100787	1
9	WASHER, 50X61.6X1 MP200	533543	1
10	PLATE, CLAMPING	533542-1	1
11	SCREW, M6X16-8.8 HEX SOCKET HEAD CAP ZINC	F81001-21	2
-	CUTTERHEAD, TB90-92 STEEL	240-010	1
12	CUTTERHEAD	533587	1
13	KNIFE, CUTTER	533588	2



### 3.14 Clamp Roller Assembly

536980\_001  
536980\_MANUAL

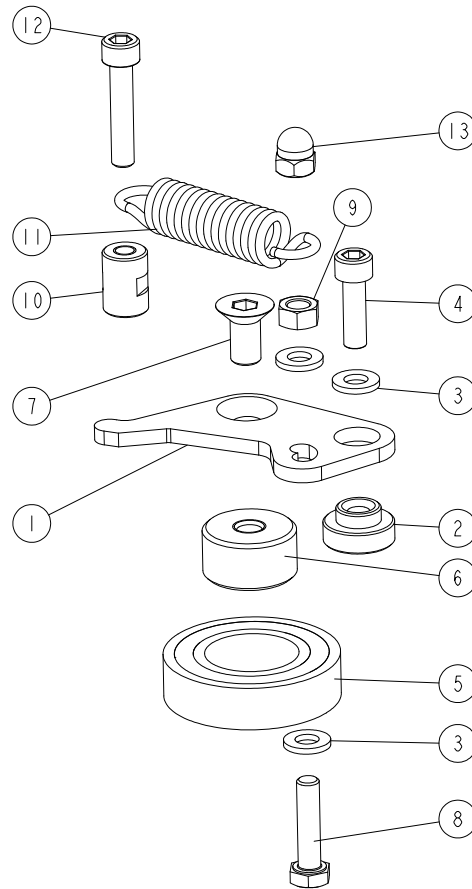

REF.	DESCRIPTION (◆ indicates parts available in assemblies only)	PART #	QTY
-	<b>ROLLER ASSEMBLY, MP360 CLAMP</b>	536980	1
1	BRACKET, BEARING MOVABLE	533525-1	1
2	BUSHING, 5.9/12-10 FLANGE 19-6	533632	1
3	WASHER, 6.4 FLAT ZINC	F81053-1	3
4	SCREW, M6X20-8.8 HEX SOCKET HEAD CAP ZINC	F81001-22	1
5	BEARING, 6005 2RS	089652	1
6	BUSHING, M8/25-13.5 ZINC-PLATED	533529-1	1
7	SCREW, M8X16 10.9 DIN7991 FLAT SOCKET HEAD CAP ZINC	F81002-82	1
8	BOLT, M6X25 -8.8 HEX HEAD FULL THREAD ZINC	F81001-3	1
9	NUT, M6-8 HEX ZINC	F81031-1	1
10	BUSHING, M6/12-17 ZINC-PLATED	533633-1	1
11	SPRING, 15X65X2.5 EXTENSION	533571	1
12	SCREW, M6X30-8.8 HEX SOCKET HEAD CAP ZINC	F81001-42	1
13	NUT, M6-6 DIN1587 ZINC-PLATED CAP	F81032-20	1

# 3 Mechanical Assembly, MP280 Planer/Moulder

## Trapezoidal Screw Assembly

### 3.15 Trapezoidal Screw Assembly

MP280EH13S-V\_026  
MP280EH13S-V

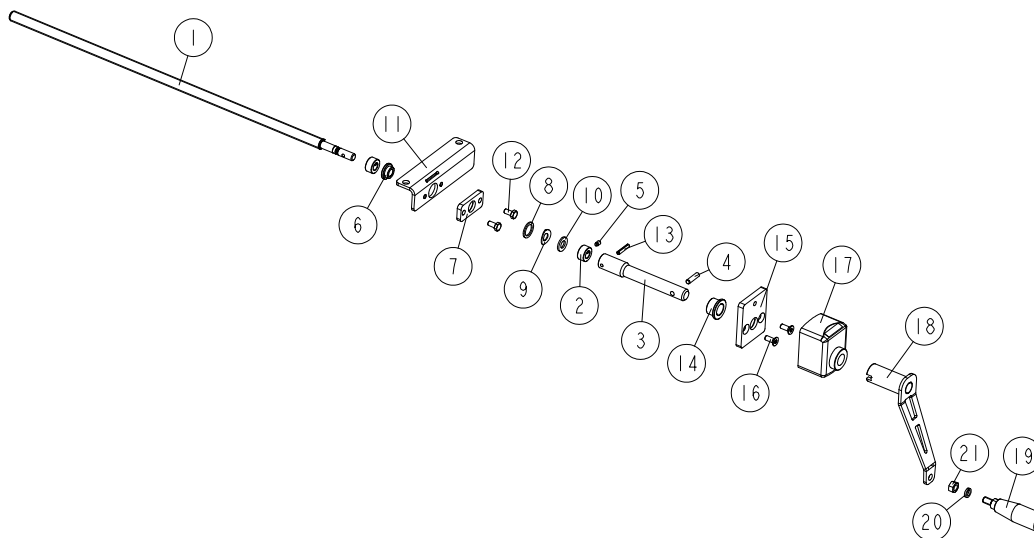

REF.	DESCRIPTION (* indicates parts available in assemblies only)	PART #	QTY
-	<b>SCREW ASSEMBLY, TRAPEZOIDAL</b>	541308	1
1	SCREW, TRAPEZOIDAL	535996	1
2	CONNECTOR (1)	535997-1	2
3	CONNECTOR (2)	561850-1	1
4	PIN, ISO2338-6M6X24-A1 DOWEL	F81045-5	1
5	SCREW, M5X8 45H FE/ZN DIN 915 HEX SOCKET SET W/DOG POINT	F81014-15	1
6	BUSHING, AMES TYPE B SELFOIL N10/N16/N22-8 /ALBECO SELF-LUBRICATING	541372	1
7	PLATE, SLIDE BUSHING	535991-1	1
8	SHIM, 16/22-1.5 DIN 988	F81055-19	1
9	WASHER, 10.5 DIN137 SPRING WAVE FORM B	F81055-18	1
10	WASHER, N10.5/N20-2	537967	1
11	PLATE, SCREW MOUNT	541290-1	1
12	BOLT, M6X12 8.8 HEX HEAD FULL THREAD ZINC	F81001-7	2
13	PIN, 4X24 ZINC-PLATED SPRING	F81044-13	1
14	BUSHING, AMES TYPE B SELFOIL N16/N22/N28-15/ALBECO/ SELF-LUBRICATING	541373	1
15	PLATE, POSITION INDICATOR MOUNT	561854-1	1
16	SCREW, M6X16-10.9 DIN7991 ISO10642 FLAT SOCKET HEAD CAP ZINC	F81001-55	2
17	INDICATOR, POSITION (METRIC)	536952	1
-	COMPLETE HANDLE	533669	1
18	HANDLE ASSEMBLY	533147-1	1
19	GRIP, CYLINDRICAL	533505	1
20	WASHER, 8.2 SPLIT LOCK ZINC	F81054-4	1
21	NUT, M8-8-B HEX ZINC	F81032-1	1

### 3.16 Up/Down Assembly

MP280EH13S-V\_027  
MP280EH13S-V

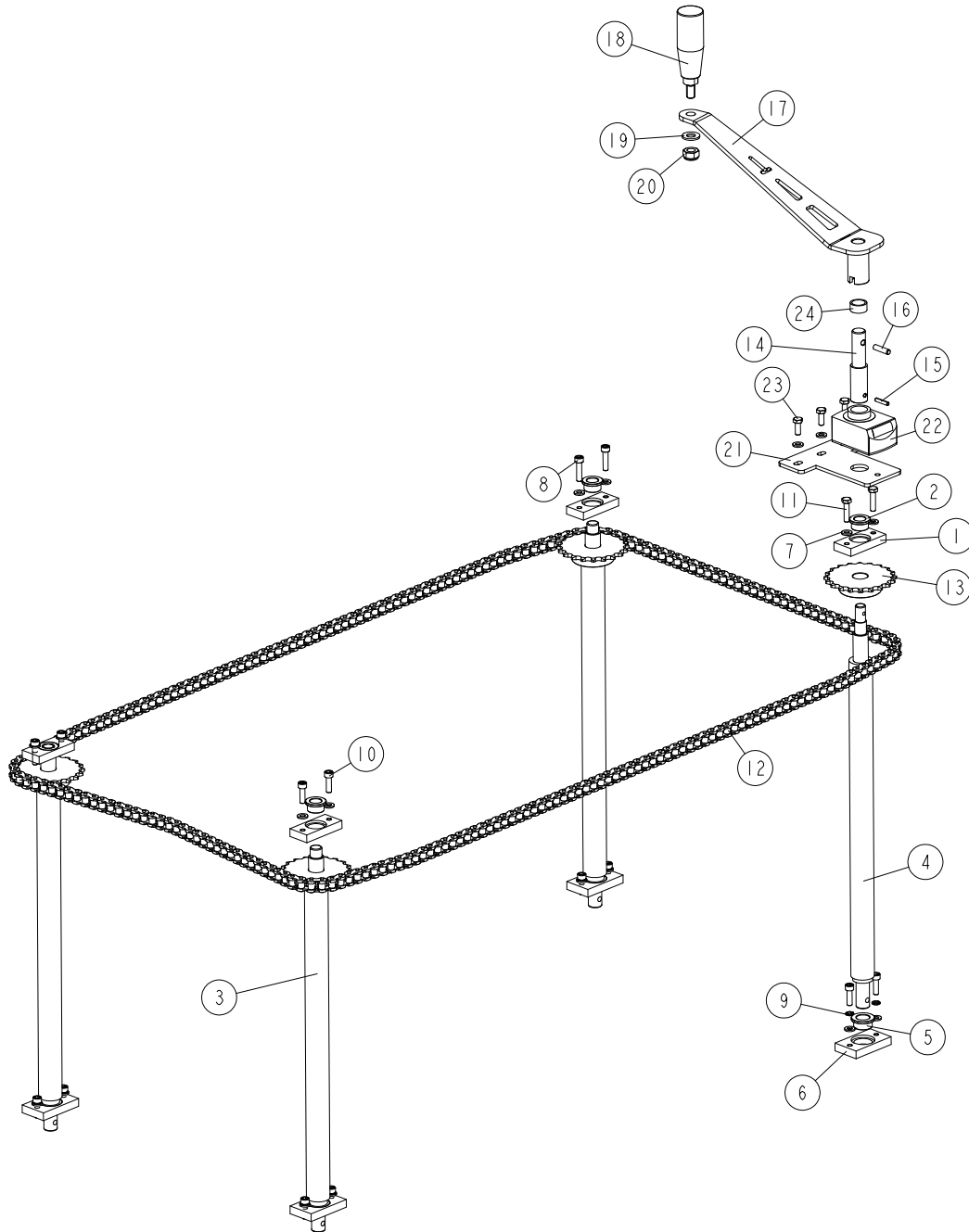

REF.	DESCRIPTION (* indicates parts available in assemblies only)	PART #	QTY
-	<b>UP/DOWN ASSEMBLY</b>	537252	1
1	BLOCK 2	561789-1	4
2	BUSHING, 14/20-9 FLANGE 25-3	537255	4
3	SCREW, TR28X5 TRAPEZOIDAL	537253	3
4	SCREW, TR28X5 LONG TRAPEZOIDAL	537254	1
5	BUSHING, 16/22-9 FLANGE 28-3	561788	4
6	BLOCK 1	537258-1	4

REF.	DESCRIPTION (* indicates parts available in assemblies only)	PART #	QTY
7	WASHER, 6.4 FLAT ZINC	F81053-1	19
8	SCREW, M6X25-8.8 HEX SOCKET HEAD CAP ZINC	F81001-41	3
9	WASHER, Z 6.1 SPLIT LOCK ZINC	F81053-3	8
10	SCREW, M6X20 8.8 HEX SOCKET HEAD CAP ZINC	F81001-22	11
11	BOLT, M6X25 -8.8 HEX HEAD FULL THREAD ZINC	F81001-3	2
12	CHAIN	541267	1
13	SPROCKET, Z=20 1/2"X 3/16" (CHAIN 083-1)	535832	4
14	PIN, POSITION INDICATOR MOUNT	561928-1	1
15	PIN, PN-EN ISO 8752-4X20-ST-A0P SPRING-TYPE	F81044-11	1
16	PIN, ISO2338- 6M6X24-A1 DOWEL	F81045-5	1
-	HANDLE ASSEMBLY	535975	1
17	HANDLE WELDMENT	535973-1	1
18	GRIP, CYLINDRICAL	535974	1
19	WASHER, 10.5 ZINC FLAT	F81055-1	1
20	NUT, M10-8-B HEX NYLON ZINC LOCK	F81033-1	1
21	PLATE, POSITION INDICATOR MOUNT	561931-1	1
22	INDICATOR, MP280 UP/DOWN POSITION	564936	1
23	BOLT, M6X16-8.8 HEX HEAD FULL THREAD ZINC	F81001-15	3
24	BUSHING, 16/20-9.5	564937	1

3.17 Chain Guides

MP280EH13S-V\_028  
MP280EH13S-V

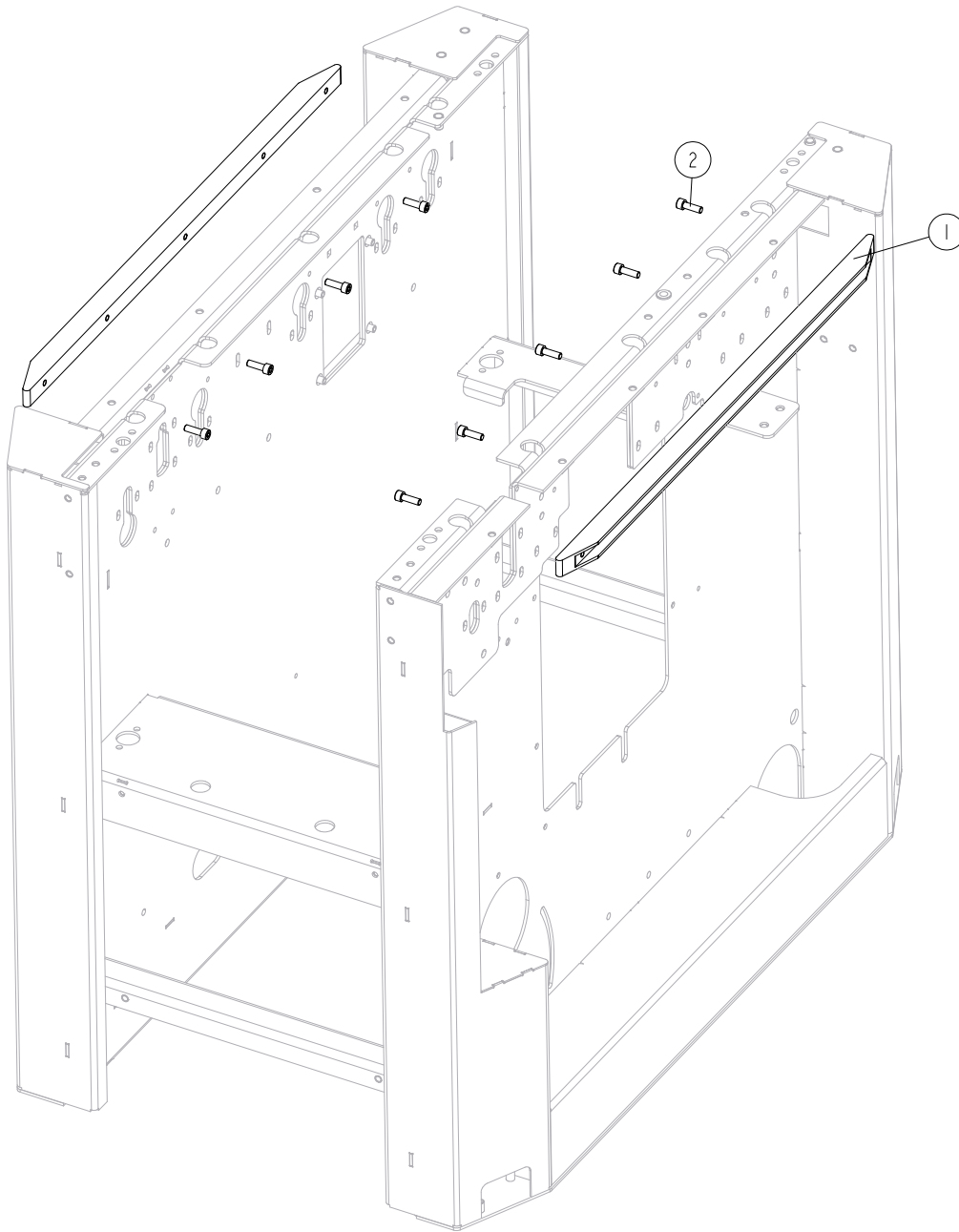

REF.	DESCRIPTION (* indicates parts available in assemblies only)	PART #	QTY
1	GUIDE, CHAIN (1)	561808	2
2	SCREW, M8X25-8.8 HEX SOCKET HEAD CAP ZINC	F81002-21	9

**3.18 Anti-Kickback Fingers**

MP280EH13S-V\_029  
 MP280EH13S-V

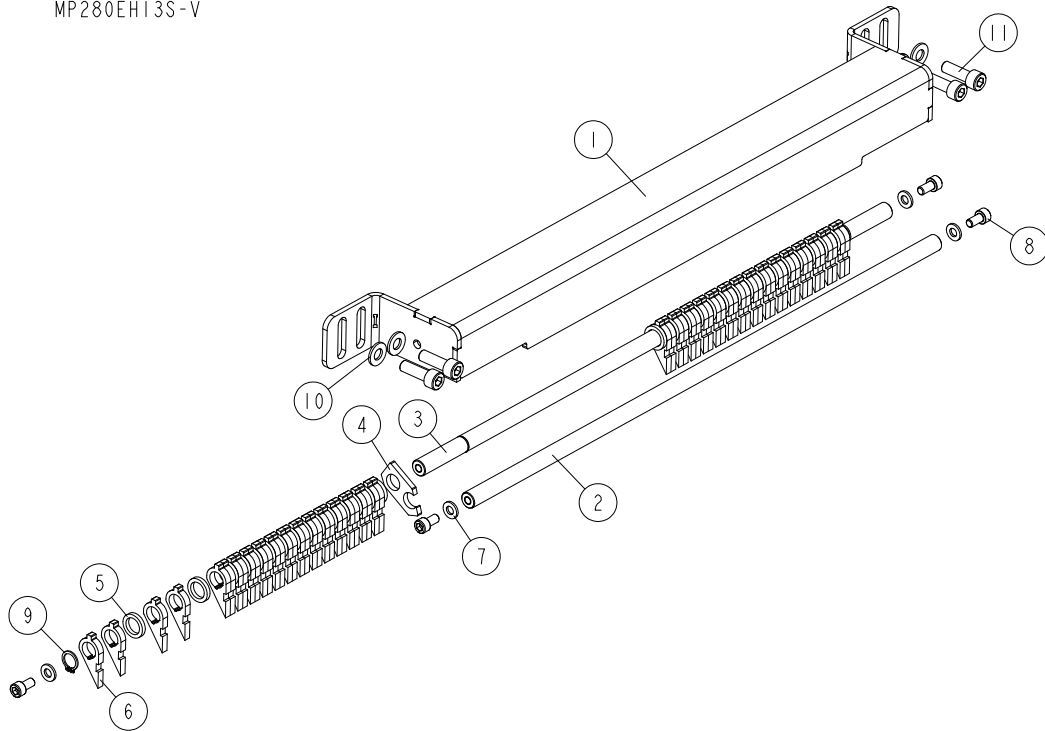

REF.	DESCRIPTION (* indicates parts available in assemblies only)	PART #	QTY
-	<b>FINGER SET, ANTI-KICKBACK</b>	561965	1
1	BRACKET	561963-1	1
-	<b>FINGER ASSEMBLY, ANTI-KICKBACK</b>	561982	1
2	SHAFT	533092-1	1
3	ROD, ANTI-KICKBACK FINGER	546931-1	1
4	PLATE	533124-1	1
5	WASHER, DIA.1940	533123	30
-	<b>FINGER, ANTI-KICKBACK COMPLETE</b>	533126	30
6	FINGER, ANTI-KICKBACK	133-045-1	2
7	WASHER, 6.4 FLAT ZINC	F81053-1	4
8	SCREW, M6X12-8.8-A2E ISO 4762 HEX SOCKET HEAD CAP	F81001-87	4
9	RING, Z 12 OUTSIDE RETAINING	F81090-14	2
10	WASHER, 8.4 FLAT ZINC	F81054-1	4
11	SCREW, M8X25-8.8 HEX SOCKET HEAD CAP ZINC	F81002-21	4

3.19 Table

MP280EH13S-V\_035  
MP280EH13S-V

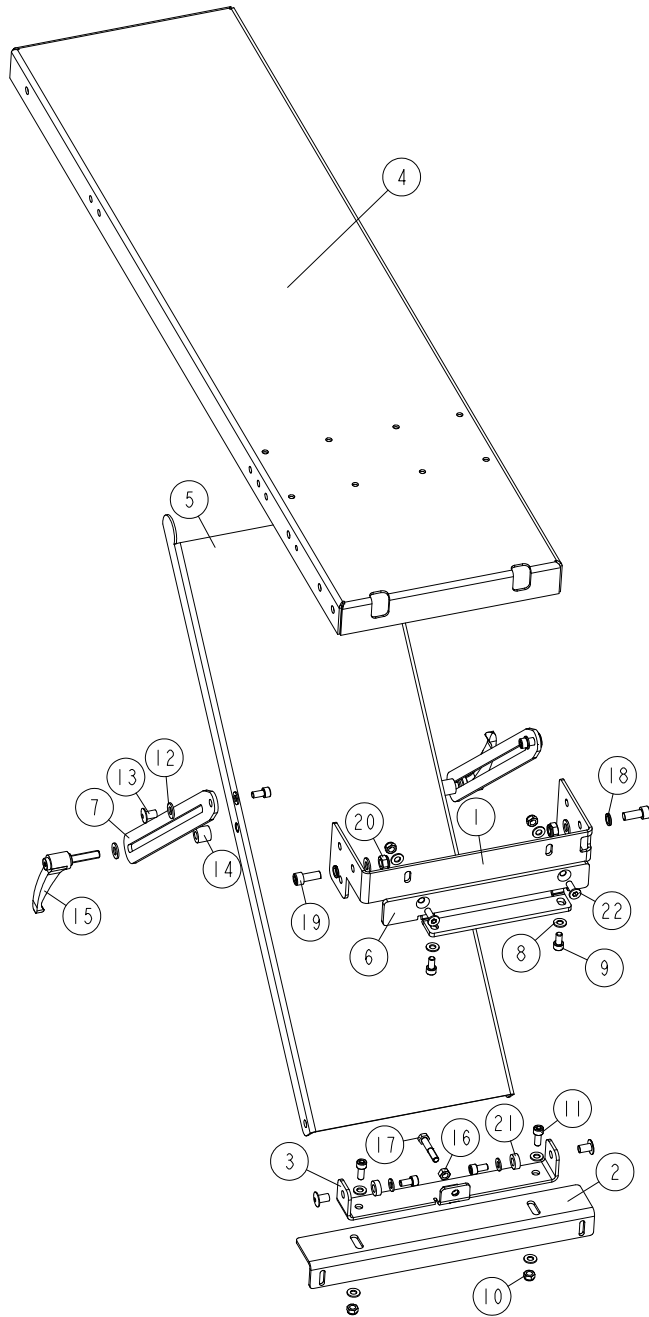

REF.	DESCRIPTION (* indicates parts available in assemblies only)	PART #	QTY
-	TABLE, MP280	546941	1
1	BRACKET	541219-1	1
2	ANGLE	265-104-1	1
3	BRACKET WELDMENT	541453-1	1
4	PLATE, MP280 TABLE	541260-1	1
5	PLATE, MP280 SUPPORT - COMPLETE	541251-1	1
6	BRACKET	561872-1	1
7	PLATE W/SLOTTED HOLE	541248-1	2

REF.	DESCRIPTION (* indicates parts available in assemblies only)	PART #	QTY	
8	WASHER, 8.4 FLAT ZINC	F81054-1	12	
9	SCREW, M8X16-8.8 HEX SOCKET HEAD CAP ZINC	F81002-39	6	
10	NUT, M8-8-B HEX NYLON ZINC LOCK	F81032-2	4	
11	SCREW, M8X20-8.8 HEX SOCKET HEAD CAP ZINC	F81002-30	2	
12	WASHER, 10.5 ZINC FLAT	F81055-1	6	
13	NUT, ERICSON M8 AN88 COLLAR ZINC	F81032-33	4	
14	BUSHING, 10.2/20-18 SPACER	541249	2	
15	LEVER, ERZ.78 P-M10X40 ADJUSTABLE	533536	2	
16	NUT, M8-8-B HEX ZINC	F81032-1	1	
17	BOLT, M8X45-8.8 HEX HEAD ZINC	F81002-17	1	
18	WASHER, Z 10.2 SPLIT LOCK ZINC	F81055-2	2	
19	SCREW, M10X25 8.8 HEX SOCKET HEAD CAP ZINC	F81003-32	2	
20	NUT, M10-8-B HEX NYLON ZINC LOCK	F81033-1	2	
21	BUSHING, 10.2/20-7 SPACER	546939	2	
22	SCREW, M8X25-8.8 DIN 7991FLAT SOCKET HEAD CAP ZINC	F81002-65	2	



## 3.20 Clamp Roller Assembly (No. 533550)

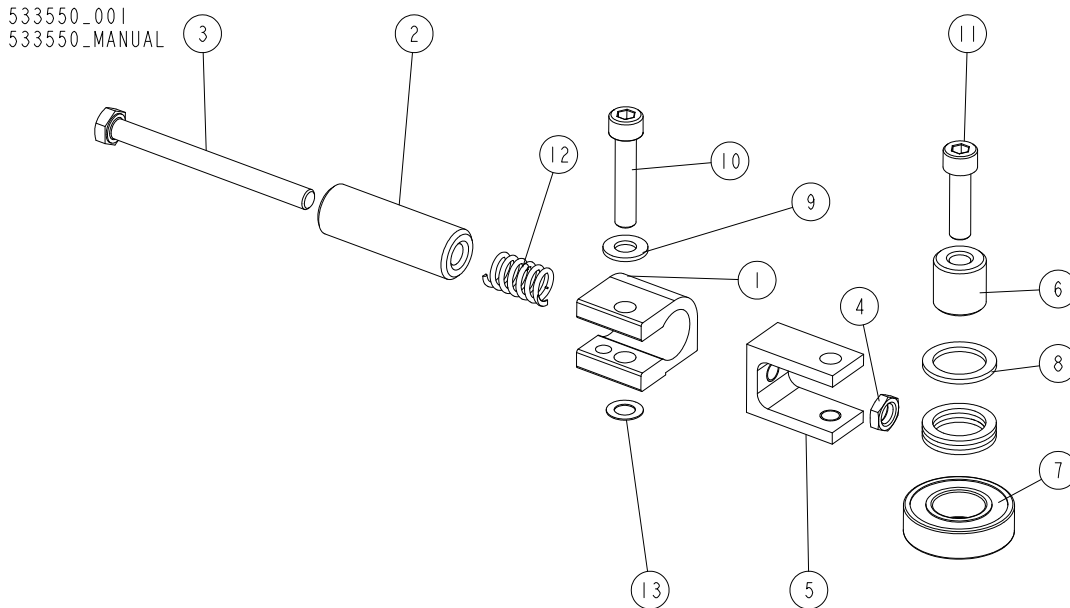

REF.	DESCRIPTION (* indicates parts available in assemblies only)	PART #	QTY
-	<b>CLAMP ROLLER ASSEMBLY II</b>	533550	1
1	CONNECTOR, ALUMINIUM	533551-1	1
2	BUSHING, 8.5/20-60 ZINC-PLATED	533553-1	1
3	BOLT, M8X90-8.8 HEX HEAD FULL THREAD ZINC	F81002-16	1
4	NUT, M8-04-HEX THIN ZINC	F81032-8	1
5	CONNECTOR, ALUMINIUM	533552	1
6	BUSHING, 8.2/20-20	533554-1	1
7	BEARING, 6004 2RS CX ROLLING	093868	1
8	WASHER, 28/20-2	533555	4
9	WASHER, 8.4 FLAT ZINC	F81054-1	1
10	SCREW, M8X40-8.8 HEX SOCKET HEAD CAP ZINC	F81002-29	1
11	SCREW, M8X30-8.8 HEX SOCKET HEAD CAP ZINC	F81002-31	1
12	SPRING, 12X25XN2	533556	1
13	WASHER, 14/8-0.5 DIN 988 SPACER	F81055-16	1

## SECTION 4 GUARDS &amp; COVERS

## 4.1 Right Cover

MP280EH13S-V\_013  
MP280EH13S-V

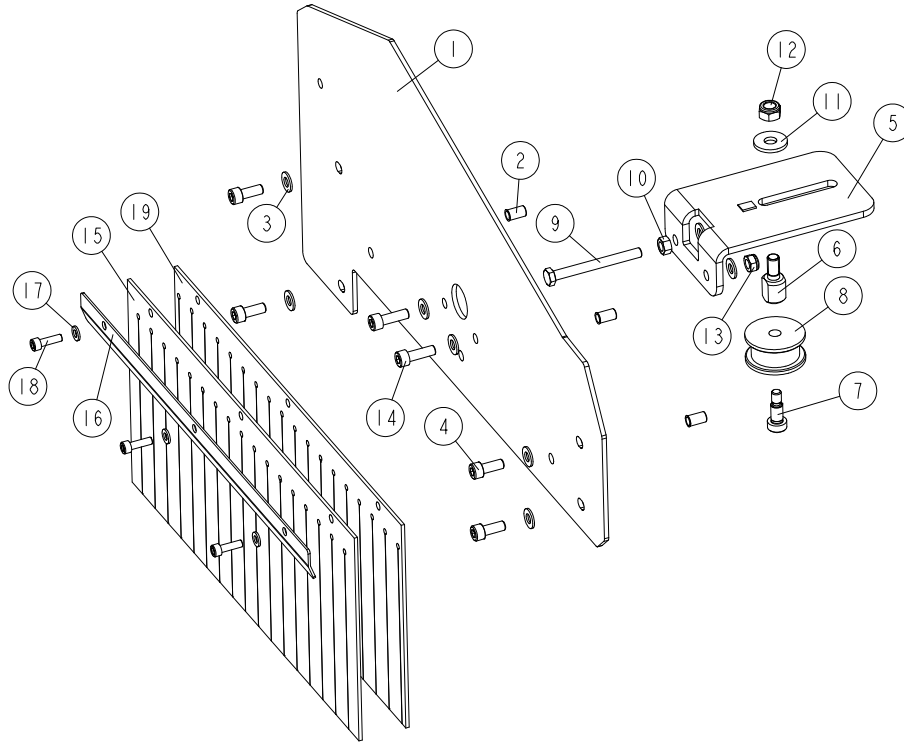

REF.	DESCRIPTION (* indicates parts available in assemblies only)	PART #	QTY
-	<b>COVER, RIGHT - COMPLETE</b>	546918	1
1	PLATE, LEFT COVER	541178-1	1
2	NUT, M6 1.5-4.0 MIN MTRG ZINC STEEL RIVET	F81031-13	3
3	WASHER, 8.4 FLAT ZINC	F81054-1	8
4	SCREW, M8X20-8.8 HEX SOCKET HEAD CAP ZINC	F81002-30	4
5	PLATE WELDMENT, TENSION	561812-1	1
6	BOLT, MOUNTING	534388-1	1
7	BOLT, ISO 7379-10-M8-16 12.9 SHOULDER	F81003-139	1
8	ROLLER, TENSIONER	533576	1
9	BOLT, M8X80-8.8 HEX HEAD FULL THREAD ZINC	F81002-99	1
10	NUT, M8-8-B HEX ZINC	F81032-1	1
11	WASHER, 10.5 SPECIAL FLAT ZINC	F81055-6	1
12	NUT, M10-8-B HEX NYLON ZINC LOCK	F81033-1	1
13	NUT, M8-8-B HEX NYLON ZINC LOCK	F81032-2	2
14	SCREW, M8X25-8.8 HEX SOCKET HEAD CAP ZINC	F81002-21	2
-	GUARD, COMPLETE FLEXIBLE	533729	1
15	GUARD, FLEXIBLE	533083	1
16	BRACKET, FLEXIBLE GUARD	533082-1	1
17	WASHER, 6.4 FLAT ZINC	F81053-1	3
18	SCREW, M6X20 8.8 HEX SOCKET HEAD CAP ZINC	F81001-22	3

---

REF.	DESCRIPTION (* indicates parts available in assemblies only)	PART #	QTY	
19	GUARD, FLEXIBLE	564886	1	

## 4.2 Top Cover

MP280EH13S-V\_014  
MP280EH13S-V

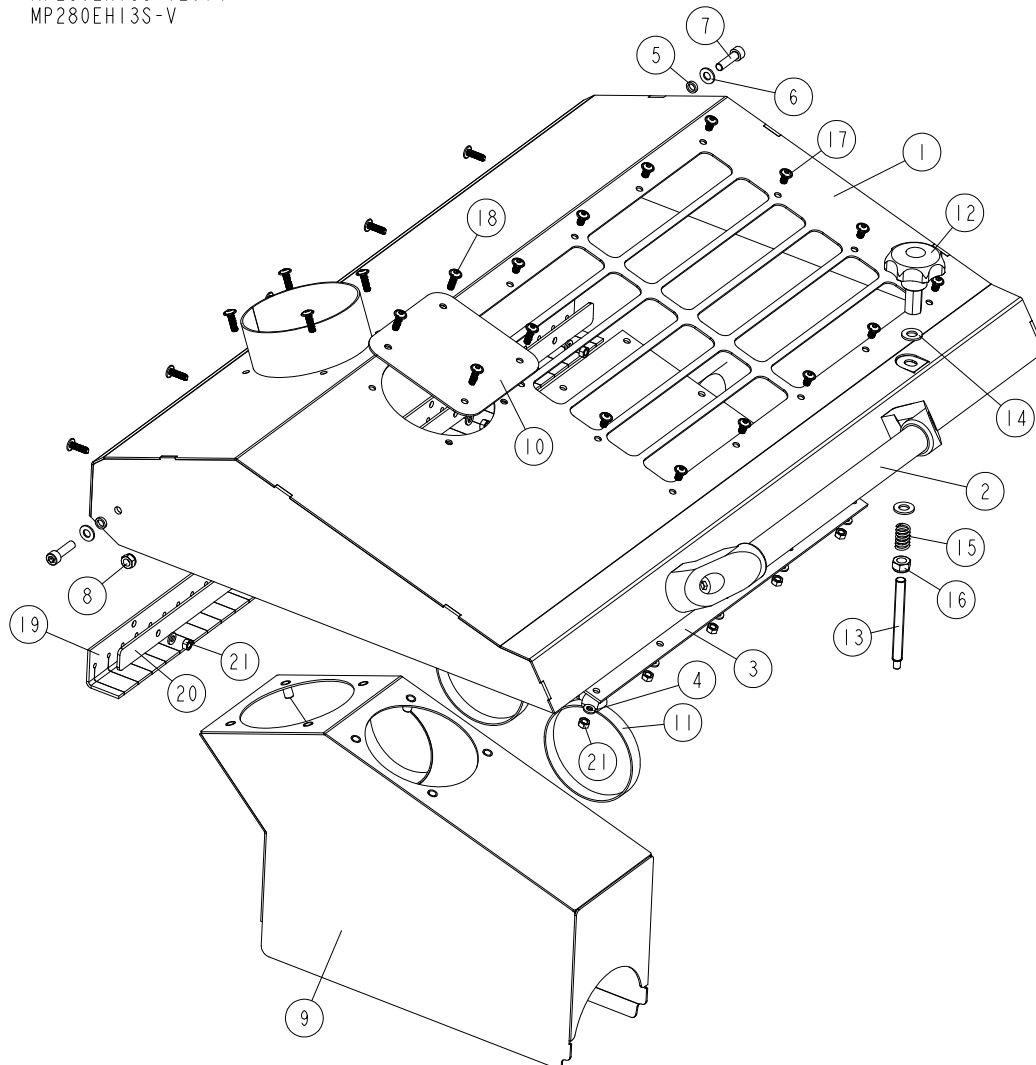

REF.	DESCRIPTION (* indicates parts available in assemblies only)	PART #	QTY
-	COVER WELDMENT, TOP	541161	1
1	COVER WELDMENT	541162-1	1
2	HANDLE	535614	1
3	PLATE, INSPECTION WINDOW	541171	1
4	WASHER, 6.4 FLAT ZINC	F81053-1	19
5	BUSHING, SPACER	533674	2
6	WASHER, 8.4 FLAT ZINC	F81054-1	2
7	SCREW, M8X30-8.8 HEX SOCKET HEAD CAP ZINC	F81002-31	2
8	NUT, M8-8-B HEX NYLON ZINC LOCK	F81032-2	2
9	OUTLET WELDMENT, ZINC-PLATED SAWDUST	541302-1	1
10	CAP	535609-1	1
11	CLAMP, 90-110 MM	F81095-8	2
-	KNOB ASSEMBLY, STAR	546845	1
12	KNOB, GW M10 STAR	562020	1
13	ROD, M10X100 THREADED	546843	1

REF.	DESCRIPTION (* indicates parts available in assemblies only)	PART #	QTY	
14	WASHER, 10.5 ZINC FLAT	F81055-1	2	
15	SPRING	533677	1	
16	NUT, M10-8-B HEX NYLON ZINC LOCK	F81033-1	1	
17	SCREW, M6X12 ISO 7380-2 A2 ZINC-PLATED BUTTON HEAD	F81000-104	14	
18	SCREW, M6X20 ISO 7380-2 A2 ZINC-PLATED BUTTON HEAD	F81000-106	13	
19	GUARD, FLEXIBLE	561992	1	
20	BAR, CLAMPING	562018-1	1	
21	NUT, M6 8 HEX ZINC	F81031-1	19	

# 4 GUARDS & COVERS

## Right Cover

### 4.3 Right Cover

MP280EH13S-V\_015  
MP280EH13S-V

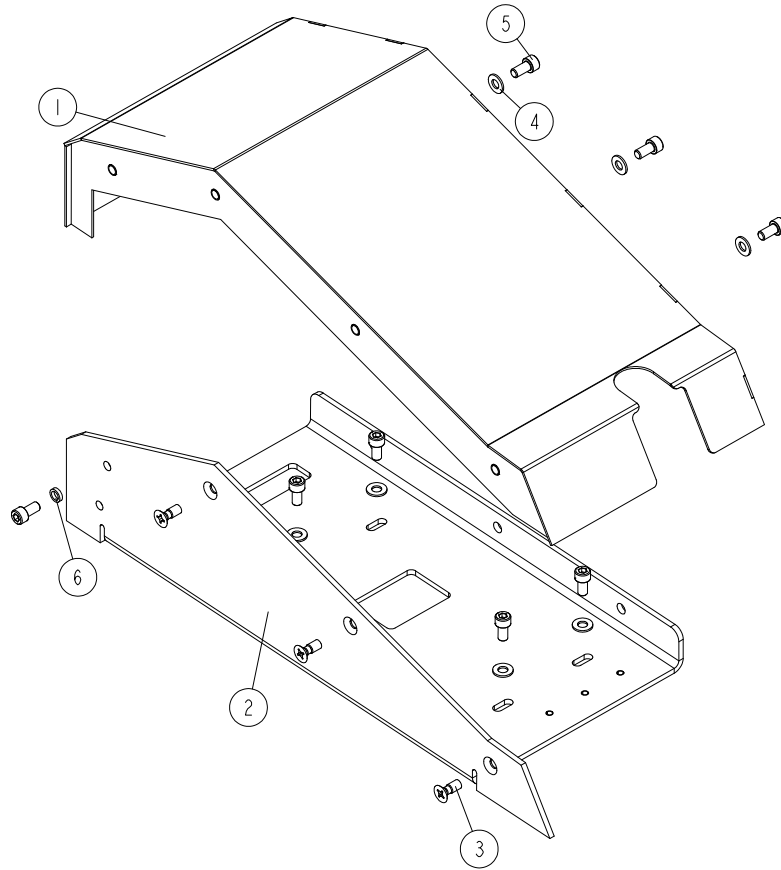

REF.	DESCRIPTION (* indicates parts available in assemblies only)	PART #	QTY
-	<b>COVER, COMPLETE RIGHT</b>	561921	1
1	COVER WELDMENT, RIGHT	561922-1	1
2	PLATE ASSEMBLY, RIGHT COVER	561927-1	1
3	SCREW, M8X20-5.8 CROSS RECESSED FLAT HEAD ZINC	F81002-94	3
4	WASHER, 8.4 FLAT ZINC	F81054-1	7
5	SCREW, M8X16-8.8 HEX SOCKET HEAD CAP ZINC	F81002-39	8
6	BUSHING, SPACER	533674	1

## 4.4 Front Cover

MP280EH13S-V\_016  
 MP280EH13S-V

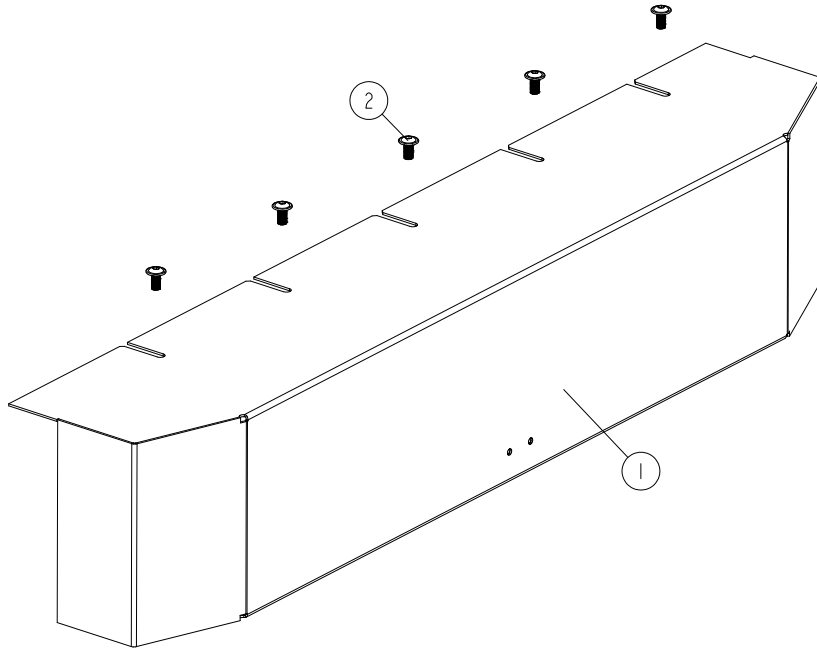

REF.	DESCRIPTION (* indicates parts available in assemblies only)	PART #	QTY	
1	COVER WELDMENT, FRONT	561987-1	1	
2	SCREW, M8X16 ISO 7380-2 A2 ZINC-PLATED BUTTON HEAD	F81000-103	5	

## 4.5 Moving Spindle Guard

MP280EH13S-V\_017  
MP280EH13S-V

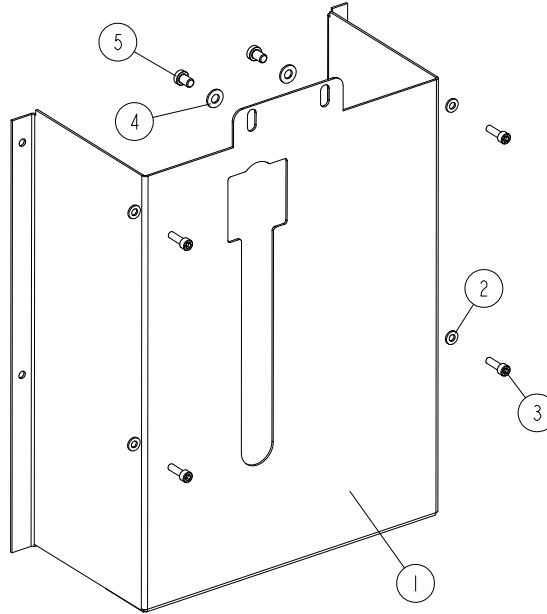

REF.	DESCRIPTION (* indicates parts available in assemblies only)	PART #	QTY
1	PLATE, GUARD (1)	541190-1	1
2	WASHER, 6.4 FLAT ZINC	F81053-1	4
3	SCREW, M6X20 8.8 HEX SOCKET HEAD CAP ZINC	F81001-22	4
4	WASHER, 8.4 FLAT ZINC	F81054-1	2
5	SCREW, M8X12 10.9 HEX SOCKET THIN HEAD CAP	F81002-110	2



## 4.6 Front Guard

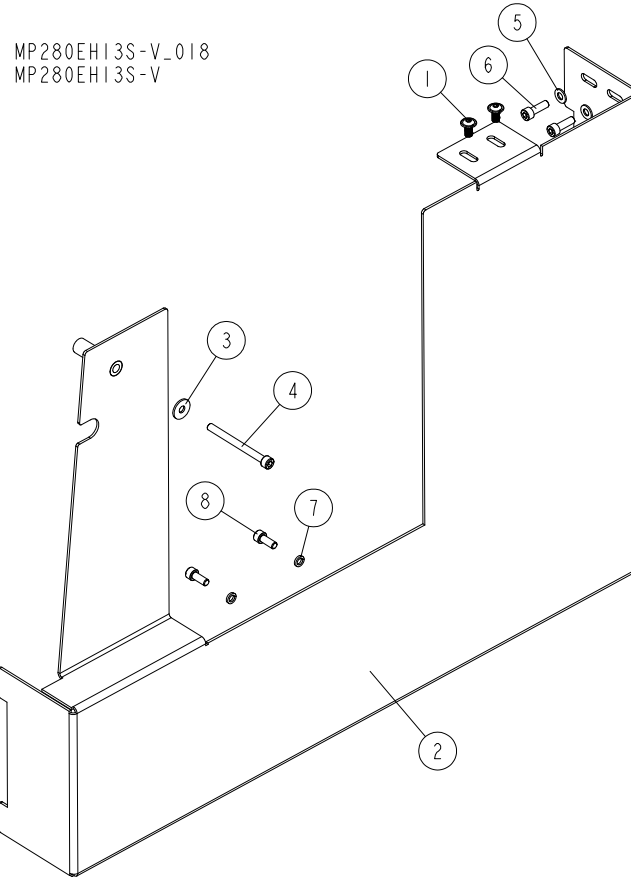

REF.	DESCRIPTION (* indicates parts available in assemblies only)	PART #	QTY	
1	SCREW, M8x16 ISO 7380-2 A2 ZINC-PLATED BUTTON HEAD	F81000-103	2	
2	<b>GUARD WELDMENT, FRONT</b>	561972-1	1	
3	WASHER, ISO 7093-1-8-200 HV-A2E	F81054-11	1	
4	SCREW, M8X75-8.8-FE/ZN5 ISO4762 HEX SOCKET HEAD CAP ZINC	F81002-162	1	
5	WASHER, 8.4 FLAT ZINC	F81054-1	2	
6	SCREW, M8X25-8.8 HEX SOCKET HEAD CAP ZINC	F81002-21	2	
7	WASHER, 8.2 SPLIT LOCK ZINC	F81054-4	3	
8	SCREW, M8X20-8.8 HEX SOCKET HEAD CAP ZINC	F81002-30	3	

**4.7 Rear Guard**

MP280EH13S-V\_019  
MP280EH13S-V

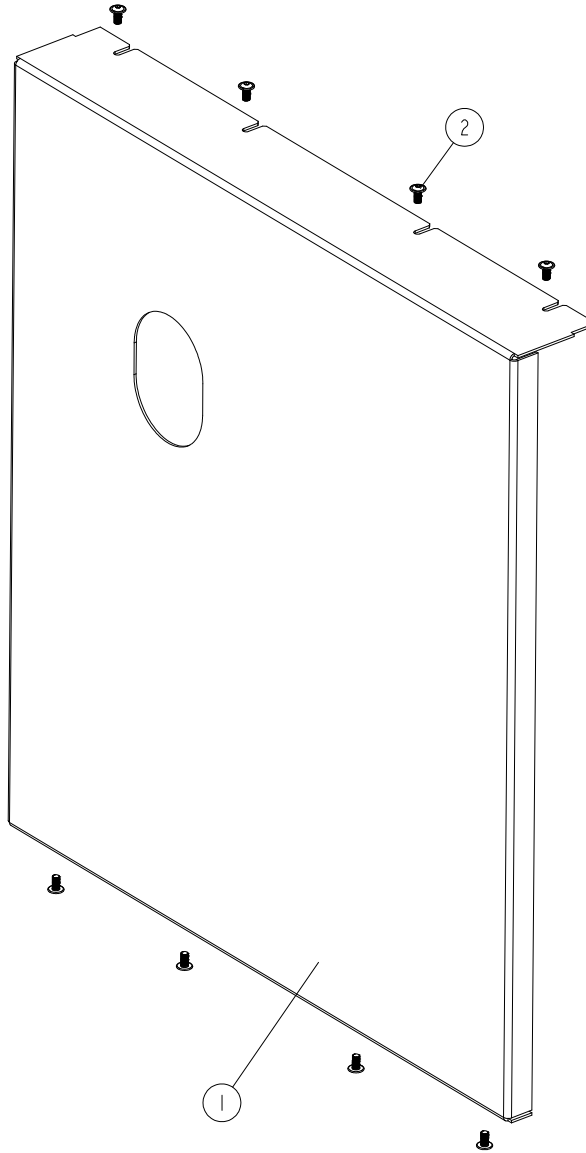

REF.	DESCRIPTION (* indicates parts available in assemblies only)	PART #	QTY	
1	GUARD ASSEMBLY, REAR	561916-1	1	
2	SCREW, M8X16 ISO 7380-2 A2 ZINC-PLATED BUTTON HEAD	F81000-103	8	

**4.8 Sawdust Outlet**

MP280EH13S-V\_020  
MP280EH13S-V

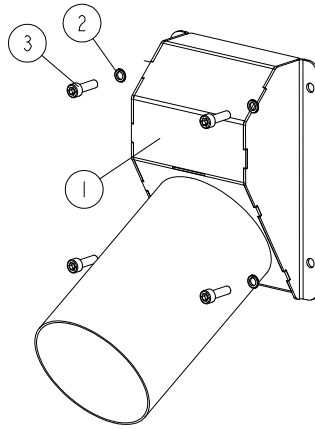

REF.	DESCRIPTION (* indicates parts available in assemblies only)	PART #	QTY	
1	OUTLET, SAWDUST	541124-1	1	
2	WASHER, Z 6.1 SPLIT LOCK ZINC	F81053-3	4	
3	SCREW, M6X20 8.8 HEX SOCKET HEAD CAP ZINC	F81001-22	4	

**4.9 Chain Guard**

MP280EH13S-V\_021  
MP280EH13S-V

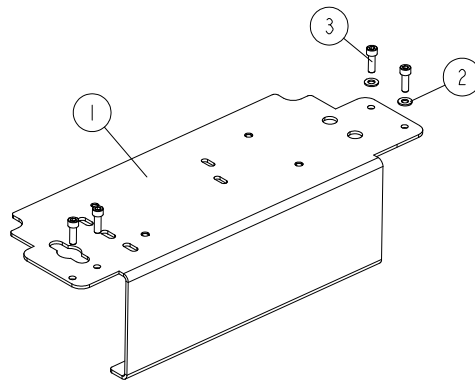
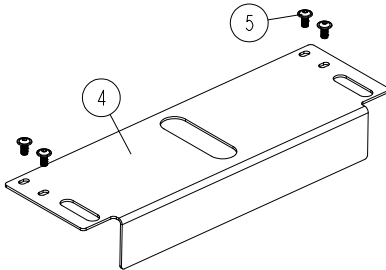

REF.	DESCRIPTION (* indicates parts available in assemblies only)	PART #	QTY
-	<b>GUARD ASSEMBLY, INFEEED</b>	541186	1
1	GUARD WELDMENT	561929-1	1
2	WASHER, 8.4 FLAT ZINC	F81054-1	2
3	SCREW, M8X25-8.8 HEX SOCKET HEAD CAP ZINC	F81002-21	4
4	<b>GUARD, CHAIN</b>	561915-1	1
5	SCREW, M8X16 ISO 7380-2 A2 ZINC-PLATED BUTTON HEAD	F81000-103	4

## SECTION 5 MOTORS

### 5.1 Motor Set, MP280EH 3x400V CE

MP280EH13S-V\_030  
MP280EH13S-V

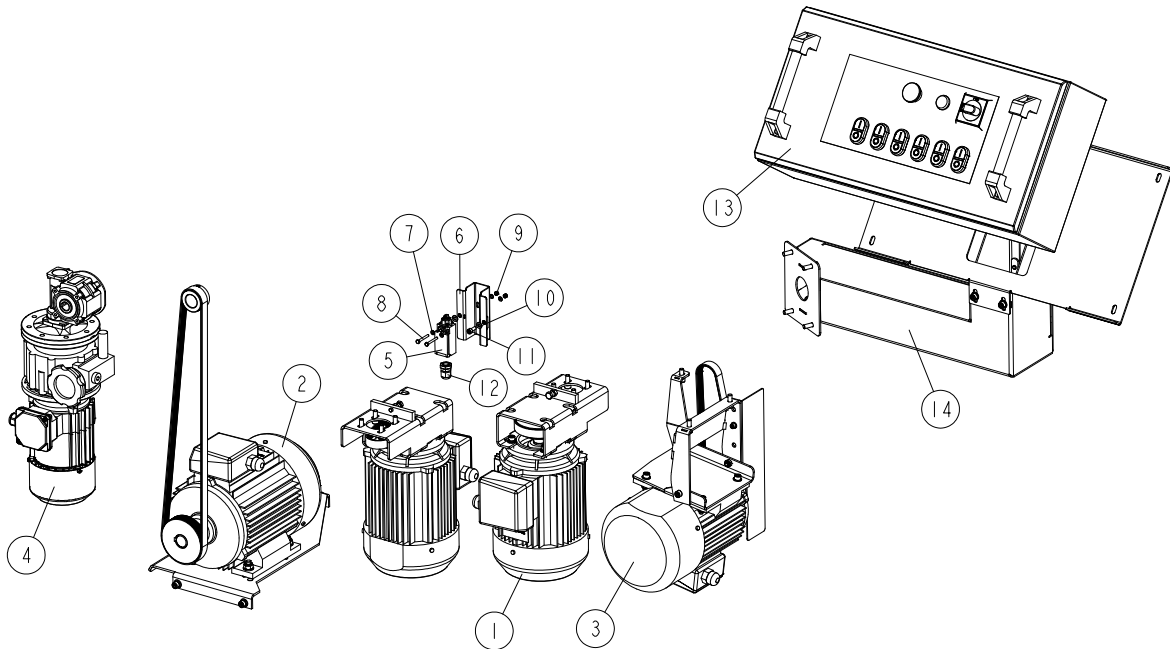

REF.	DESCRIPTION (* indicates parts available in assemblies only)	PART #	QTY
-	<b>MOTOR SET, PRO MP280EH 3x400V CE</b>	541139	1
1	DRIVE, SPINDLE <a href="#">See Section 5.2</a>	533647	2
2	DRIVE, PRO UPPER CUTTER <a href="#">See Section 5.3</a>	546959	1
3	DRIVE, LOWER CUTTER <a href="#">See Section 5.4</a>	541222	1
4	DRIVE, PRO MP280 FEED <a href="#">See Section 5.5</a>	546957	1
-	SWITCH ASSEMBLY, LIMIT	546909	1
5	SWITCH, D4N-4132 LIMIT	537641	1
6	GUARD, LIMIT SWITCH	546910-1	1
7	WASHER, 4.3 FLAT ZINC	F81051-2	4
8	BOLT, M4X35-8.8 DIN933 HEX HEAD FULL THREAD ZINC	F81011-7	2
9	NUT, M4-8 HEX NYLON ZINC LOCK	F81029-1	2
10	WASHER, 6.4 FLAT ZINC	F81053-1	2
11	SCREW, M6X16 8.8 HEX SOCKET HEAD CAP ZINC	F81001-21	2
12	GLAND, DP9/H CABLE	F81096-2	1
13	BOX, MP280H ELECTRICAL - COMPLETE <a href="#">See Section 5.7</a>	546916	1
14	BRACKET, ELECTRICAL BOX MOUNT - COMPLETE <a href="#">See Section 5.6</a>	561935	1

## 5.2 Spindle Drive Assembly

533647\_001\_B  
533647\_MANUAL

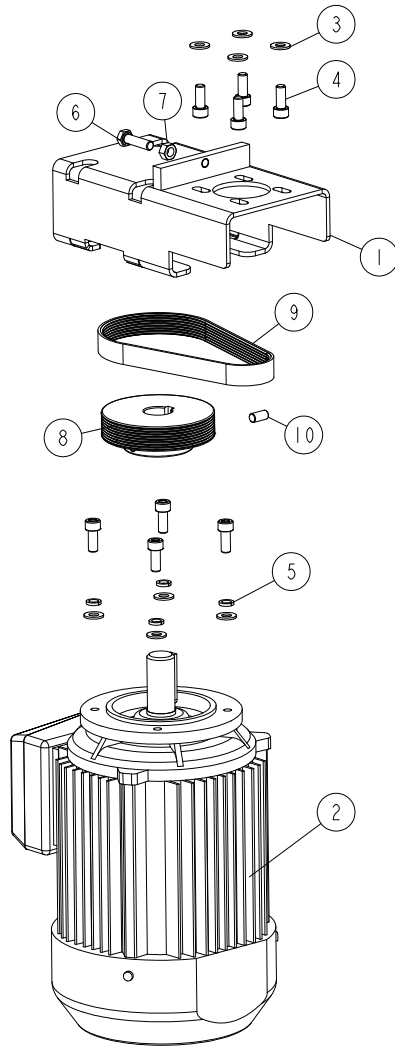

REF.	DESCRIPTION (◆ indicates parts available in assemblies only)	PART #	QTY
-	<b>DRIVE ASSEMBLY, MP200/MP360 SPINDLE</b>	533647	1
1	BRACKET WELDMENT, MOTOR MOUNT	533649-1	1
2	MOTOR, INDUKTA 3SIEK90L2A 3KW IMV19 UL	537385	1
3	WASHER, 8.4 FLAT ZINC	F81054-1	8
4	SCREW, M8X20-8.8 HEX SOCKET HEAD CAP ZINC	F81002-30	8
5	WASHER, 8.2 SPLIT LOCK ZINC	F81054-4	4
6	BOLT, M8X30-8.8-B HEX HEAD FULL THREAD ZINC	F81002-7	1
7	NUT, M8-8-B HEX ZINC	F81032-1	1
8	SHEAVE, MULTI-GROOVE ALUMINIUM	533585	1
9	SCREW, M8X16-45H FE/ZN DIN 913 HEX SOCKET SET W/FLAT POINT	F81002-124	1
10	BELT, 8 PJ 457 CONTITECH MULTI-RIBBED	533680	1

### 5.3 Upper Cutter Drive Assembly

MP280EH13S-V\_032  
MP280EH13S-V

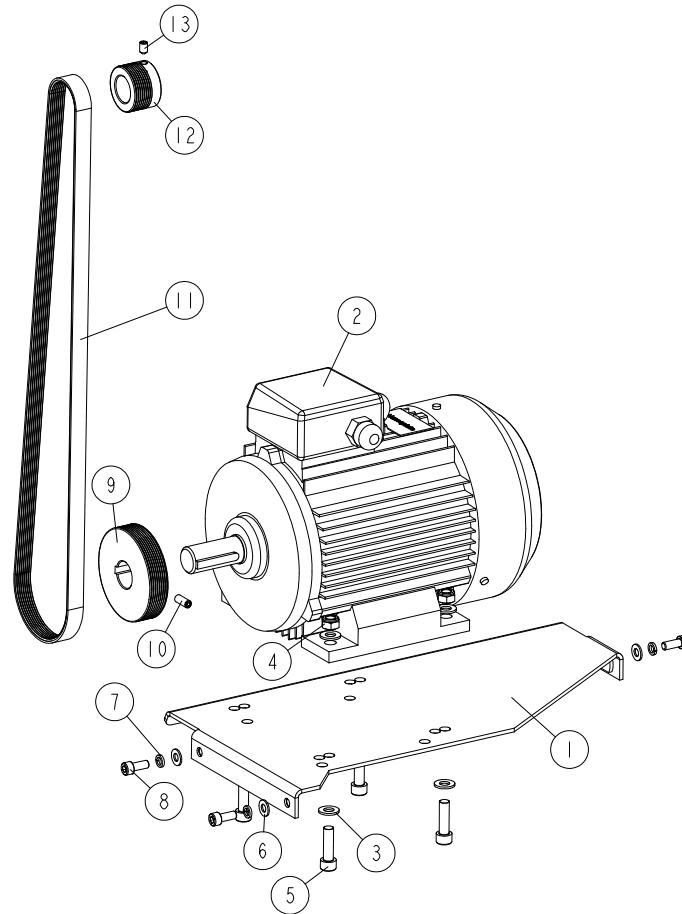

REF.	DESCRIPTION (* indicates parts available in assemblies only)	PART #	QTY
-	<b>DRIVE ASSEMBLY, PRO UPPER CUTTER</b>	546959	1
1	PLATE WELDMENT, MOTOR MOUNT	546425-1	1
2	MOTOR, 3SIE100L2A 4KW 2900 R.P.M. 50HZ	537387	1
3	WASHER, 10.5 ZINC FLAT	F81055-1	8
4	NUT, M10-8-B HEX NYLON ZINC LOCK	F81033-1	4
5	SCREW, M10X35-8.8 HEX SOCKET HEAD CAP ZINC	F81003-56	4
6	WASHER, 8.4 FLAT ZINC	F81054-1	3
7	WASHER, 8.2 SPLIT LOCK ZINC	F81054-4	3
8	SCREW, M8X20-8.8 HEX SOCKET HEAD CAP ZINC	F81002-30	3
9	SHEAVE, MP200 PRO MULTI-GROOVE	533585-P	1
10	SCREW, M8X20-45H GEOMET HEX SOCKET SET W/FLAT POINT	F81002-103	1
11	BELT, PJ8 1333 MULTI-RIBBED	537022	1
12	SHEAVE, MULTI-GROOVE SMALL	533586	1
13	SCREW, M8X12-45H FE/ZN DIN914 HEX SOCKET SET W/CONE POINT	F81002-105	1

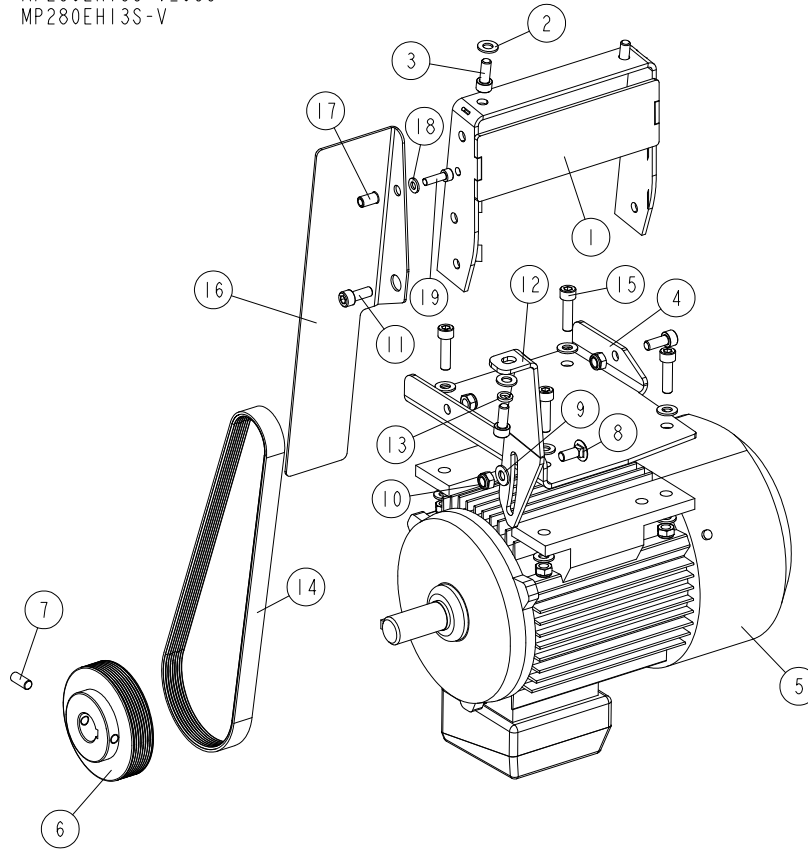
**5.4 Lower Cutter Drive Assembly**MP280EH13S-V\_033  
MP280EH13S-V

REF.	DESCRIPTION (* indicates parts available in assemblies only)	PART #	QTY
-	<b>DRIVE ASSEMBLY, LOWER CUTTER</b>	541222	1
-	BRACKET, MOTOR - COMPLETE	541225	1
1	BRACKET WELDMENT, MOTOR	541226-1	1
2	WASHER, 8.4 FLAT ZINC	F81054-1	2
3	SCREW, M8X20-8.8 HEX SOCKET HEAD CAP ZINC	F81002-30	2
4	PLATE, MOTOR MOUNT	541223-1	1
5	MOTOR, 3SIE90L2A 3KW 2900 R.P.M. 50HZ	537386	1
6	SHEAVE, MULTI-GROOVE	533585	1
7	SCREW, M8X20-45H GEOMET HEX SOCKET SET W/FLAT POINT	F81002-103	1
8	BOLT, M8X20-8.8 CARRIAGE ZINC	F81002-11	1
9	WASHER, 8.4 FLAT ZINC	F81054-1	10
10	NUT, M8-8-B HEX NYLON ZINC LOCK	F81032-2	7
11	SCREW, M8X20-8.8 HEX SOCKET HEAD CAP ZINC	F81002-30	3
12	BRACKET	537024-1	1
13	WASHER, 8.2 SPLIT LOCK ZINC	F81054-4	1
14	BELT, 8 PJ762 MULTI-RIBBED	535803	1
15	SCREW, M8X30-8.8 HEX SOCKET HEAD CAP ZINC	F81002-31	4
-	GUARD, BELT - COMPLETE	541235	1
16	PLATE, BELT GUARD	541234-1	1
17	NUT, M6 1.5-4.0 MIN MTRG ZINC STEEL RIVET	F81031-13	1
18	WASHER, 6.4 FLAT ZINC	F81053-1	1
19	SCREW, M6X20 8.8 HEX SOCKET HEAD CAP ZINC	F81001-22	1



## 5.5 Feed Drive Assembly

MP280EH13S-V\_031  
MP280EH13S-V

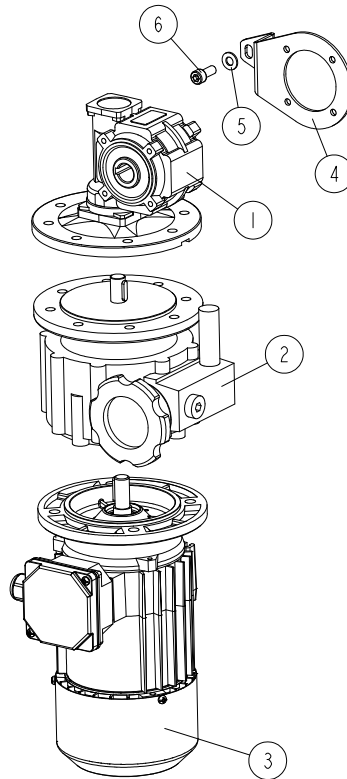

REF.	DESCRIPTION (* indicates parts available in assemblies only)	PART #	QTY
-	<b>DRIVE ASSEMBLY, PRO MP280 FEED</b>	546957	1
1	REDUCER, KC40/P15 160/14 V6 H18	535749	1
2	CONTINUOUSLY VARIABLE TRANSMISSION, NF005 160/14 B5 V3	535748	1
3	MOTOR, 3SIEK71X-2C/X 0.75KW 2780/3340 R.P.M.	535747	1
4	ARM, TORQUE	561804-1	1
5	WASHER, 8.4 FLAT ZINC	F81054-1	1
6	SCREW, M8X20-8.8 HEX SOCKET HEAD CAP ZINC	F81002-30	1



### 5.6 Control Box Mount Bracket

MP280EH13S-V\_034  
MP280EH13S-V

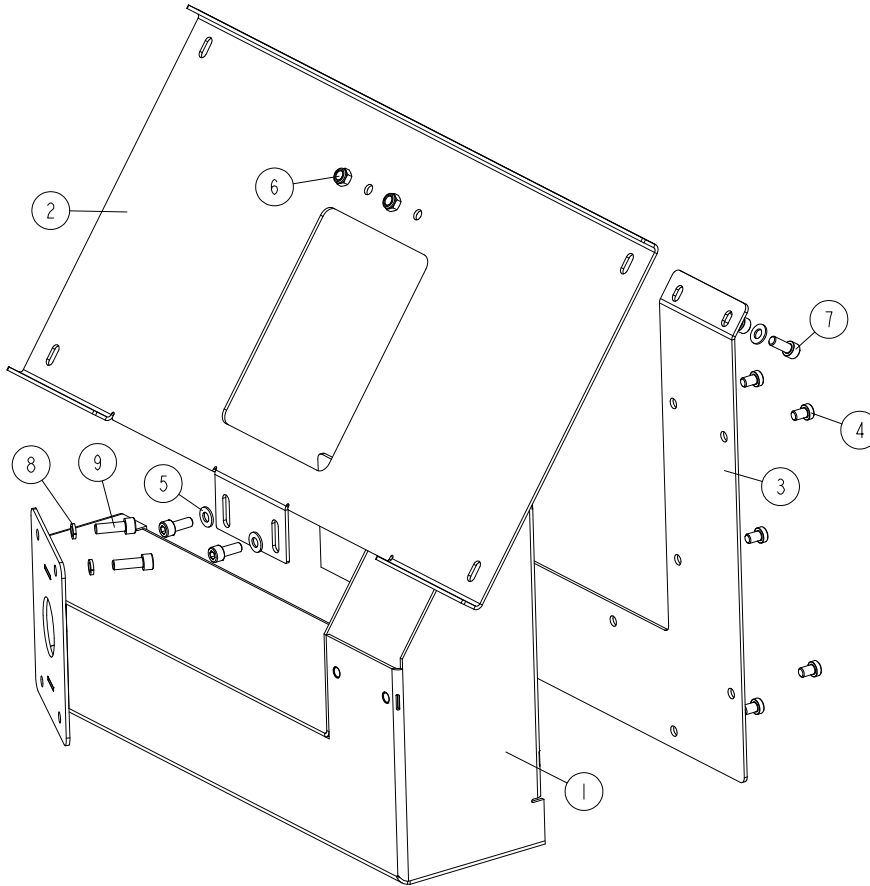

REF.	DESCRIPTION (* indicates parts available in assemblies only)	PART #	QTY
-	<b>BRACKET, ELECTRICAL BOX MOUNT - COMPLETE</b>	561935	1
1	BASE, ELECTRICAL BOX MOUNT BRACKET	561936-1	1
2	PLATE, ELECTRICAL BOX SUPPORT	561975-1	1
3	PLATE, ELECTRICAL BOX MOUNT BRACKET	561955-1	1
4	SCREW, M8X12 10.9 HEX SOCKET THIN HEAD CAP	F81002-110	8
5	WASHER, 8.4 FLAT ZINC	F81054-1	4
6	NUT, M8-8-B HEX NYLON ZINC LOCK	F81032-2	2
7	SCREW, M8X20-8.8 HEX SOCKET HEAD CAP ZINC	F81002-30	4
8	WASHER, 8.2 SPLIT LOCK ZINC	F81054-4	4
9	SCREW, M8X25-8.8 HEX SOCKET HEAD CAP ZINC	F81002-21	4

## 5.7 Control Box

546916\_001  
546916\_MANUAL

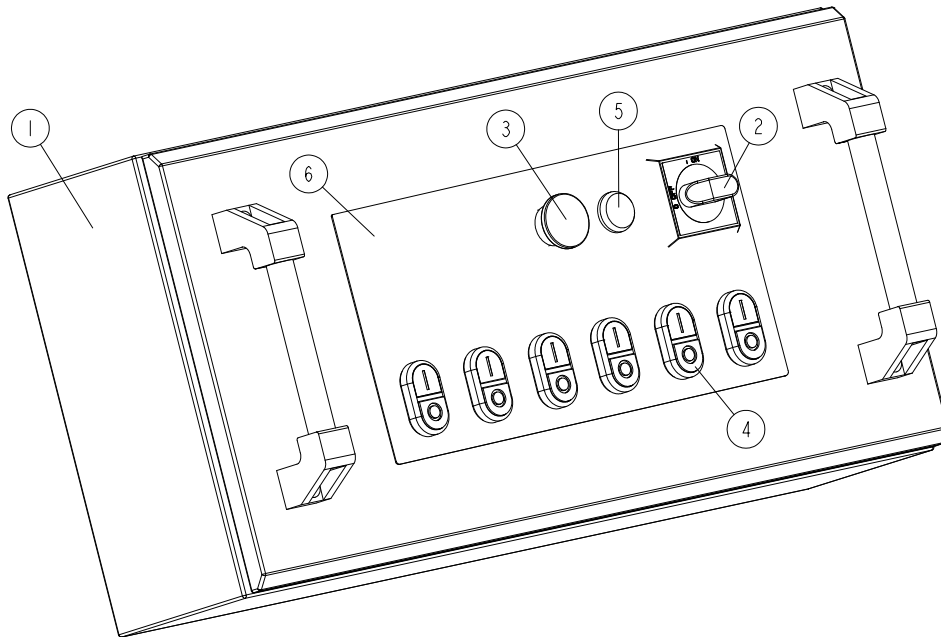

REF.	DESCRIPTION (* indicates parts available in assemblies only)	PART #	QTY	
-	<b>BOX, MP280H ELECTRICAL - COMPLETE</b>	546916	1	
1	BOX, 650X330X180	561974	1	
2	HANDLE, OHB S2A1 AB SWITCH	502312-1	1	
3	BUTTON, EMERGENCY STOP	502315	1	
4	SWITCH, XB5AW331 M5	532796	6	
5	LIGHT, XB7EV7BP WHITE CONTROL	519612	1	
6	DECAL, MP280 CONTROL BOX	585941	1	

## SECTION 6 DECALS

### 6.1 MP280 Decals

MP280EH13S-V\_DECALS  
MP280EH13S-V\_DECALS

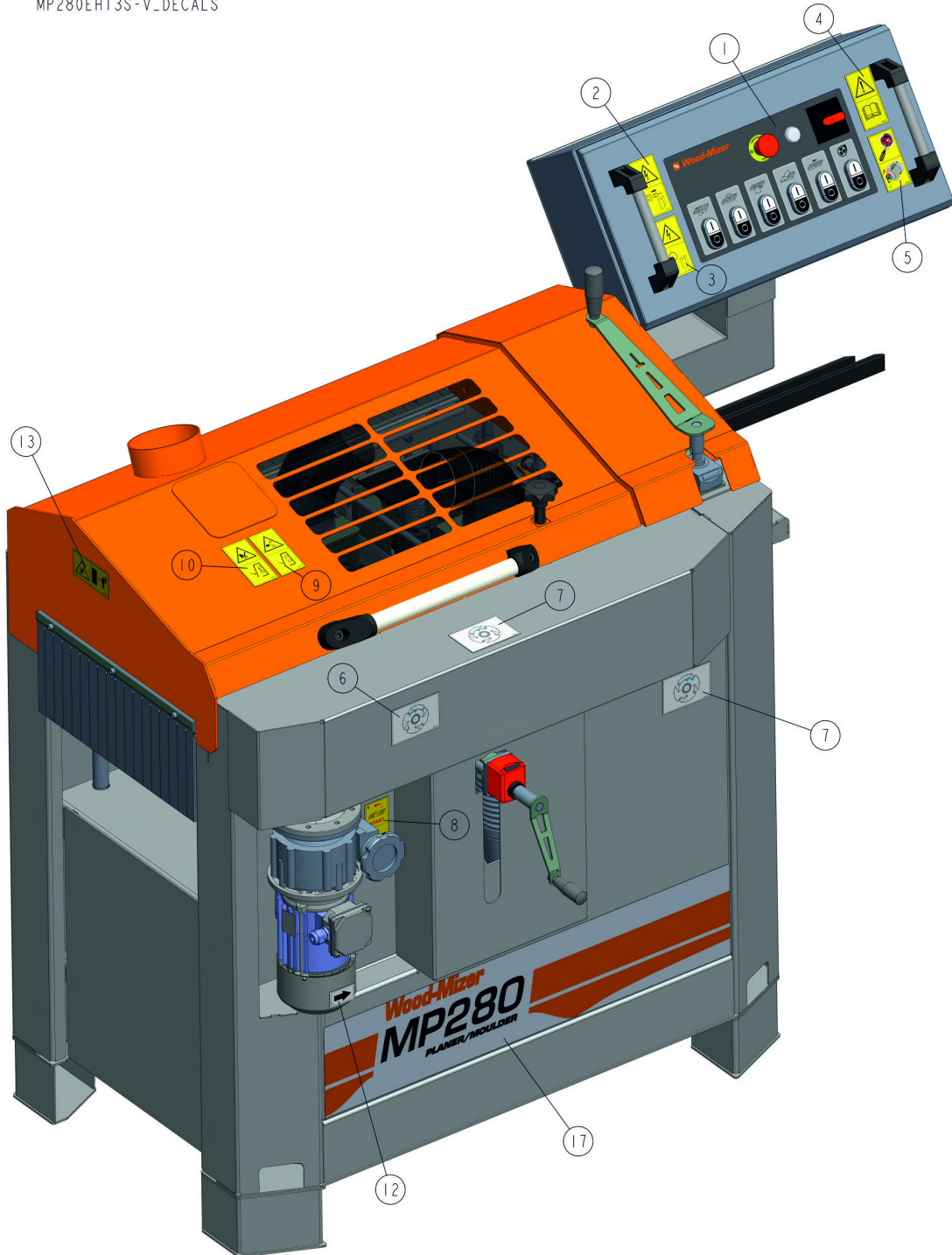

MP280EH13S-V\_DECALS  
MP280EH13S-V\_DECALS

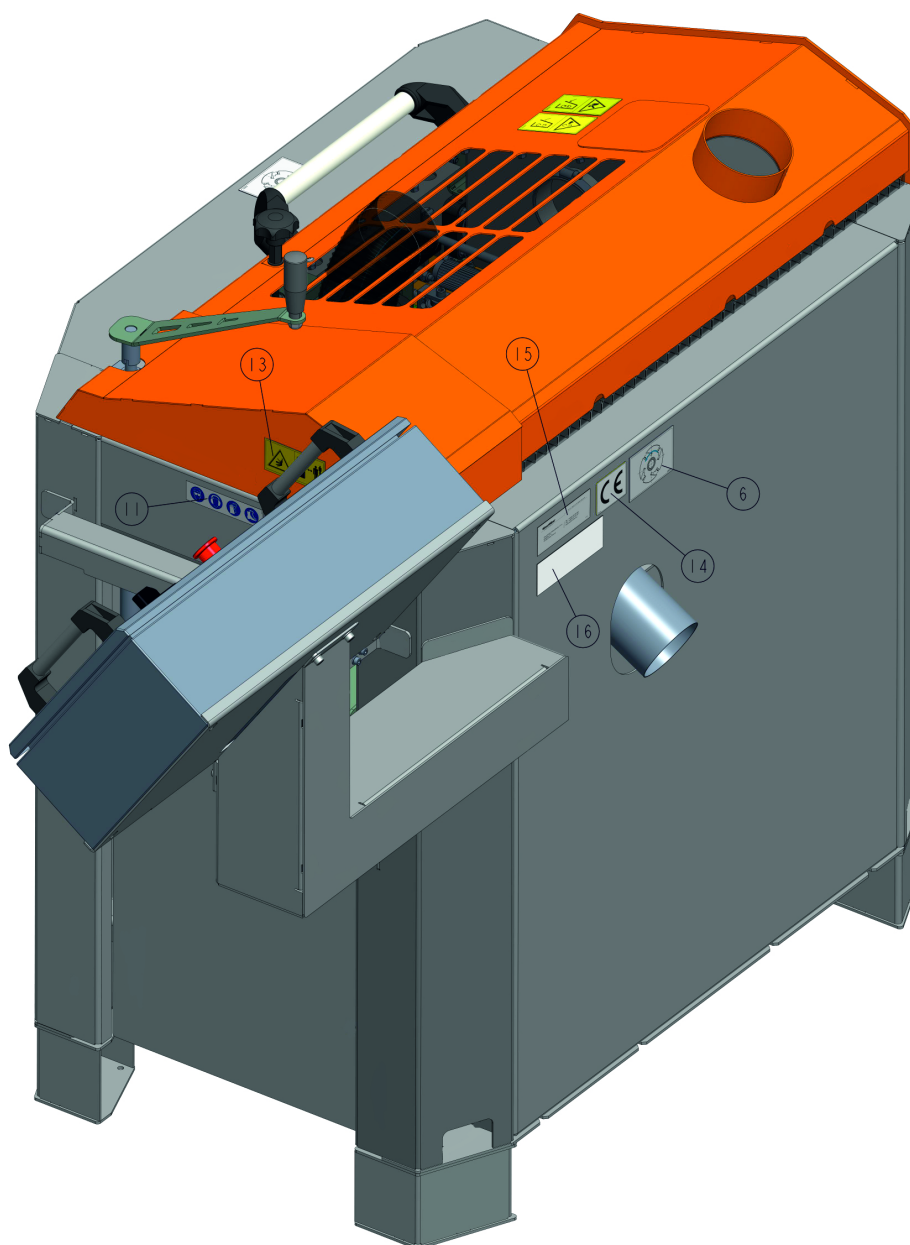

REF.	DESCRIPTION (* indicates parts available in assemblies only)	PART #	QTY	
1	DECAL, MP280 CONTROL BOX	585941	1	
2	DECAL, "REMOVE THE PLUG BEFORE OPENING THE ELECTRICAL BOX" (PICTOGRAM)	096319	1	
3	DECAL, HAZARDOUS VOLTAGE INSIDE THE ELECTRICAL BOX (PICTOGRAM)	096316	1	
4	DECAL, "READ THE OPERATOR'S MANUAL" (PICTOGRAM)	096317	1	
5	DECAL, HAZARDOUS VOLTAGE INSIDE THE ELECTRICAL BOX (PICTOGRAM)	553801	1	
6	DECAL, SHAFT ROTATION DIRECTION	539444	2	
7	DECAL, MP160 SHAFT ROTATION DIRECTION	536401	2	
8	DECAL, "USE THE CONTINUOUSLY VARIABLE TRANSMISSION WHEN THE FEED IS TURNED ON" (PICTOGRAM)	535252	1	
9	DECAL, "CLOSE GUARDS AND COVERS BEFORE OPERATING"	099220	1	
10	DECAL, HAND INJURY HAZARD (PICTOGRAM)	524993	1	

# 6 DECALS

*MP280 Decals*

---

REF.	DESCRIPTION (* indicates parts available in assemblies only)	PART #	QTY	
11	DECAL - WARNING PICTOGRAMS	535402	1	
12	DECAL, MOTOR REVOLUTIONS DIRECTION	S20097	1	
13	DECAL, "KEEP A SAFE DISTANCE" (PICTOGRAM)	099221H	2	
14	DECAL, CE CERTIFIED MACHINE - SMALL	P85070	1	
15	DECAL, EUROPEAN HEADQUARTER ADDRESS	015841	1	
16	DECAL, VIN	VIN	1	
17	DECAL, MP280 PLANER/MOULDER TYPE	586256	1	