

# **Wood-Mizer®**

## **Parts Manual**

---

**MP260**

**rev. A1.04**

---



**Safety is our #1 concern!** Read and understand all safety information and instructions before operating, setting up or maintaining this machine.

*Form #2411*

# Table of Contents

# Section-Page

<b>SECTION 1</b>	<b>GENERAL INFORMATION</b>	<b>1-1</b>
1.1	How To Use the Parts List.....	1-1
1.2	Sample Assembly .....	1-1
<b>SECTION 2</b>	<b>MP260</b>	<b>2-1</b>
2.1	MP260 .....	2-1
2.2	MP260 Additional Part Kit .....	2-2
2.3	Knives .....	2-3
2.4	Castor wheels 535166 .....	2-4
2.5	Castor wheel assembly 535163 .....	2-5
<b>SECTION 3</b>	<b>MECHANICAL ASSEMBLY</b>	<b>3-1</b>
3.1	Covers, Knife Set. ....	3-1
3.2	Table MP260 .....	3-2
3.3	Right Spindle Assembly .....	3-4
3.4	Bottom Cutter .....	3-5
3.5	Bottom Helical Cutterhead .....	3-7
3.6	Fence 1, 2 .....	3-8
3.7	Feed Assembly .....	3-10
3.8	Drive Shaft (533580) .....	3-11
3.9	Tension Plate (537535) .....	3-12
3.10	Main Shaft .....	3-13
3.11	Helical Top Cutterhead .....	3-14
3.12	Bearing Housing .....	3-15
3.13	Right Guard .....	3-16
3.14	Sawdust Outlet Guard .....	3-17
3.15	Side Guard .....	3-18
3.16	Left Guard .....	3-19
3.17	Sawdust Outlet Guard .....	3-20
3.18	Top Cover .....	3-21
3.19	Sawdust Outlet .....	3-23
3.20	Spindle Moving Assembly .....	3-24
3.21	Clamp Roller Assembly II .....	3-26
3.22	Left Spindle .....	3-27
3.23	Clamp Roller Assembly .....	3-28
3.24	Trapezoidal Screw .....	3-29
3.25	Up/Down Assembly .....	3-30
3.26	Scale .....	3-32
3.27	Handle .....	3-33
3.28	Handle .....	3-34
3.29	Chain Tension .....	3-35
3.30	Chain Slide .....	3-36
3.31	Rod Set .....	3-37

## Table of Contents

## Section-Page

3.32	Moving Plate .....	3-38
3.33	V-belt Cover (No. 537566) .....	3-39
3.34	Slide Bearing Assembly (No. 533520) .....	3-40
3.35	Feed Roller Set (No. 546806) .....	3-41
3.36	Feed Roller Set (No. 546807) .....	3-42
3.37	Guide Adjustment Tool (No. 568542) - optional equipment .....	3-43
3.38	Outfeed Guide Fence Assembly, MP260 (No. 564989) - additional equipment	3-45
<b>SECTION 4      MOTOR KITS</b>		<b>4-1</b>
4.1	Motor Kit for MP260 EH 3x400V CE .....	4-1
4.2	Side Cutter Drive .....	4-2
4.3	Horizontal Upper Cutter Drive .....	4-3
4.4	Horizontal Bottom Cutter Drive .....	4-4
4.5	Feed Drive .....	4-6
4.6	Electric Box Bracket .....	4-7
4.7	Electrical Box MP260 3x400V CE .....	4-8
<b>SECTION 5      DECALS</b>		<b>5-1</b>
5.1	Decals MP260 .....	5-1
<b>SECTION 6      TABLE MP260</b>		<b>6-1</b>
6.1	Table 265-000 .....	6-1

## SECTION 1 GENERAL INFORMATION

### 1.1 How To Use the Parts List

- Use the index above to locate the assembly that contains the part you need.
- Go to the appropriate section and locate the part in the illustration.
- Use the number pointing to the part to locate the correct part number and description in the table.
- Parts shown indented under another part are included with that part.
- Parts marked with a diamond (◆) are only available in the assembly listed above the part.

See the sample table below. Sample Part #A01111 includes part F02222-2 and subassembly A03333. Subassembly A03333 includes part S04444-4 and subassembly K05555. The diamond (◆) indicates that S04444-4 is not available except in subassembly A03333. Subassembly K05555 includes parts M06666 and F07777-77. The diamond (◆) indicates M06666 is not available except in subassembly K05555.

1.2 Sample Assembly				
REF.	DESCRIPTION (◆ Indicates Parts Available In Assemblies Only)	PART #	QTY	
	Sample Assembly, Complete (Includes All Indented Parts Below)	A01111	1	
1	Sample Part	F02222-22	1	
	Sample Subassembly (Includes All Indented Parts Below)	A03333	1	
2	Sample Part (◆ Indicates Part Is Only Available With A03333)	S04444-4	1	◆
	Sample Subassembly (Includes All Indented Parts Below)	K05555	1	
3	Sample Part (◆ Indicates Part Is Only Available With K05555)	M06666	2	◆
4	Sample Part	F07777-77	1	

#### To Order Parts:

- From Europe call our European Headquarters and Manufacturing Facility in Kolo, Poland at **+48-63-2626000**. From the continental U.S., call our toll-free Parts hotline at **1-800-525-8100**. Have your customer number, vehicle identification number, and part numbers ready when you call. From other international locations, contact the Wood-Mizer distributor in your area for parts.

#### Office Hours:

Country	Monday - Friday	Saturday	Sunday
Poland	7-15	Closed	Closed
US	8 a.m.- 5 p.m.	8 a.m.- 12 p.m.	Closed



**CAUTION!** It is strongly recommended that only original spare parts be used.

## SECTION 2 MP260

### 2.1 MP260

MP260EH13S-V\_EN\_001  
MP260EH13S-V\_MANUAL

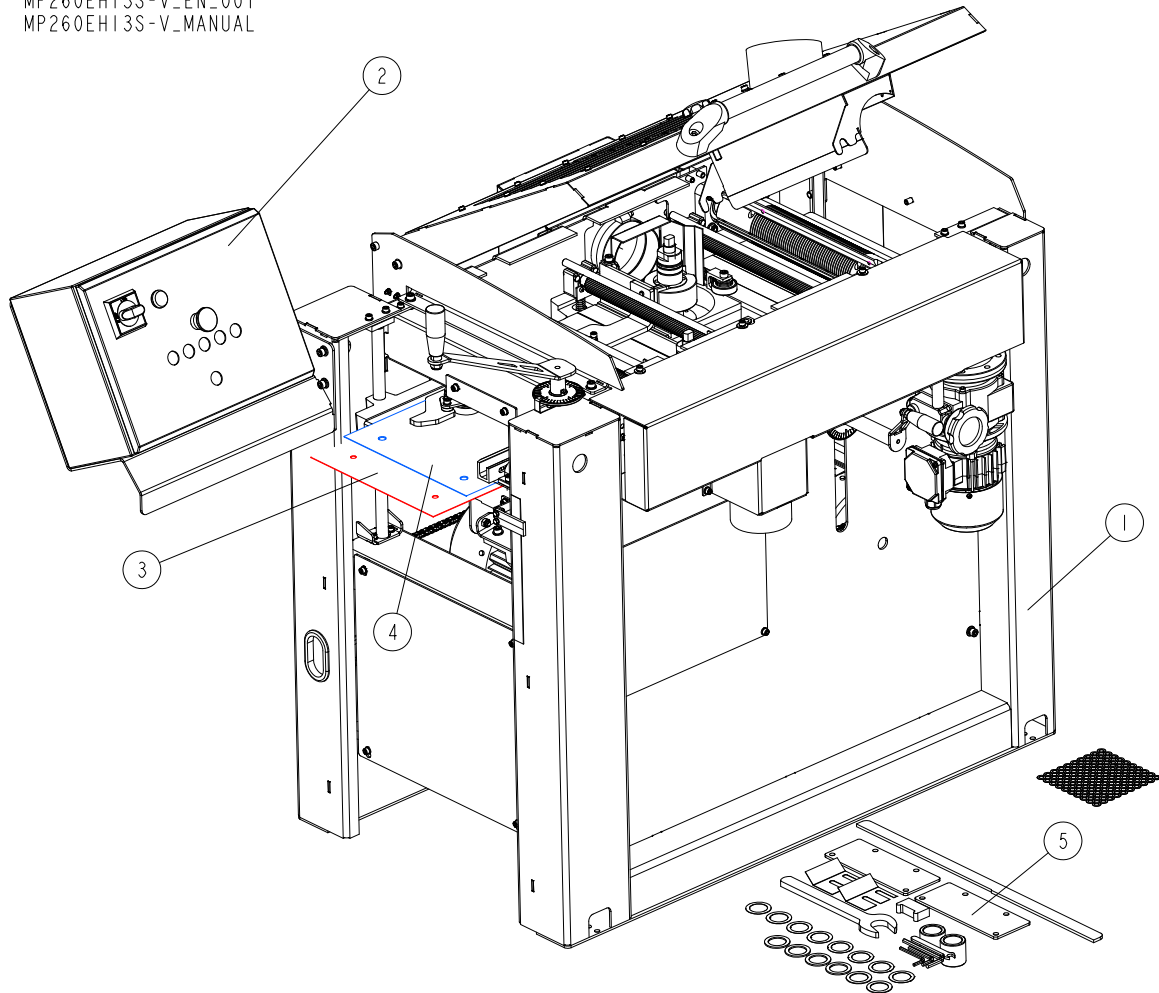

REF	DESCRIPTION (* indicates parts available in assemblies only)	PART #	QTY	
-	PLANER MOULDER MP260EH13S-V	MP260EH13S-V	1	
1	MP260- MECHANICAL ASSEMBLY <a href="#">See Section 2.3</a>	537000	1	
2	PRO MOTOR KIT FOR MP260EH 3X400V CE <a href="#">See Section 4.1</a>	537021	1	
3	PLATE 1	537576-1	1	
4	PLATE 2	537577-1	1	
5	MP260 ADDITIONAL PART KIT <a href="#">See Section 2.2</a>	537645	1	

**2.2 MP260 Additional Part Kit**

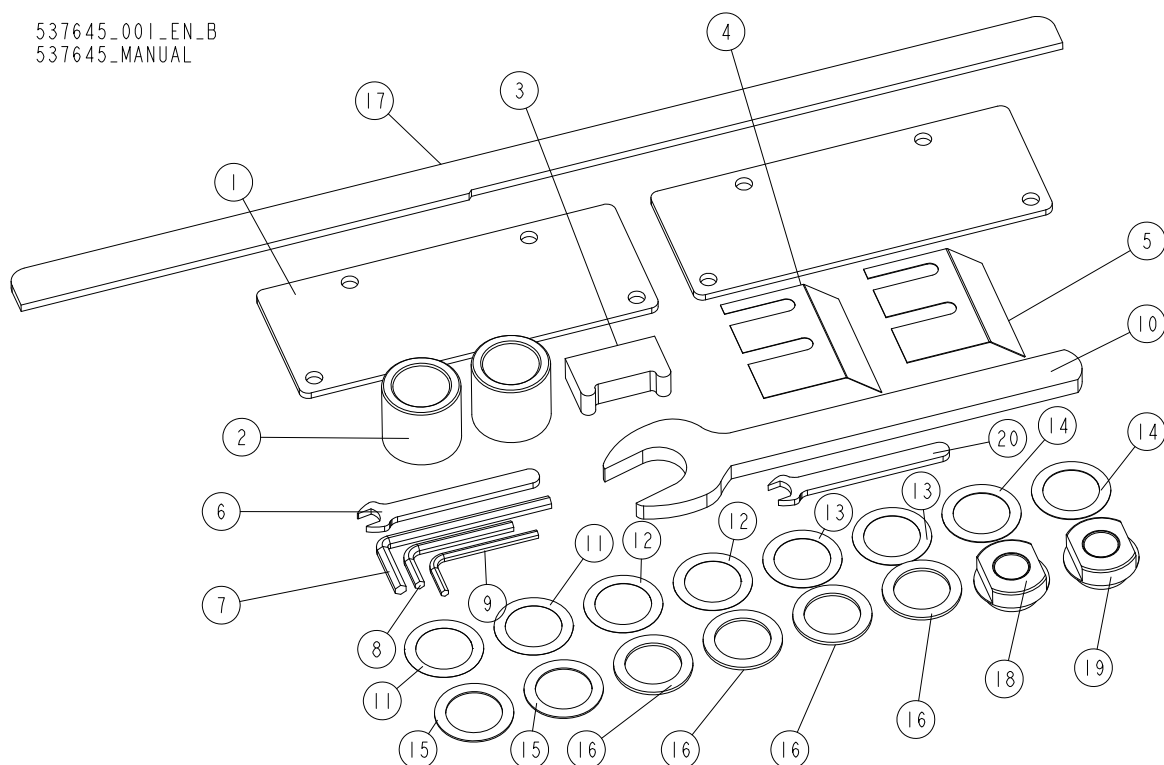
 537645\_001\_EN\_B  
 537645\_MANUAL

LP.	OPIS (* wskazuje części dostępne jedynie w zespołach)	Nr części	Ilość
-	<b>MP260 ADDITIONAL PART KIT</b>	537645	1
1	PLATE	537646-1	2
2	BUSHING 30/42-40.2 ZINC-PLATED	535848-1	2
3	KNIFE ALIGNMENT TOOL	534770	1
4	PLATE, 0.3 MM CHIP BREAKER	537648	1
5	PLATE, 0.5 MM CHIP BREAKER	533502	1
-	<b>MP160 WRENCH KIT</b>	535185	1
6	WRENCH, 10 FLAT	541315	1
7	WRENCH, 6MM ALLEN	535186	1
8	WRENCH, 5 ALLEN	092915	1
9	WRENCH, 4MM ALLEN	093368	1
10	WRENCH 30 DIN 894	537649	1
11	WASHER 30/42-0.1 ZC DIN 988	F81069-6	2
12	WASHER 30/42-0.2 ZC DIN 988	F81069-5	2
13	WASHER 30/42-0.3 ZC DIN 988	F81069-4	2
14	WASHER 30/42-0.5 ZC DIN 988	F81069-3	2
15	WASHER 30/42-1 ZC DIN 988	F81069-2	2
16	WASHER 30/42-2 ZC DIN 988	F81069-1	4
17	BAR, FENCE ADJUSTMENT	360-911	1
18	NUT, M20X1.5	542620-1	1
19	NUT, M20X1.5 LEFT	542621-1	1
20	WRENCH, 12 FLAT	564873	1

**2.3 Knives**

MP260EH13S-V\_EN\_003\_B  
MP260EH13S-V\_MANUAL

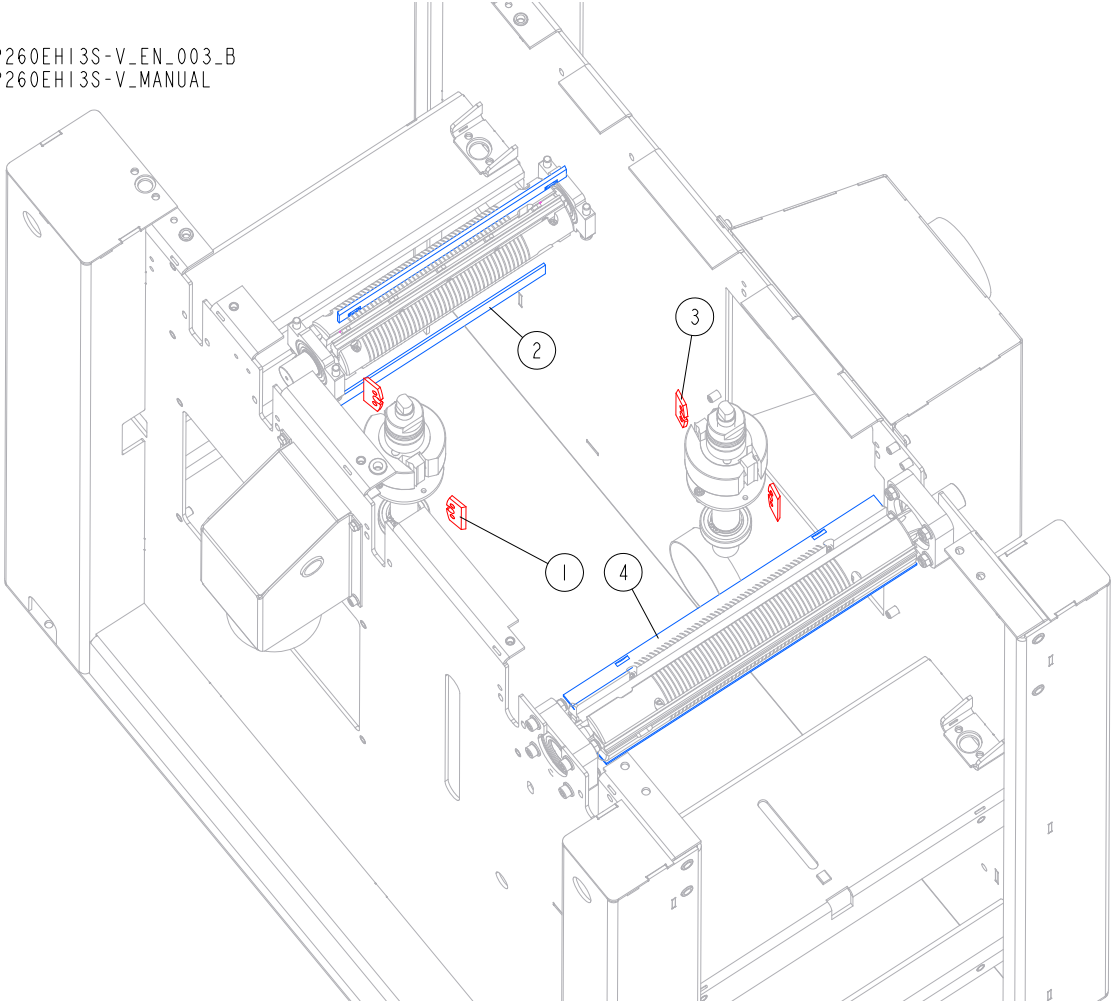

Ref	DESCRIPTION (* indicates parts available in assemblies only)	PART #	QTY
1	KNIFE, CUTTER	533588	2
-	KNIFE SET, PLANING	260-030	1
2	PLANER BLADE	TPK30020MP	2
3	KNIFE, CUTTER	533588	2
-	PLANER KNIFE WITH NOTCHES	TPK410.20MP	2
4	TPK410.20HS	TPK41020HS	2

## 2.4 Castor wheels 535166

535166\_001  
535166\_MANUAL

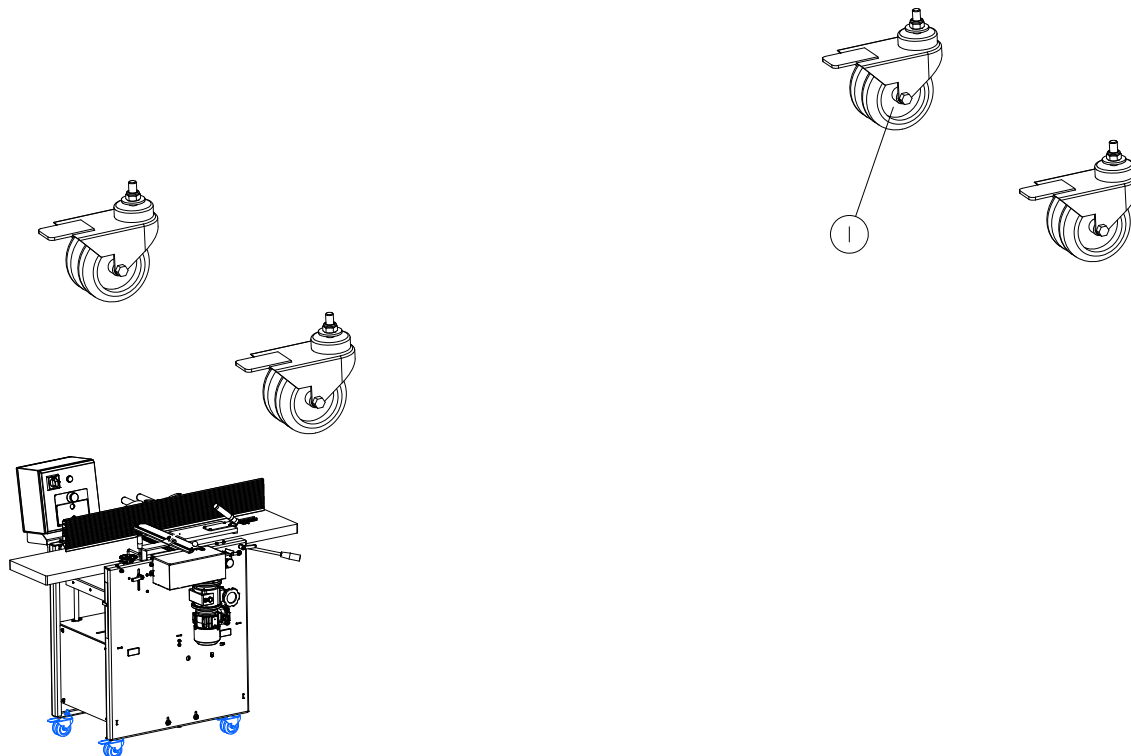

REF.	DESCRIPTION (* indicates parts available in assemblies only)	PART #	QTY	
-	CASTOR WHEELS, 4 PCS. KIT	535166	1	
1	CASTOR WHEEL ASSEMBLY <a href="#">See Section 2.5</a>	535163	4	



## 2.5 Castor wheel assembly 535163

535163\_001  
535163\_MANUAL

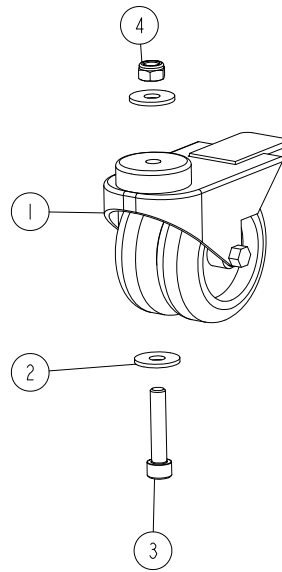

REF.	DESCRIPTION (* indicates parts available in assemblies only)	PART #	QTY	
-	<b>CASTOR WHEEL ASSEMBLY</b>	535163	1	
1	DUAL WHEEL CASTOR, KMDA-TPA 75S-HC	533510	1	
2	WASHER, ISO 7093-1-8-200 HV-A2E.	F81054-11	2	
3	SCREW, M8X40-8.8 HEX SOCKET HEAD CAP ZINC	F81002-29	1	
4	NUT, M8-8-B HEX NYLON ZINC LOCK	F81032-2	1	

## SECTION 3 MECHANICAL ASSEMBLY

### 3.1 Covers, Knife Set.

537000\_002\_EN\_B  
537000\_MANUAL

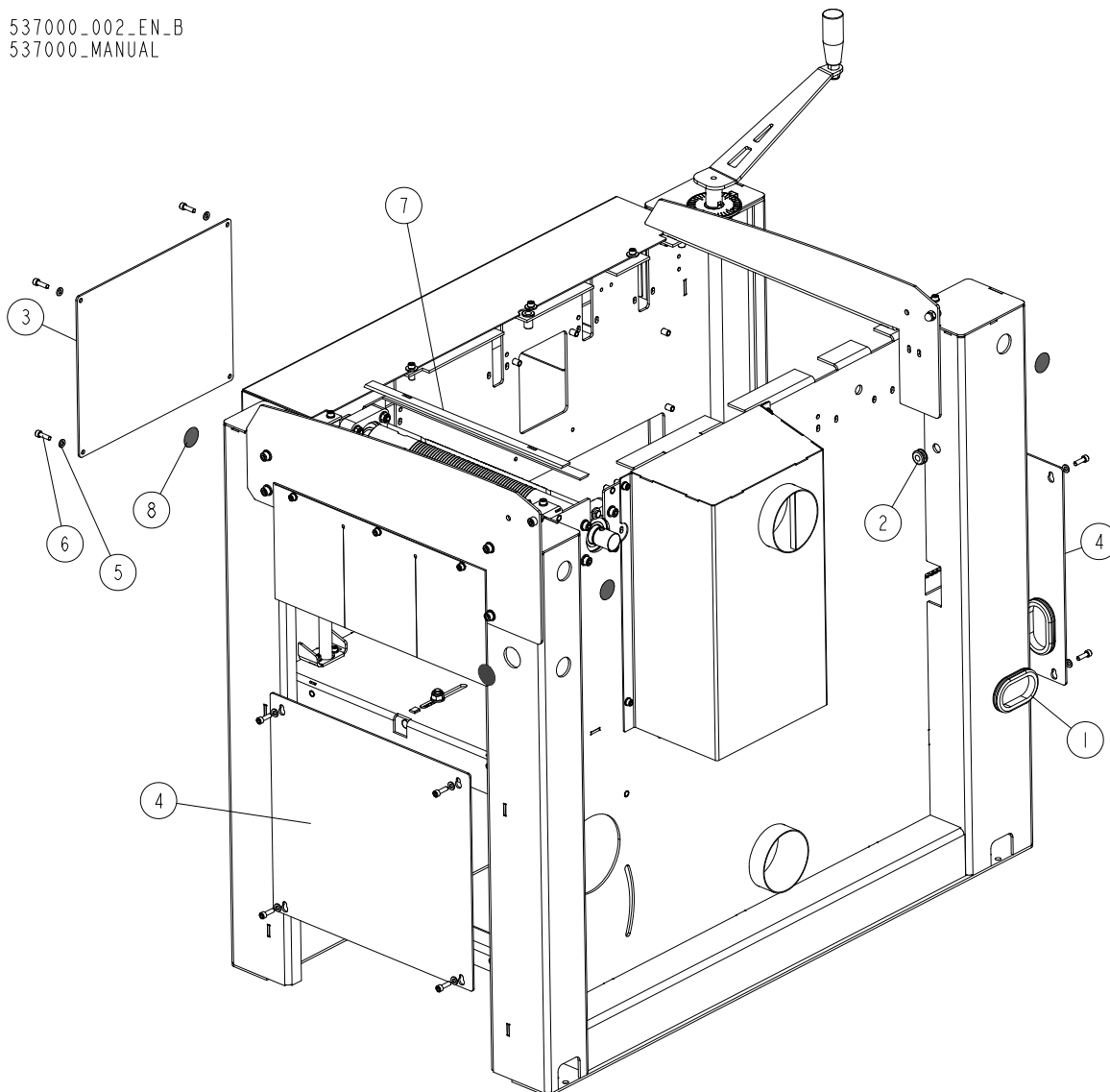

Ref	DESCRIPTION (* indicates parts available in assemblies only)	PART #	QTY
1	Grommet, Rubber	087065	2
2	GROMMET, RUBBER 3/8 ID	025248	1
3	FRONT SMALL COVER	537567-1	1
4	PLATE, SIDE	533096-1	2
5	WASHER 6,4 ZC DIN 126 ISO 7091	F81053-1	12
6	SCREW M6X20 SHCS ZC 8.8 DIN 912 ISO 4762	F81001-22	12
7	PLANER KNIFE WITH NOTCHES	TPK410.20MP	2
8	CAP, 32MM 466870 HOLE	540576	9

### 3.2 Table MP260

537004\_001\_EN\_B  
537004\_MANUAL

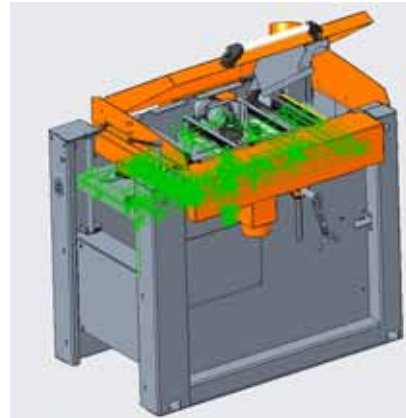
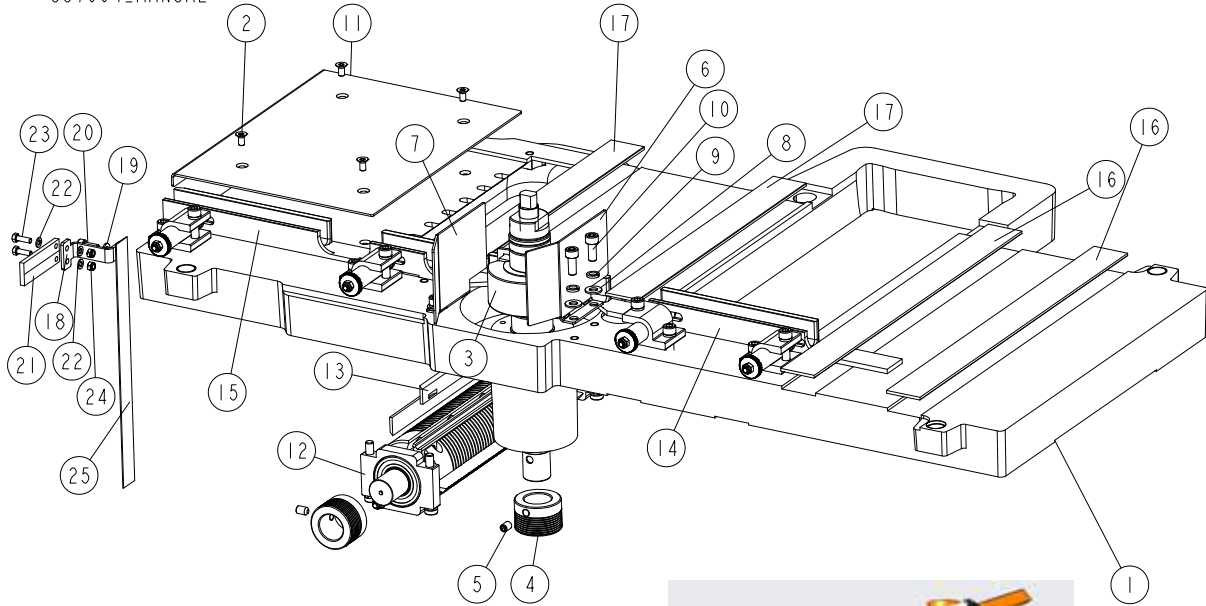

Ref	DESCRIPTION (* indicates parts available in assemblies only)	PART #	QTY
-	<b>TABLE MP260 COMPLETE</b>	537004	1
1	TABLE MP260	546836-1	1
2	SCREW M6X12 HSFH ZC 10.9 DIN 7991 ISO 10642	F81001-54	4
3	RIGHT SPINDLE ASSEMBLY <a href="#">See Section 3.3</a>	537135	1
4	PULLEY, MULTI-GROOVE SMALL ALUMINIUM	533586	2
5	SCREW M8X12 HSS W/CONE POINT ZC 45H DIN 914	F81002-105	2
6	CUTTER GUARD 1	537006	1
7	CUTTER GUARD 2	537007	1
8	WASHER 8,4 ZC DIN 126 ISO 7091	F81054-1	4
9	WASHER 8,2 ZC SPRING LOCK DIN 127	F81054-4	4
10	SCREW M8X20 SHCS ZC 8.8 DIN 912 ISO 4762	F81002-30	4
11	TABLE PLATE 1	537563-1	1
12	BOTTOM CUTTER - ASSEMBLY <a href="#">See Section 3.5</a>	537568	1
13	KNIFE SET, PLANING	260-030	1
14	FENCE 1, ASSEMBLY <a href="#">See Section 3.6</a>	537570	1
15	FENCE 2, ASSEMBLY <a href="#">See Section 3.6</a>	537572	1

Ref	DESCRIPTION (* indicates parts available in assemblies only)	PART #	QTY	
16	SLIDE PLATE 1	537573	2	
17	SLIDE PLATE 2	537574	2	
18	INDICATOR, SCALE	537559-1	1	
19	WASHER 6,4 ZC DIN 126 ISO 7091	F81053-1	1	
20	SCREW M6X16 SHCS ZC 8.8 DIN 912 ISO 4762	F81001-21	1	
21	TEFLON PLATE	094821	1	
22	WASHER 5,3 ZC DIN 126 ISO 7091	F81052-1	4	
23	BOLT M5X16 HH ZC FT 8.8 DIN 933	F81000-2	2	
24	NUT, M5-8-FE/ZN5 DIN985	F81030-2	2	
25	DECAL, VERTICAL SCALE	533579	1	

### 3.3 Right Spindle Assembly

MP280EH13S-V\_007  
 MP280EH13S-V

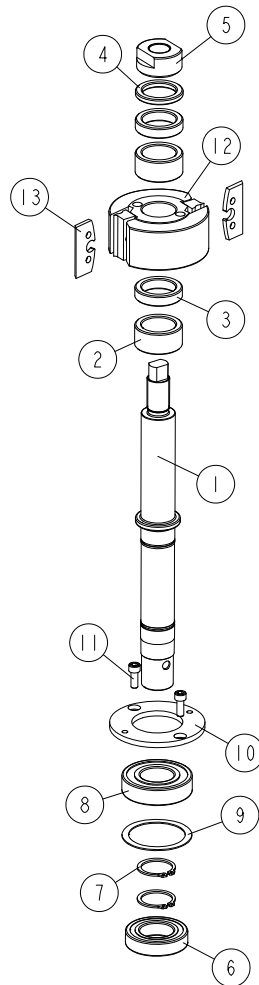

REF	DESCRIPTION (u indicates parts available in assemblies only)	PART #	QTY
-	<b>RIGHT SPINDLE ASSEMBLY</b>	537135	1
1	SHAFT	537134	1
2	BUSHING, 30/42-20.2 ZINC-PLATED	533541-1	2
3	BUSHING, 30/42-10 ZINC-PLATED	533539-1	2
4	BUSHING, 30/42-5.2 ZINC-PLATED	533540-1	1
5	NUT, M20X1.5	535886-1	1
6	BEARING, 6006 2RSR	096191	1
7	RING, Z30 SPRING RETAINING	F81090-23	2
8	BEARING, 6206 2RSR P6 ROLLING (FAG, NSK,	100787	1
9	WASHER 50X61.6X1	533543	1
10	PLATE, CLAMPING	533542-1	1
11	SCREW, M6X16 -8.8 HEX SOCKET HEAD CAP ZI	F81001-21	2
-	CUTTERHEAD	TG562K	1
12	CUTTERHEAD	533587	1
13	KNIFE, CUTTER	533588	2

### 3.4 Bottom Cutter

537568\_001\_EN  
537568\_MANUAL

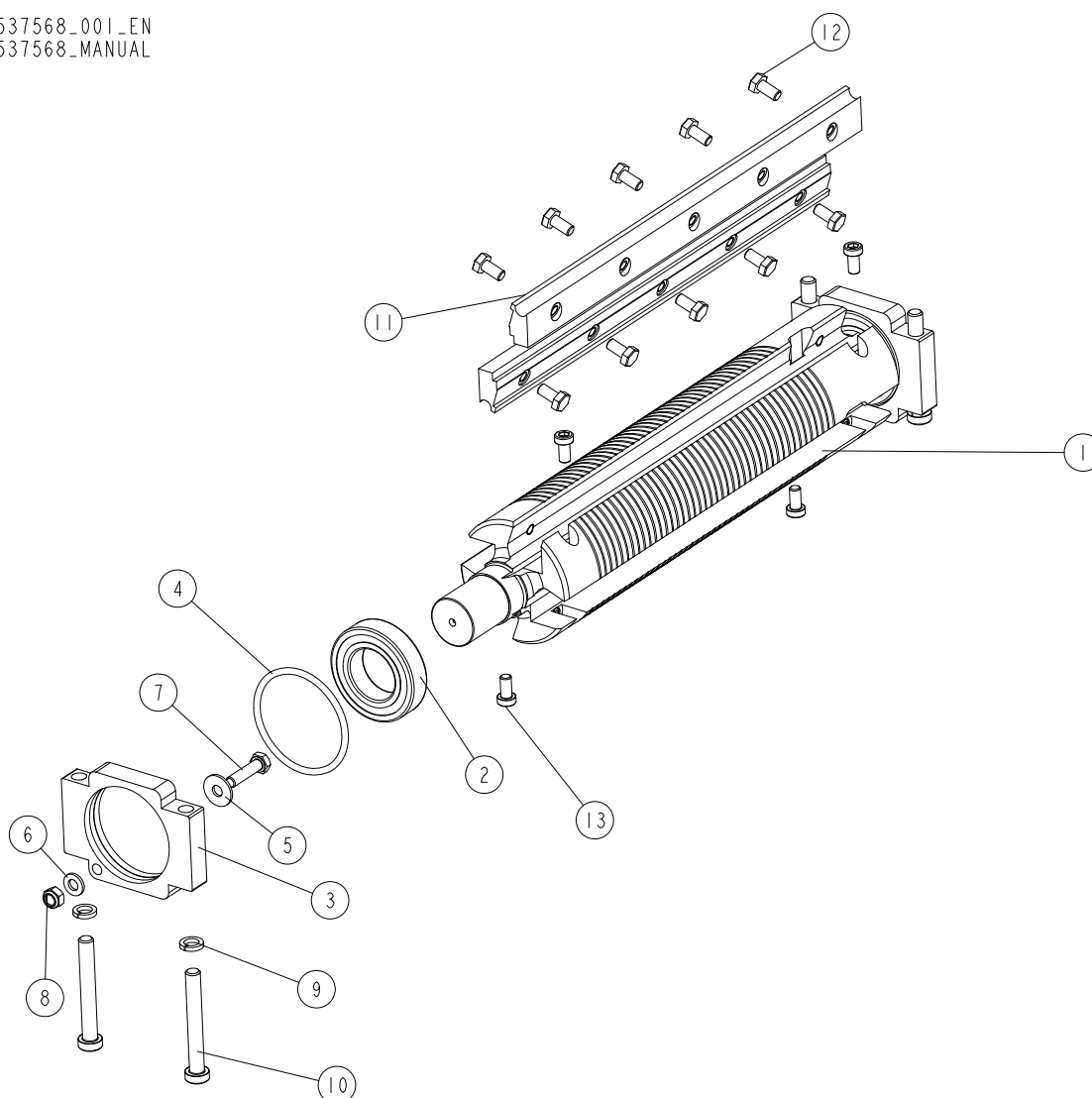

REF	DESCRIPTION (* indicates parts available in assemblies only)	PART #	QTY
-	<b>BOTTOM CUTTER - ASSEMBLY</b>	537568	1
1	LOWER CUTTER	260-140-5	1
-	BEARING KIT, LOWER CUTTER	546725-S	1
2	BEARING, 6006 2RSR	096191	2
3	BEARING HOUSING 1	536958-1	2
4	O-RING	536959	2
5	WASHER 6,5 ZC FENDER DIN 9021 ISO 7093	F81053-11	2
6	WASHER 6,4 ZC DIN 126 ISO 7091	F81053-1	2
7	BOLT M6X25 HH ZC FT 8.8 DIN 933	F81001-3	2
8	NUT M6 ZC 8 NYLOCK DIN 982 ISO 7040	F81031-2	2
9	WASHER 8,2 ZC SPRING LOCK DIN 127	F81054-4	4
10	SCREW M8X60 LHSCS 8.8 DIN 7984	F81002-41	4
11	SET OF FIXING WEDGES	241-061	1
12	BOLT M6X12 10.9 DIN 933 ISO 4017	083595	10

REF	DESCRIPTION (* indicates parts available in assemblies only)	PART #	QTY	
13	SCREW M6X12 LSHCS 10.9 DIN 7984	F81001-80	4	

# 3 MECHANICAL ASSEMBLY

## Bottom Helical Cutterhead

### 3.5 Bottom Helical Cutterhead

THH260BC-S\_001  
THH260BC-S

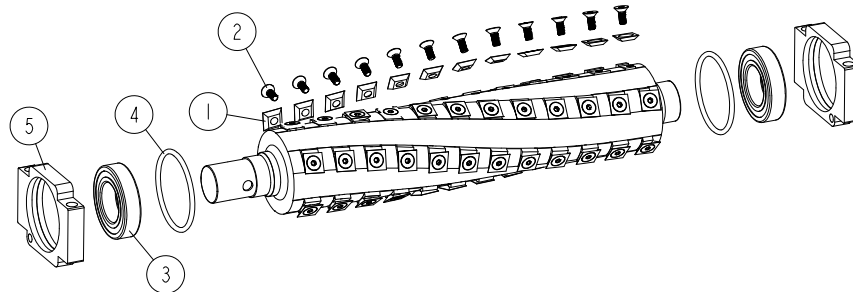

REF	DESCRIPTION (u indicates parts available in assemblies only)	PART #	QTY	
-	<b>KIT, MP260 HELICAL BOTTOM CUTTERHEAD</b>	THH260BC-S	1	
-	CUTTERHEAD, HELICAL BOTTOM THH260TC	THH260BC	1	
1	INSERT, REPLACEMENT CARBIDE	TIK19HM	60	
2	SCREW, 10-32X1/2 FH BO; TORX PLUS	F05004-325	60	
3	BEARING, 6006 2RSR	096191	2	
4	O-RING	536959	2	
5	HOUSING, BEARING	564942-1	2	



### 3.6 Fence 1, 2

537570\_001\_EN\_A  
537570\_MANUAL

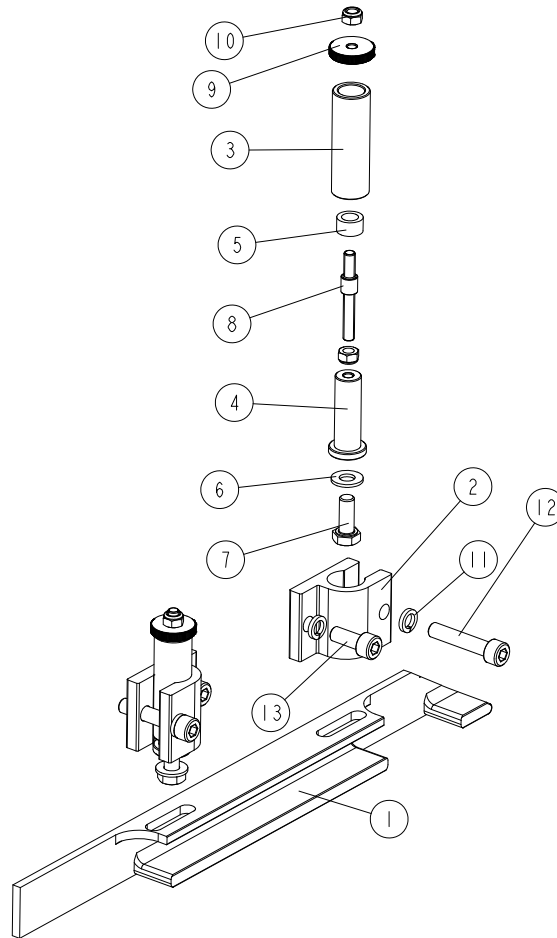

Ref	DESCRIPTION (* indicates parts available in assemblies only)	PART #	QTY	
-	<b>FENCE 1, ASSEMBLY</b>	537570	1	
-	<b>FENCE 2, ASSEMBLY</b>	537572	1	
1	FENCE 1	537569-1 <sup>1</sup>	1	
	FENCE 2	537571-1 <sup>2</sup>	1	
	FENCE, 700 MM	542454-1 <sup>3</sup>	1	
	FENCE, 1400 MM	542453-1 <sup>4</sup>	1	
2	CLAMP	536966-1	2	
-	ADJUSTABLE KNOB	536965	2	
3	PIN GUIDE	537001-1	1	
4	KNOB PIN	536999-1	1	
5	INSERT	537002	1	
6	WASHER 8,4 ZC DIN 126 ISO 7091	F81054-1	1	
7	BOLT M8X20 HH ZC FT 8.8 DIN 933	F81002-4	1	
8	THREAD PIN M6	541455	1	
9	KNURLED NUT	541454	1	
10	NUT, M6, HEXAGON,FREE, GRADE 5(8.8)ZINC	F81031-1	1	
10	NUT M6 ZC 8 NYLOCK DIN 982 ISO 7040	F81031-2	1	
11	WASHER 8,2 ZC SPRING LOCK DIN 127	F81054-4	4	

# 3 MECHANICAL ASSEMBLY

Fence 1, 2

---

Ref	DESCRIPTION (* indicates parts available in assemblies only)	PART #	QTY	
12	SCREW M8X40 SHCS ZC 8.8 DIN 912 ISO 4762	F81002-29	2	
13	SCREW M8X20 SHCS ZC 8.8 DIN 912 ISO 4762	F81002-30	2	

<sup>1</sup> Included in 537570

<sup>2</sup> Included in 537572

<sup>3</sup> Longer Fence - 700mm

<sup>4</sup> Long Fence - 1400mm

### 3.7 Feed Assembly

536997\_001\_EN\_B  
536997\_MANUAL

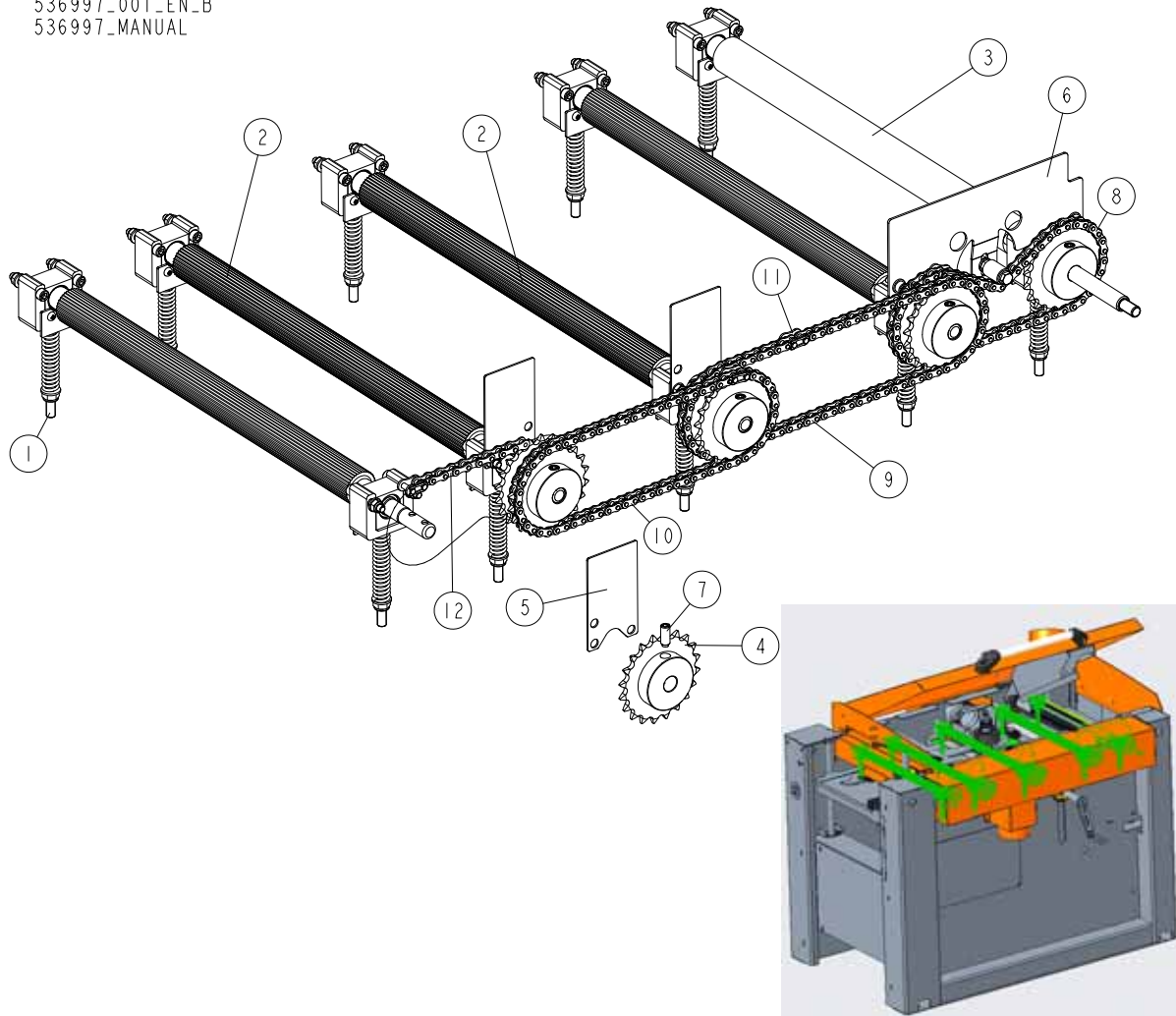

Ref	DESCRIPTION (* indicates parts available in assemblies only)	PART #	QTY
-	<b>FEED ASSEMBLY, MP260</b>	536997	1
1	DRIVE SHAFT ASSEMBLY <a href="#">See Section 3.8</a>	533580	2
2	DRIVE SHAFT ASSEMBLY <a href="#">See Section 3.8</a>	537585	2
3	SHAFT ASSEMBLY, W/PROTECTIVE COVER <a href="#">See Section 3.8</a>	533581	1
4	SPROCKET Z=20; 1/2"X 3/16" CHAIN 083-1)	533109	8
5	BUSHING HOUSING PLATE	536998-1	3
6	TENSION PLATE COMPLETE <a href="#">See Section 3.9</a>	537535	1
7	SCREW M8X20 HSS W/DOG POINT ZC 45H DIN 915 ISO 4028	F81002-77	8
8	CHAIN 083-1; P=1/2"; LENGHT=0,5461M (43 LINKS)	537052	1
9	CHAIN 083-1; P=1/2"; LENGHT=0,7239M (57 LINKS)	537053	1
10	CHAIN 083-1; P=1/2"; LENGHT=0,6477M (51 LINKS)	537054	1
11	CONNECTING LINK FOR CHAIN 083-1	533128	4
12	CHAIN 083-1; P-1/2"; LENGHT=0,4953M (39 LINKS)	534393	1

**3.8 Drive Shaft (533580)**

533580-001\_A  
 533580\_MANUAL

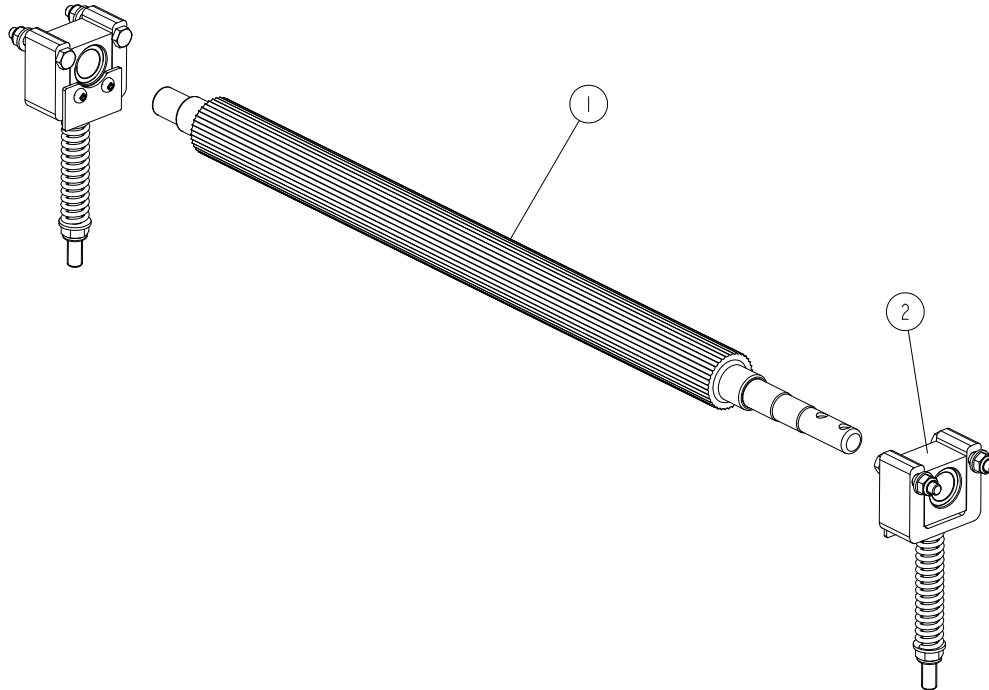

REF	DESCRIPTION (* indicates parts available in assemblies only)	PART #	QTY	
-	DRIVE SHAFT ASSEMBLY	533580	1	
-	DRIVE SHAFT ASSEMBLY	537585	1	
-	DRIVE SHAFT ASSEMBLY	533581	1	
1	SHAFT, STEEL DRIVE	533513-1 <sup>1</sup>	1	
	SHAFT, STEEL DRIVE	537586-1 <sup>2</sup>	1	
	SHAFT W/PROTECTIVE COVER	533512 <sup>3</sup>	1	
2	BEARING ASSEMBLY, SLIDE <a href="#">See Section 3.34</a>	533520	2	

<sup>1</sup> Included in 533580

<sup>2</sup> Included in 537585

<sup>3</sup> Included in 533581

### 3.9 Tension Plate (537535)

537535\_001\_EN  
 537535\_MANUAL

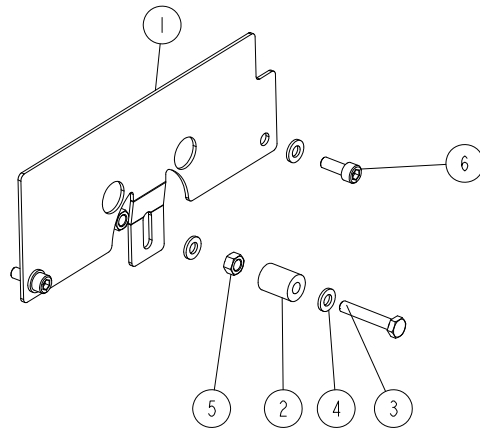

REF	DESCRIPTION (* indicates parts available in assemblies only)	PART #	QTY
-	<b>TENSION PLATE COMPLETE</b>	537535	1
1	TENSION PLATE	537534-1	1
2	BUSHING, SPACER	R80671-6	1
3	BOLT M6X35 HH ZC 8.8 PT DIN 931	F81001-71	1
4	WASHER 6,4 ZC DIN 126 ISO 7091	F81053-1	4
5	NUT M6 ZC 8 DIN 934	F81031-1	2
6	SCREW M6X16 SHCS ZC 8.8 DIN 912 ISO 4762	F81001-21	2

### 3.10 Main Shaft

533682\_001\_B  
533682\_MANUAL

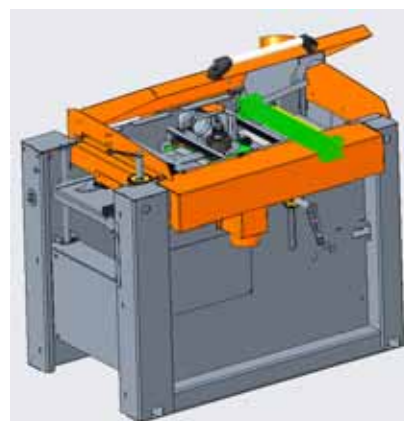
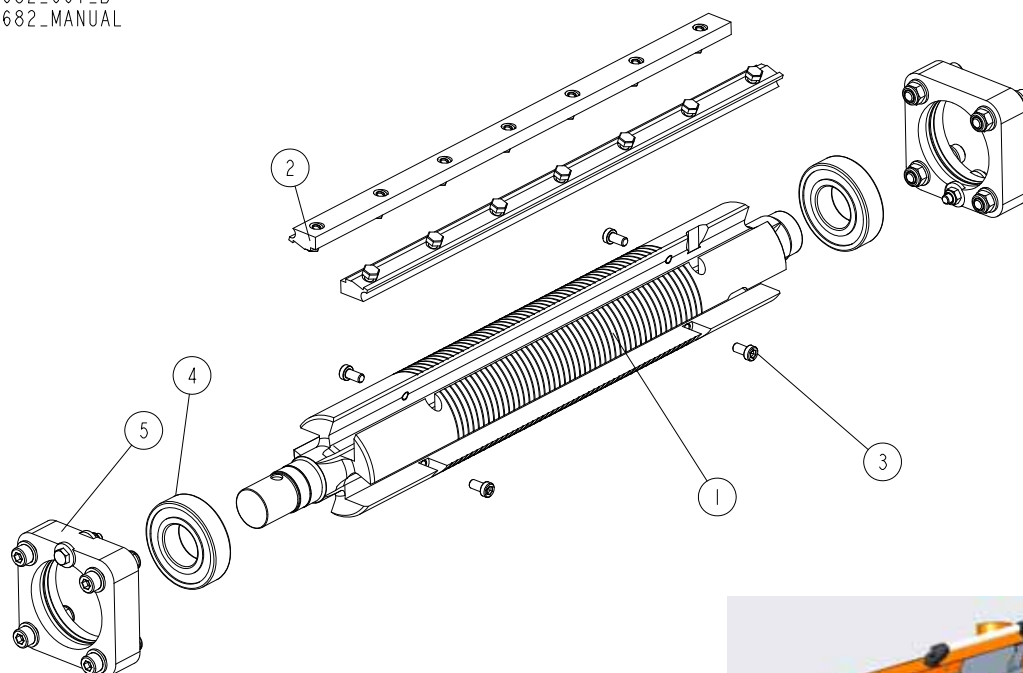

REF	DESCRIPTION (* indicates parts available in assemblies only)	PART #	QTY
-	<b>SHAFT ASSEMBLY, DRIVE</b>	533682	1
1	SHAFT, MAIN	260-138	1
2	MOUNTING WEDGES	241-060	1
3	SCREW M6X12 LSHCS 10.9 DIN 7984	F81001-80	4
4	BEARING, 6206 2RSR P6 ROLLING (FAG, NSK, SKF)	100787	2
5	HOUSING ASSEMBLY, BEARING <a href="#">See Section 3.12</a>	533593	2

### 3.11 Helical Top Cutterhead

THH260TC-S\_001  
 THH260TC-S

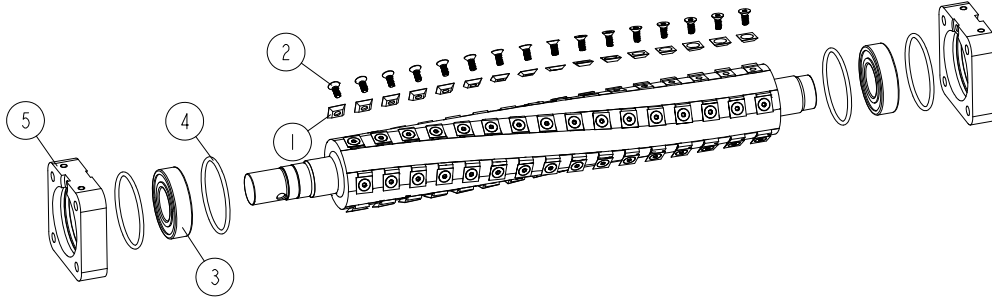

REF	DESCRIPTION (u indicates parts available in assemblies only)	PART #	QTY	
-	<b>KIT, MP260 HELICAL TOP CUTTERHEAD</b>	THH260TC-S	1	
-	CUTTERHEAD, HELICAL THH260TC	THH260TC	1	
1	INSERT, REPLACEMENT CARBIDE	TIK19HM	80	
2	SCREW, 10-32X1/2 FH BO; TORX PLUS	F05004-325	80	
3	BEARING, 6206 2RSR P6 ROLLING (FAG, NSK,	100787	2	
4	O-RING, BEARING HOUSING	533592	4	
5	HOUSING, BEARING	533590-1	2	

### 3.12 Bearing Housing

533593-001  
 533593\_MANUAL

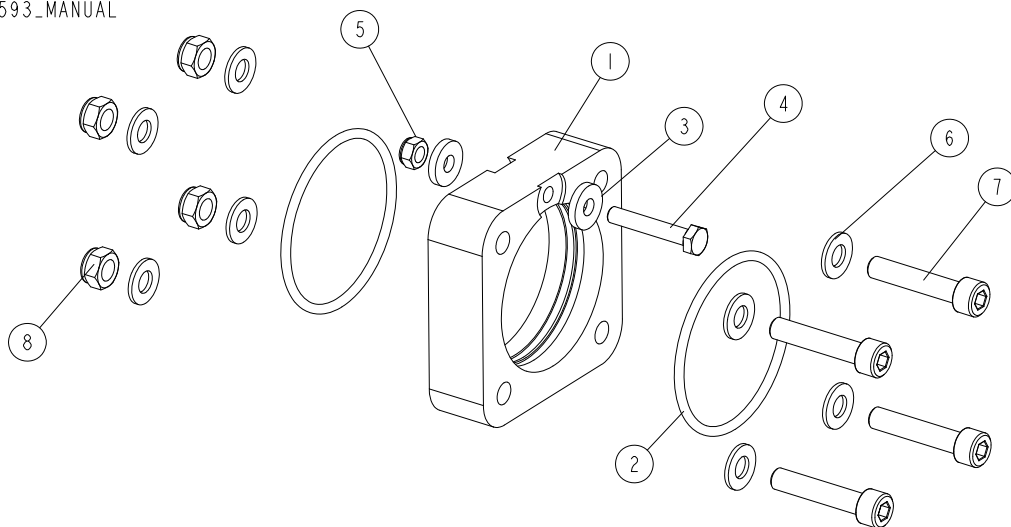

REF	DESCRIPTION (* indicates parts available in assemblies only)	PART #	QTY
-	<b>HOUSING ASSEMBLY, BEARING</b>	533593	1
1	HOUSING, BEARING	533590-1	1
2	O-RING, BEARING HOUSING	533592	2
3	WASHER 6,4 ZC DIN 7349	F81053-13	2
4	BOLT M6X35 HH ZC 8.8 PT DIN 931	F81001-71	1
5	NUT M6 ZC 8 NYLOCK DIN 982 ISO 7040	F81031-2	1
6	WASHER 8,4 ZC DIN 126 ISO 7091	F81054-1	8
7	SCREW M8X40 SHCS ZC 8.8 DIN 912 ISO 4762	F81002-29	4
8	NUT M8 ZC 8 NYLOCK DIN 982 ISO 7040	F81032-2	4



### 3.13 Right Guard

537550\_001\_EN  
537550\_MANUAL

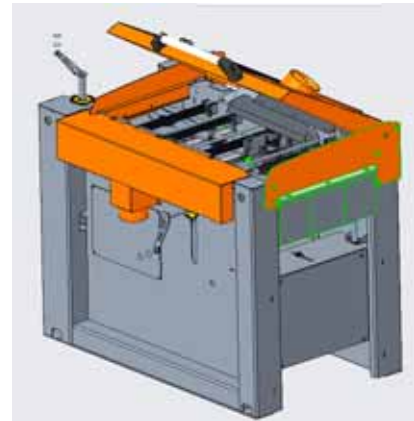
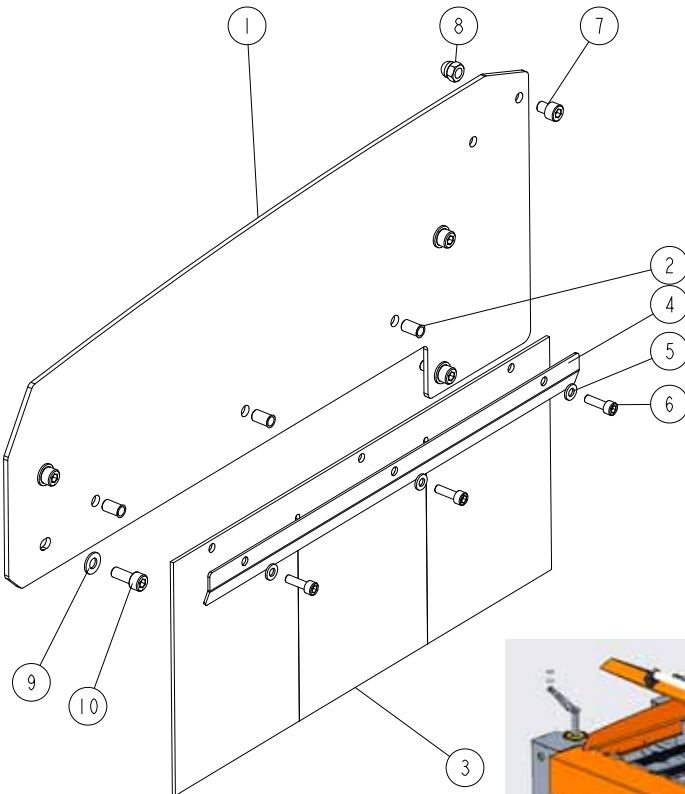

REF	DESCRIPTION (* indicates parts available in assemblies only)	PART #	QTY
-	<b>RIGHT GUARD COMPLETE</b>	537550	1
1	RIGHT GUARD PLATE	537548-1	1
2	RIVET NUT M6 1.5-4.0 W/ COUNTERSUNK HEAD AND KNURLED SHANK	F81031-13	3
3	FLEXIBLE GUARD	533083	1
4	BRACKET, FLEXIBLE GUARD	537551-1	1
5	WASHER 6,4 ZC DIN 126 ISO 7091	F81053-1	3
6	SCREW M6X20 SHCS ZC 8.8 DIN 912 ISO 4762	F81001-22	3
7	BOLT M8X10 SHCS ZC PT 8.8 DIN 912 ISO 4762	F81002-32	1
8	ACORN NUT M8 ZC 6 DIN 1587	F81033-25	1
9	WASHER 8,4 ZC DIN 126 ISO 7091	F81054-1	4
10	SCREW M8X20 SHCS ZC 8.8 DIN 912 ISO 4762	F81002-30	4

### 3.14 Sawdust Outlet Guard

537533\_001\_EN\_A  
537533\_MANUAL

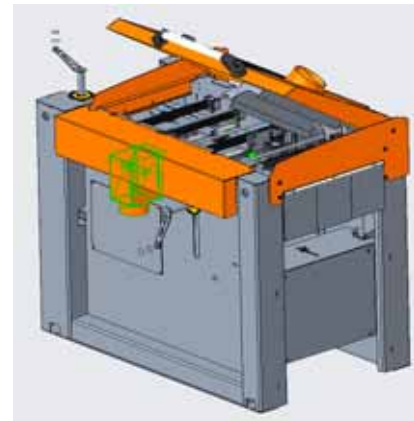
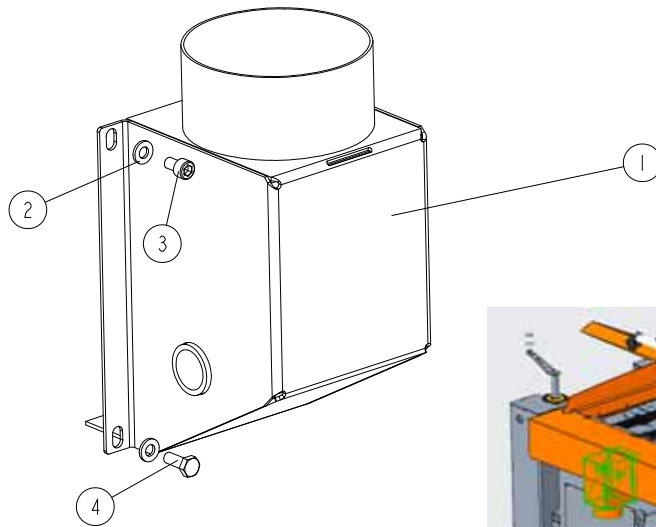

REF	DESCRIPTION (* indicates parts available in assemblies only)	PART #	QTY	
-	<b>SAWDUST OUTLET GUARD COMPLETE</b>	537533	1	
1	SAWDUST OUTLET GUARD	537530-1	1	
2	WASHER 6,4 ZC DIN 126 ISO 7091	F81053-1	4	
3	BOLT M6X10 SHCS ZC PT 8.8 DIN 912 ISO 4762	F81001-12	2	
4	BOLT M6X16 HH ZC FT 8.8 DIN 933	F81001-15	2	

### 3.15 Side Guard

537525\_001\_EN  
537525\_MANUAL

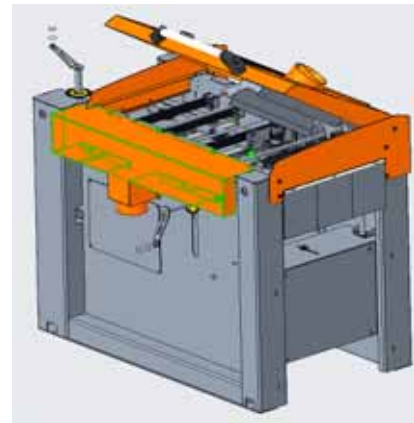
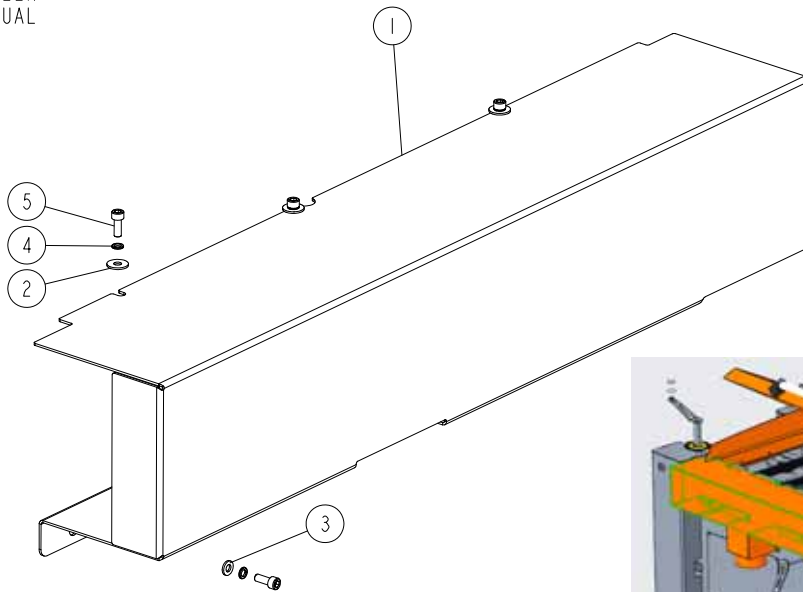

REF	DESCRIPTION (* indicates parts available in assemblies only)	PART #	QTY	
-	<b>SIDE GUARD COMPLETE</b>	537525	1	
1	SIDE GUARD	537524-1	1	
2	WASHER 6,5 ZC FENDER DIN 9021 ISO 7093	F81053-11	3	
3	WASHER 6,4 ZC DIN 126 ISO 7091	F81053-1	2	
4	WASHER 6,1 ZC SPRING LOCK DIN 127	F81053-3	5	
5	SCREW M6X16 SHCS ZC 8.8 DIN 912 ISO 4762	F81001-21	5	

### 3.16 Left Guard

537553\_001\_EN  
537553\_MANUAL

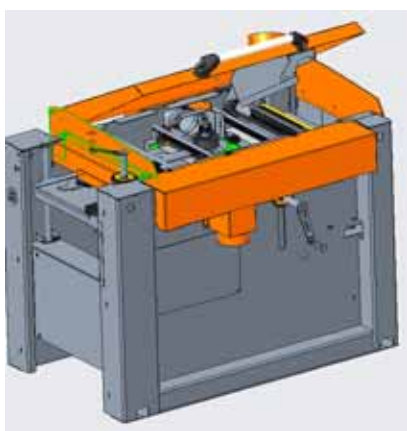
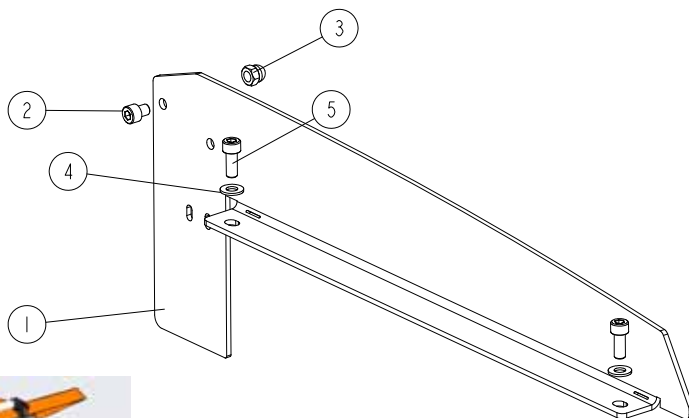

REF	DESCRIPTION (* indicates parts available in assemblies only)	PART #	QTY
-	<b>LEFT GUARD COMPLETE</b>	537553	1
1	LEFT GUARD PLATE	537552-1	1
2	BOLT M8X10 SHCS ZC PT 8.8 DIN 912 ISO 4762	F81002-32	1
3	ACORN NUT M8 ZC 6 DIN 1587	F81033-25	1
4	WASHER 8,4 ZC DIN 126 ISO 7091	F81054-1	2
5	SCREW M8X20 SHCS ZC 8.8 DIN 912 ISO 4762	F81002-30	2

### 3.17 Sawdust Outlet Guard

537523\_001\_EN  
537523\_MANUAL

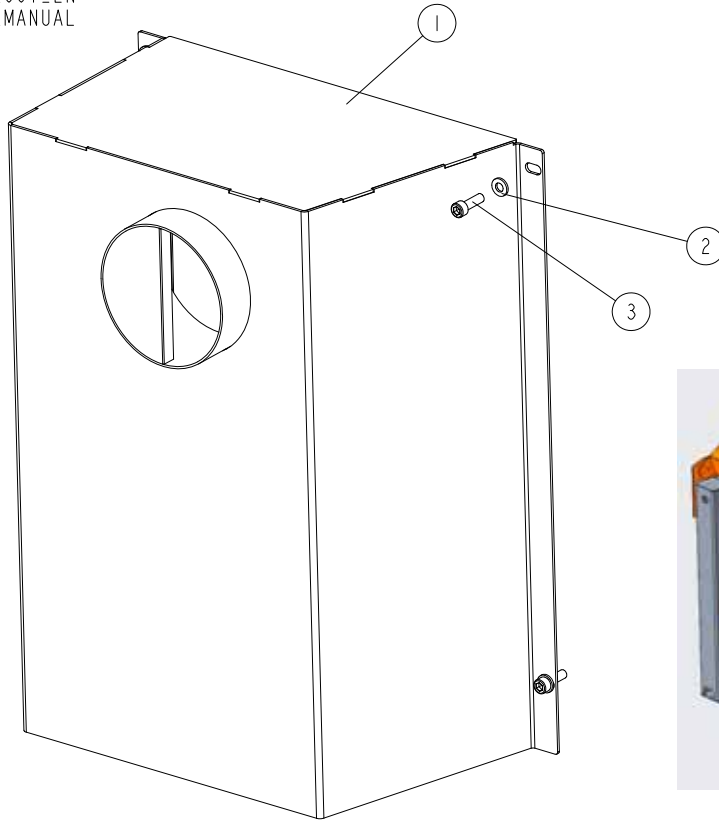

REF	DESCRIPTION (* indicates parts available in assemblies only)	PART #	QTY
-	<b>SAWDUST OUTLET GUARD COMPLETE</b>	537523	1
1	SAWDUST OUTLET GUARD	537520-1	1
2	WASHER 6,4 ZC DIN 126 ISO 7091	F81053-1	4
3	SCREW M6X20 SHCS ZC 8.8 DIN 912 ISO 4762	F81001-22	4

### 3.18 Top Cover

536986\_001\_EN  
536986\_MANUAL

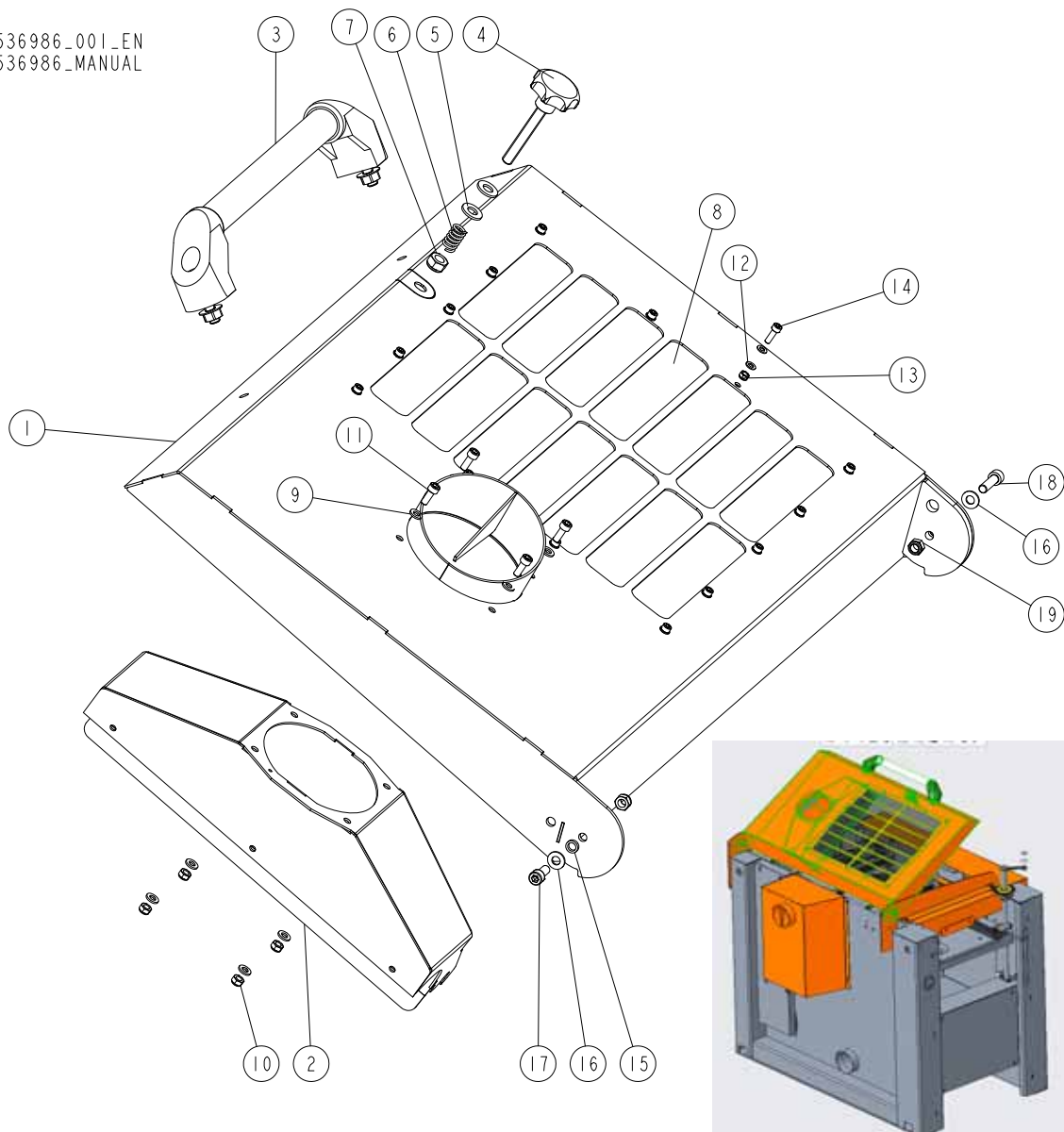

REF	DESCRIPTION (* indicates parts available in assemblies only)	PART #	QTY
-	<b>TOP COVER ASSEMBLY</b>	536986	1
1	TOP COVER WELDMENT	536985-1	1
2	SAWDUST OUTLET WELDMENT	537555-1	1
3	TUBULAR HANDLE	535614	1
-	STAR KNOB	533685	1
4	KNOB, STAR	533683	1
5	WASHER 10,5 ZC DIN 126 ISO 7091	F81055-1	2
6	SPRING	533677	1
7	NUT M10 ZC 8 NYLOCK DIN 982 ISO 7040	F81033-1	1
8	INSPECTION WINDOW PLATE	536987	1
9	WASHER 6,4 ZC DIN 126 ISO 7091	F81053-1	8
10	NUT M6 ZC 8 NYLOCK DIN 982 ISO 7040	F81031-2	4
11	SCREW M6X16 SHCS ZC 8.8 DIN 912 ISO 4762	F81001-21	4

REF	DESCRIPTION (* indicates parts available in assemblies only)	PART #	QTY	
12	WASHER 5,3 ZC DIN 126 ISO 7091	F81052-1	28	
13	NUT, M5-8-FE/ZN5 DIN985	F81030-2	14	
14	BOLT M5X16 SHCS ZC PT 8.8 DIN 912 ISO 4762	F81000-25	14	
15	BUSHING, SPACER	533674	2	
16	WASHER 8,4 ZC DIN 126 ISO 7091	F81054-1	2	
17	SCREW M8X20 SHCS ZC 8.8 DIN 912 ISO 4762	F81002-30	1	
18	SCREW M8X30 SHCS ZC 8.8 DIN 912 ISO 4762	F81002-31	1	
19	NUT M8 ZC 8 NYLOCK DIN 982 ISO 7040	F81032-2	2	

### 3.19 Sawdust Outlet

537547\_001\_EN  
537547\_MANUAL

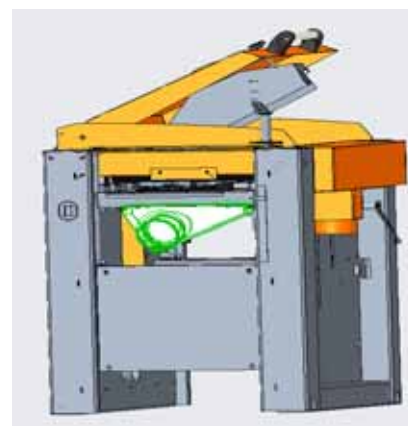
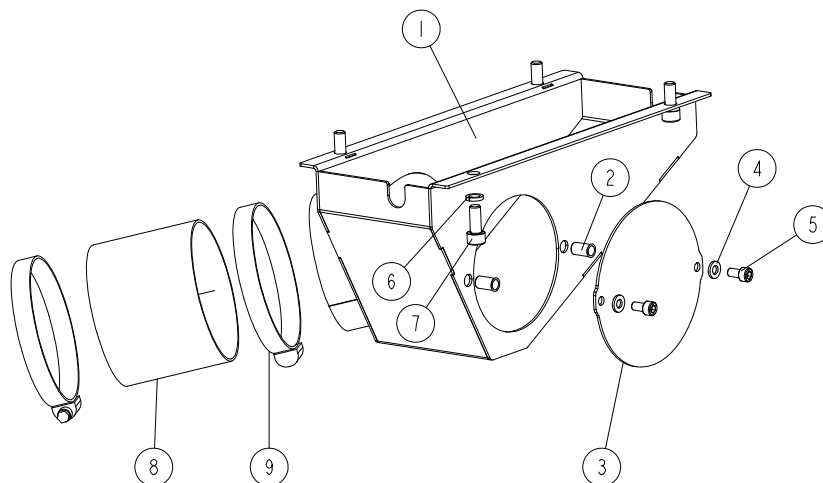

REF	DESCRIPTION (* indicates parts available in assemblies only)	PART #	QTY
-	<b>SAWDUST OUTLET COMPLETE</b>	537547	1
1	SAWDUST OUTLET	537546-1	1
2	RIVET NUT M6 1.5-4.0 W/ COUNTERSUNK HEAD AND KNURLED SHANK	F81031-13	2
3	COVER	537543-1	1
4	WASHER 6,4 ZC DIN 126 ISO 7091	F81053-1	2
5	SCREW M6X12 SHCS ZC 8.8 DIN 912 ISO 4762	F81001-87	2
6	WASHER 8,2 ZC SPRING LOCK DIN 127	F81054-4	4
7	SCREW M8X20 SHCS ZC 8.8 DIN 912 ISO 4762	F81002-30	4
8	SAWDUST OUTLED HOSE, MASTER CLIP PUR DN100 L=800 [MM]	537389	1
9	WORM CLAMP 90-110	F81095-8	2



### 3.20 Spindle Moving Assembly

537025\_001\_EN\_A  
 537025\_MANUAL

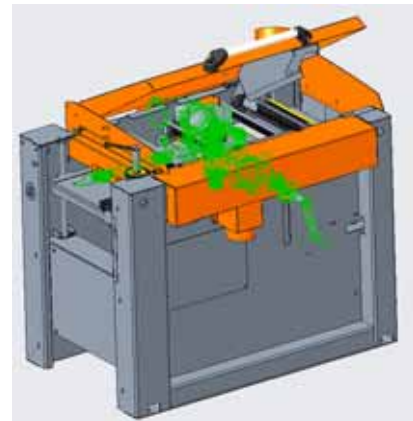
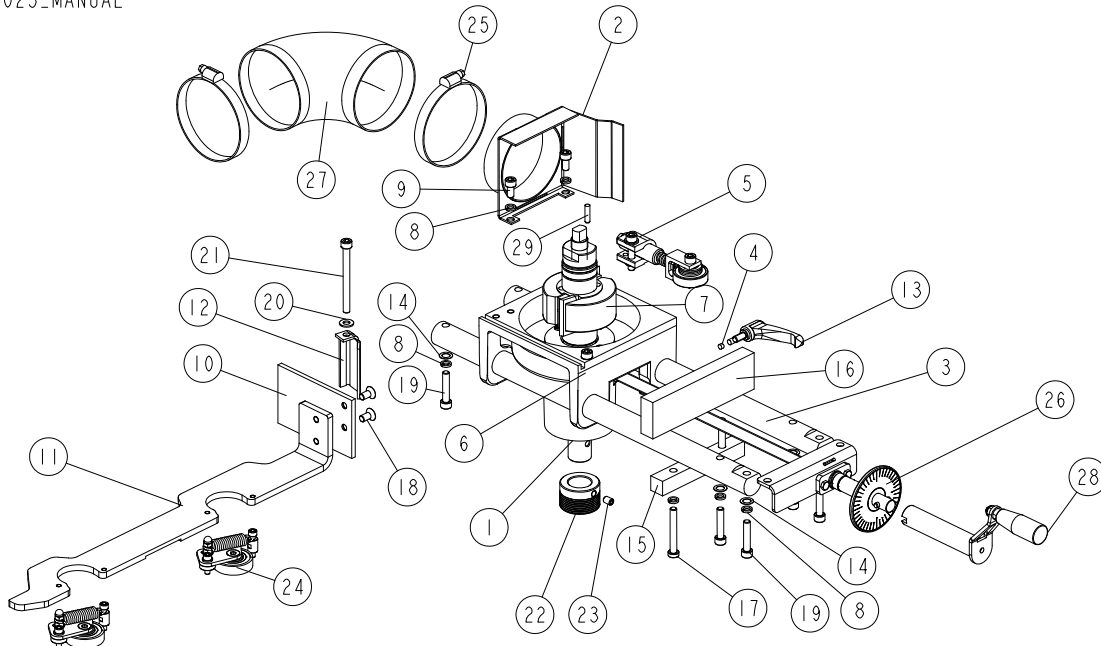

Ref	DESCRIPTION (* indicates parts available in assemblies only)	PART #	QTY
-	<b>SPINDLE MOVING ASSEMBLY</b>	537025	1
1	SPINDLE MOUNT BASE	546837-1	1
2	SAWDUST OUTLET WELDMENT	537028-1	1
3	LEFT SPINDLE GUIDE	537041	2
4	SLIDE	535987	2
5	CLAMP ROLLER ASSEMBLY II <a href="#">See Section 3.21</a>	533550	1
6	SCREW M8X35 SHCS ZC 8.8 DIN 912 ISO 4762	F81002-58	1
7	LEFT SPINDLE ASSEMBLY <a href="#">See Section 3.22</a>	537005	1
8	WASHER 8,2 ZC SPRING LOCK DIN 127	F81054-4	10
9	SCREW M8X16 SHCS ZC 8.8 DIN 912 ISO 4762	F81002-39	2
10	MOUNT PLATE	537027-1	1
11	BOARD GUIDE FENCE	537026-1	1
12	GUIDE MOUNT BRACKET	535984-1	1
13	ADJUSTABLE HANDLE ERZ.63 P-M8X16	535988	1

Ref	DESCRIPTION (* indicates parts available in assemblies only)	PART #	QTY	
14	THIN WASHER 10/16-0.5	535990	8	
15	GUIDE BLOCK 1	536956-1	1	
16	GUIDE BLOCK 2	536957-1	1	
17	SCREW M8X60 LHSCS 8.8 DIN 7984	F81002-41	2	
18	SCREW M8X16 HSFHS ZC 8.8 DIN7991 ISO10642	F81002-115	2	
19	SCREW M8X40 SHCS ZC 8.8 DIN 912 ISO 4762	F81002-29	6	
20	WASHER 8,4 ZC DIN 126 ISO 7091	F81054-1	1	
21	SCREW M8X90 SHCS ZC 8.8 DIN 912 ISO 4762	F81002-44	1	
22	PULLEY, MULTI-GROOVE SMALL ALUMINIUM	533586	1	
23	SCREW M8X12 HSS W/CONE POINT ZC 45H DIN 914	F81002-105	1	
24	CLAMP ROLLER COMPLETE <a href="#">See Section 3.23</a>	536980	2	
25	WORM CLAMP 90-110	F81095-8	2	
26	TRAPEZOIDAL SCREW ASSEMBLY <a href="#">See Section 3.24</a>	537042	1	
27	SAWDUST OUTLET HOSE MASTER CLIP PUR DN100 L=360 [MM]	537390	1	
28	HANDLE ASSEMBLY <a href="#">See Section 3.27</a>	537810	1	
29	DOWEL PIN 6M6X12 DIN 7 ISO 2338	F81045-5	1	

**3.21 Clamp Roller Assembly II**

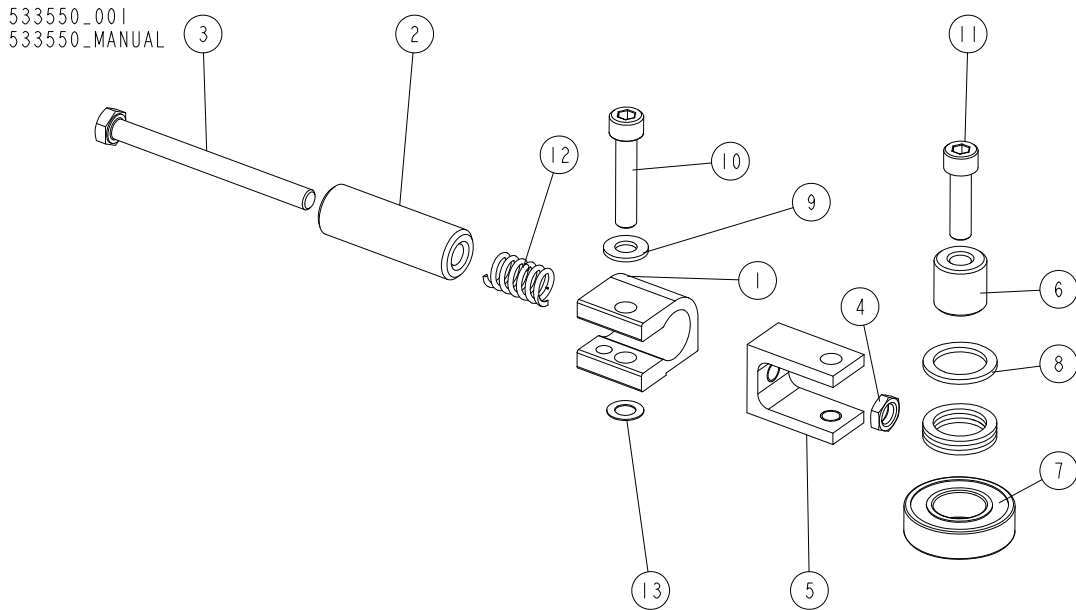

REF	DESCRIPTION (* indicates parts available in assemblies only)	PART #	QTY
-	<b>CLAMP ROLLER ASSEMBLY II</b>	533550	1
1	CONNECTOR, ALUMINIUM	533551-1	1
2	BUSHING, 8.5/20-60 ZINC-PLATED	533553-1	1
3	BOLT M8X90 HH ZC FT 8.8 DIN 933	F81002-16	1
4	NUT, M8-04-FE/ZN ISO4035 HEX THIN	F81032-8	1
5	CONNECTOR, ALUMINIUM	533552	1
6	BUSHING, 8.2/20-20	533554-1	1
7	BEARING, 6004 2RS CX ROLLING	093868	1
8	WASHER, 28/20-2	533555	4
9	WASHER 8,4 ZC DIN 126 ISO 7091	F81054-1	1
10	SCREW M8X40 SHCS ZC 8.8 DIN 912 ISO 4762	F81002-29	1
11	SCREW M8X30 SHCS ZC 8.8 DIN 912 ISO 4762	F81002-31	1
12	SPRING, 12X25XN2	533556	1
13	RING SHIM 14/8-05 DIN 988	F81055-16	1

### 3.22 Left Spindle

537005\_001\_EN  
537005\_MANUAL

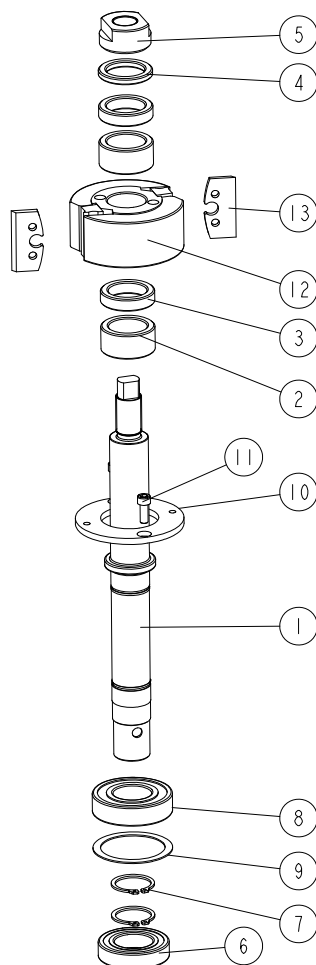

REF	DESCRIPTION (* indicates parts available in assemblies only)	PART #	QTY
-	<b>LEFT SPINDLE ASSEMBLY</b>	537005	1
1	SHAFT	533537	1
2	BUSHING, 30/42-20.2 ZINC-PLATED	533541-1	2
3	BUSHING, 30/42-10 ZINC-PLATED	533539-1	2
4	BUSHING, 30/42-5.2 ZINC-PLATED	533540-1	1
5	NUT, M20X1.5 LEFT	533538-1	1
6	BEARING, 6006 2RSR	096191	1
7	OUTSIDE RETAINING RING Z30 PN-M/85111 DIN 471	F81090-23	2
8	BEARING, 6206 2RSR P6 ROLLING (FAG, NSK, SKF)	100787	1
9	WASHER 50X61.6X1	533543	1
10	PLATE, CLAMPING	533542-1	1
11	SCREW M6X16 SHCS ZC 8.8 DIN 912 ISO 4762	F81001-21	2
-	CUTTERHEAD, TB90-92 STEEL	240-010	1
12	CUTTERHEAD	533587	1
13	KNIFE, CUTTER	533588	2

### 3.23 Clamp Roller Assembly

536980\_001  
536980\_MANUAL

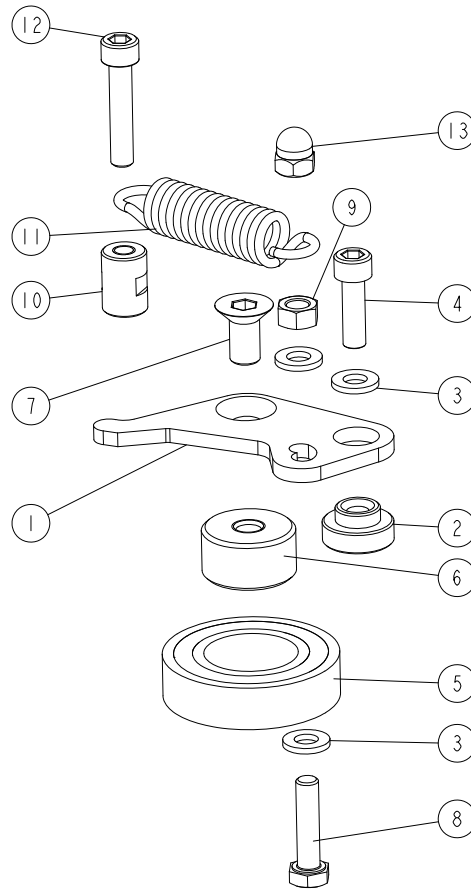

REF	DESCRIPTION (* indicates parts available in assemblies only)	PART #	QTY
-	<b>CLAMP ROLLER ASSEMBLY</b>	536980	1
1	BRACKET, BEARING MOVABLE	533525-1	1
2	BUSHING, 6.2/12-10 FLANGED 19-6	533632	1
3	WASHER 6.4 ZC DIN 126 ISO 7091	F81053-1	3
4	SCREW M6X20 SHCS ZC 8.8 DIN 912 ISO 4762	F81001-22	1
5	BEARING 6005 2RS	089652	1
6	BUSHING, M8/25-13.5 ZINC-PLATED	533529-1	1
7	SCREW M8X16 HSFHS ZC 10.9 DIN7991 ISO 10642	F81002-82	1
8	BOLT M6X25 HH ZC FT 8.8 DIN 933	F81001-3	1
9	NUT M6 ZC 8 DIN 934	F81031-1	1
10	BUSHING, M6/12-17 ZINC-PLATED	533633-1	1
11	SPRING, 15X65X2.5	533571	1
12	SCREW M6X30 SHCS ZC 8.8 DIN 912 ISO 4762	F81001-42	1
13	HEX DOMED CAP NUT M6 ZC 6 DIN 1587	F81032-20	1

### 3.24 Trapezoidal Screw

537042\_001\_EN\_A  
537042\_MANUAL

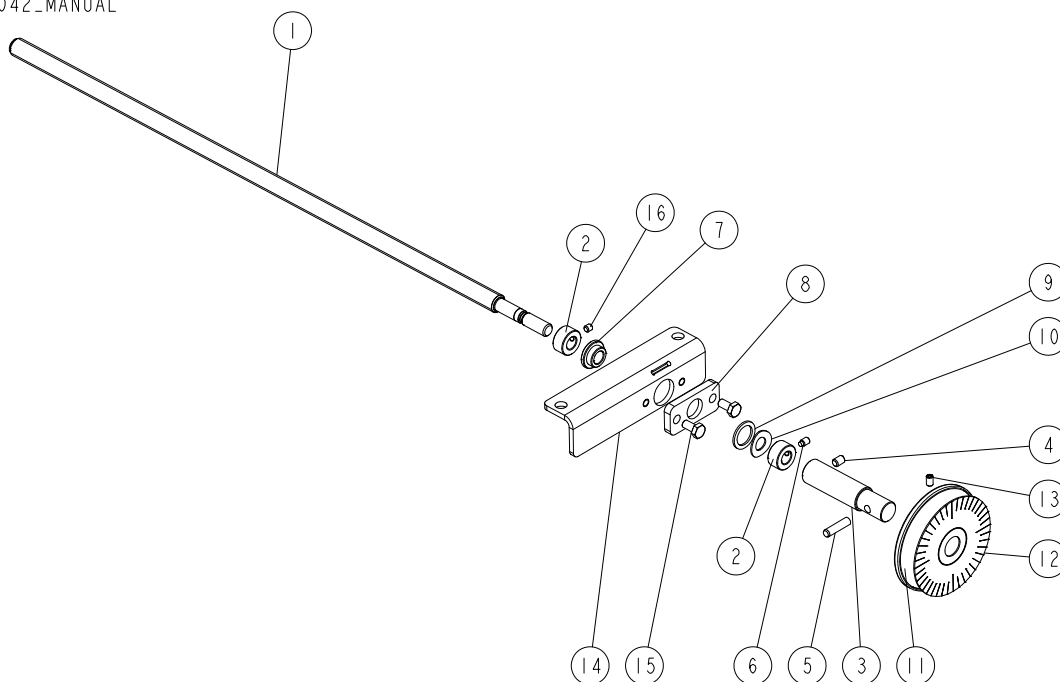

Ref	DESCRIPTION (* indicates parts available in assemblies only)	PART #	QTY
-	<b>TRAPEZOIDAL SCREW ASSEMBLY</b>	537042	1
1	CUTTER TRAPEZOIDAL SCREW	535996	1
2	CONNECTOR 1	535997-1	2
3	CONNECTOR 2	537044-1	1
4	SCREW M6X8 45H HSS W/FLAT POINT ZC DIN913 ISO4026	F81013-1	1
5	DOWEL PIN 6M6X12 DIN 7 ISO 2338	F81045-5	1
6	SCREW M5X8 45H HSS W/DOG POINT ZC DIN 915 ISO4028	F81014-15	1
7	SELF LUBRICATING BEARING, AMES N10/N16/N22-8	541372	1
8	SLIDE BUSHING PLATE	535991-1	1
9	SPACER 16/22-1.5 DIN 988	F81055-19	1
10	DIN 137 B WAVE SPRING WASHER 10.5	F81055-18	1
11	DISK, ROUND SCALE	533594	1
12	DECAL, MP200 ROUND SCALE	533577	1
13	SCREW WITHOUT HEAD M5X8 45H DIN 913	F81014-7	1
14	SCREW MOUNTING PLATE	537045-1	1
15	BOLT M6X12 HH ZC FT 8.8 DIN 933	F81001-7	2
16	SCREW M5X5 45H W/FLAT POINT ZC DIN 913 ISO 4026	F81014-14	1

### 3.25 Up/Down Assembly

537046\_001\_A  
537046\_MANUAL

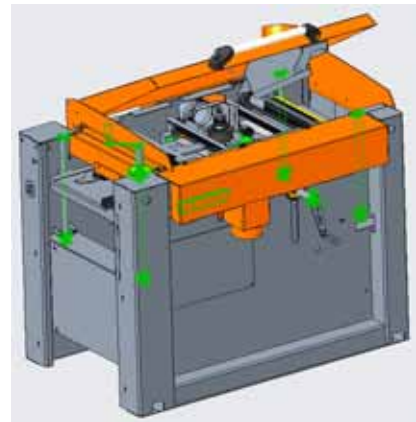
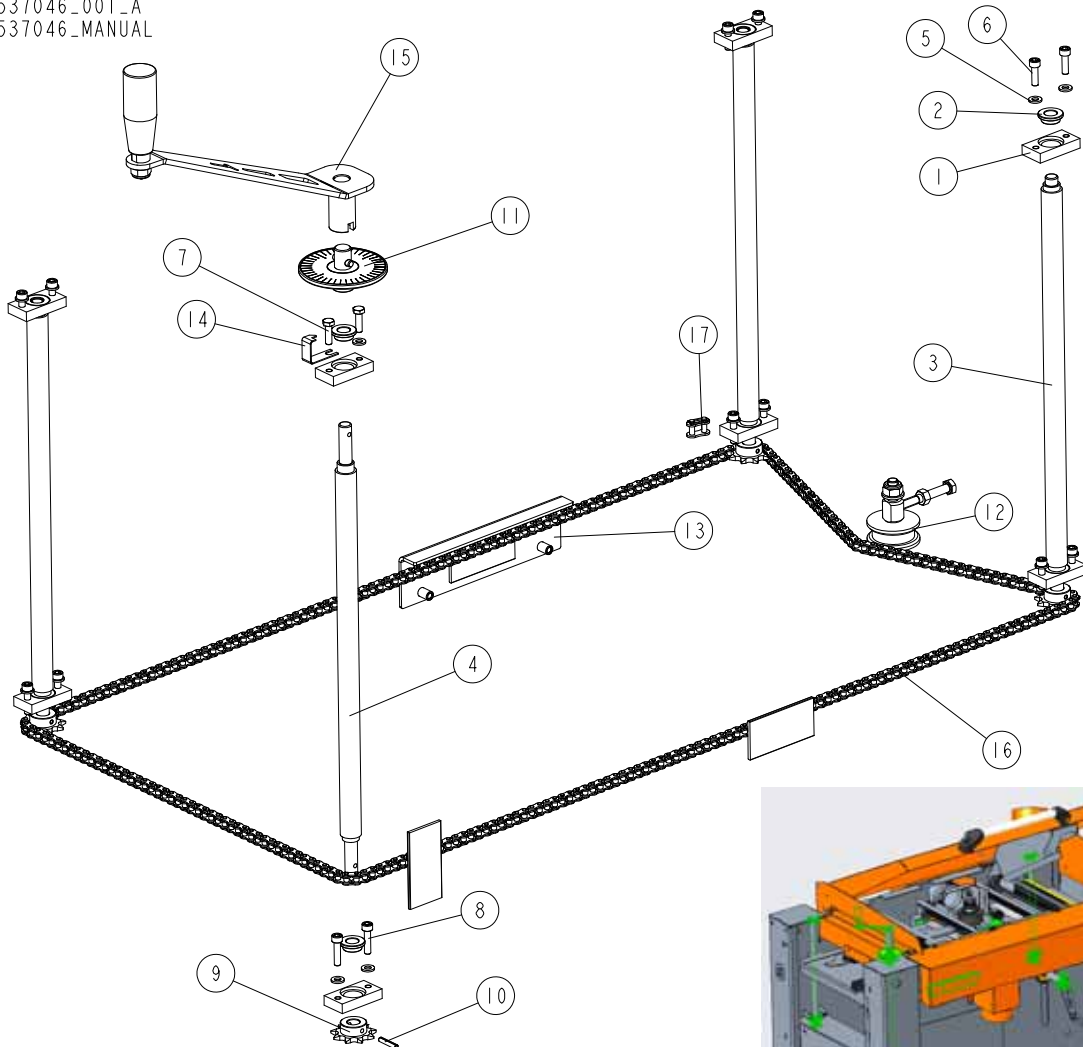

Ref	DESCRIPTION (* indicates parts available in assemblies only)	PART #	QTY
-	<b>UP/DOWN ASSEMBLY</b>	537046	1
1	BLOCK	533113-1	8
2	BUSHING, 12/18-8 FLANGED 24-3	546901	8
3	TRAPEZOIDAL SCREW, TR20X4 ACME	533116	3
4	ADJUSTABLE TRAPEZOIDAL SCREW, TR20X4 ACME	537047	1
5	WASHER 6,4 ZC DIN 126 ISO 7091	F81053-1	15
6	SCREW M6X20 SHCS ZC 8.8 DIN 912 ISO 4762	F81001-22	6
7	BOLT M6X20 HH ZC FT 8.8 DIN 933	F81001-2	2
8	BOLT M6X25 SHCS ZC PT 8.8 DIN 912 ISO 4762	F81001-41	8
9	SPROCKET, Z=9; 1/2"X 3/16"(CHAIN 083-1)	533111	4
10	PIN SPRING 4X24 ZC DIN 1481 ISO 8752	F81044-13	4
11	SCALE, ROUND COMPLETE <a href="#">See Section 3.26</a>	533676	1

# 3 MECHANICAL ASSEMBLY

## Up/Down Assembly

---

Ref	DESCRIPTION (* indicates parts available in assemblies only)	PART #	QTY	
12	CHAIN TENSION, ASSEMBLY <a href="#">See Section 3.29</a>	534390	1	
13	CHAIN SLIDE ASSEMBLY <a href="#">See Section 3.30</a>	537560	1	
14	INDICATOR, SCALE	537558	1	
15	HANDLE ASSEMBLY <a href="#">See Section 3.28</a>	535975	1	
16	CHAIN 083-1; P = 1/2 "; LENGT L = 2,7559 M (217 LINKS +1 HALF-LINK)	537050	1	
17	CONNECTING LINK FOR CHAIN 083-1	533128	1	



### 3.26 Scale

533676\_001\_A  
533676\_MANUAL

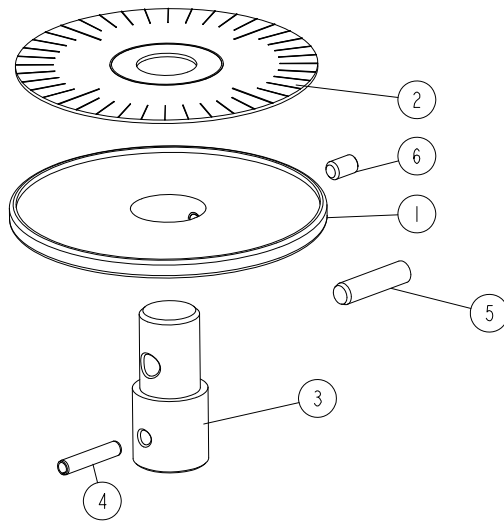

REF	DESCRIPTION (* indicates parts available in assemblies only)	PART #	QTY	
-	<b>SCALE, ROUND COMPLETE</b>	533676	1	
1	DISK, ROUND SCALE	533594	1	
2	DECAL, MP200 ROUND SCALE	533577	1	
3	PIN, SCALE DISK MOUNT	533595-1	1	
4	COILED SPRING PIN 4X20, ISO 8752, STEEL.	F81044-11	1	
5	DOWEL PIN 6M6X12 DIN 7 ISO 2338	F81045-5	1	
6	SCREW WITHOUT HEAD M5X8 45H DIN 913	F81014-7	1	

### 3.27 Handle

537810-001  
537810\_MANUAL

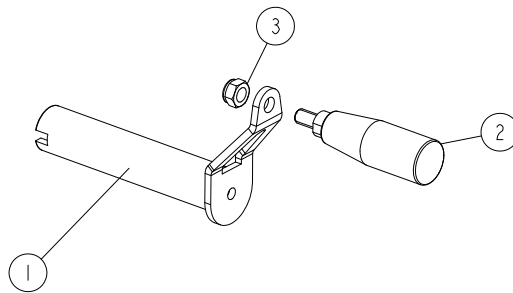

Ref	DESCRIPTION (* indicates parts available in assemblies only)	PART #	QTY	
-	<b>HANDLE ASSEMBLY</b>	537810	1	
1	HANDLE WELDMENT	537811-1	1	
2	REVOLVING GRIP	533505	1	
3	NUT M8 ZC 8 NYLOCK DIN 982 ISO 7040	F81032-2	1	

### 3.28 Handle

535975\_001\_EN  
 535975\_MANUAL

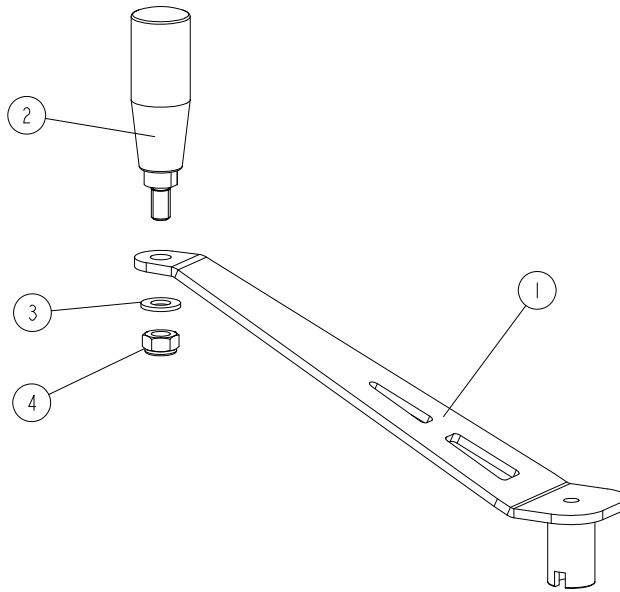

Ref	DESCRIPTION (* indicates parts available in assemblies only)	PART #	QTY	
-	<b>HANDLE ASSEMBLY</b>	535975	1	
1	HANDLE WELDMENT	535973-1	1	
2	REVOLVING GRIP	535974	1	
3	WASHER 10,5 ZC DIN 126 ISO 7091	F81055-1	1	
4	NUT M10 ZC 8 NYLOCK DIN 982 ISO 7040	F81033-1	1	

### 3.29 Chain Tension

534390\_001  
534390\_MANUAL

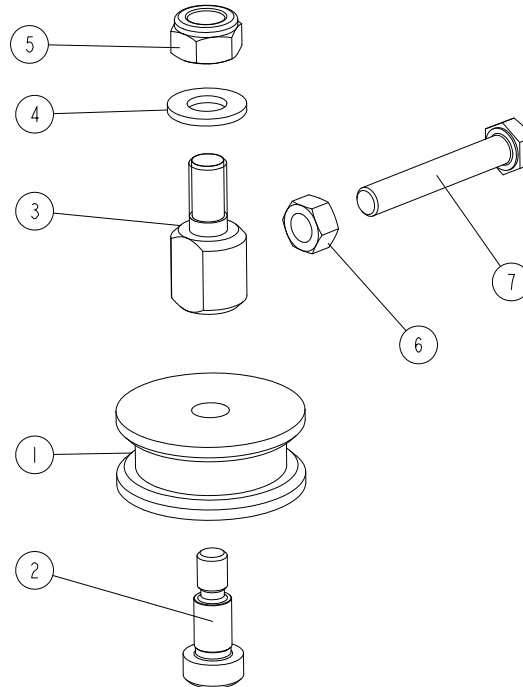

Ref	DESCRIPTION (* indicates parts available in assemblies only)	PART #	QTY	
-	<b>CHAIN TENSION, ASSEMBLY</b>	534390	1	
1	ROLLER, TENSIONER	533576	1	
2	SHOULDER SCREW HSH -10-M8-16; 12,9	F81003-139	1	
3	BOLT, MOUNTING	534388-1	1	
4	WASHER 10,5 ZC DIN 126 ISO 7091	F81055-1	1	
5	NUT M10 ZC 8 NYLOCK DIN 982 ISO 7040	F81033-1	1	
6	NUT M8 ZC 8 DIN 934	F81032-1	1	
7	SCREW M8X60 HH ZC 8.8 PT DIN 931	F81002-54	1	

### 3.30 Chain Slide

537560\_001\_EN\_A  
537560\_MANUAL

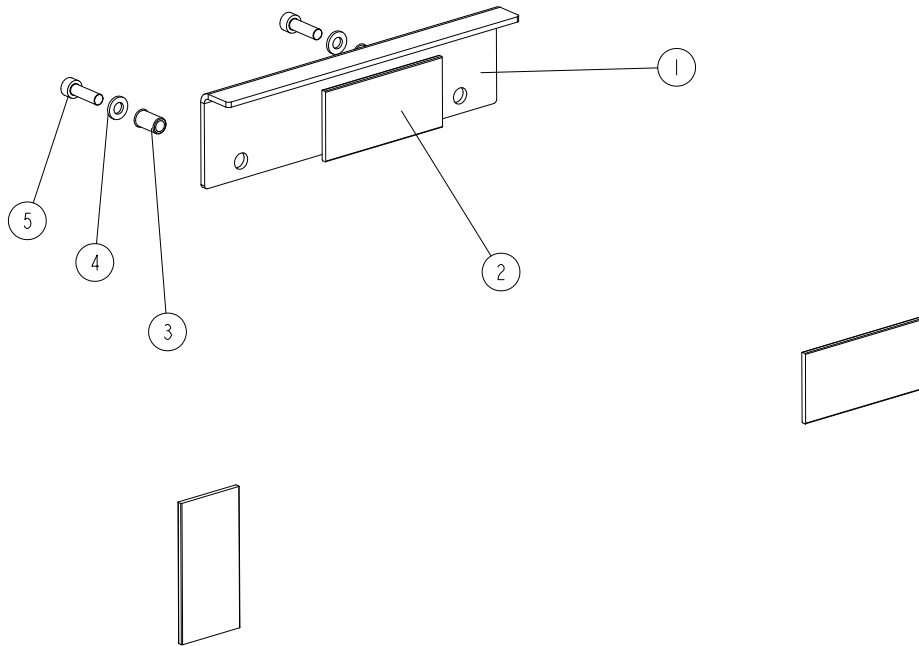

REF	DESCRIPTION (* indicates parts available in assemblies only)	PART #	QTY	
-	<b>CHAIN SLIDE ASSEMBLY</b>	537560	1	
1	ANGLE SECTION	537561-1	1	
2	SLIDE TAPE	537562	1	
3	RIVET NUT M6 1.5-4.0 W/ COUNTERSUNK HEAD AND KNURLED SHANK	F81031-13	2	
4	WASHER 6,4 ZC DIN 126 ISO 7091	F81053-1	2	
5	SCREW M6X20 SHCS ZC 8.8 DIN 912 ISO 4762	F81001-22	2	

### 3.31 Rod Set

537580\_001\_EN  
537580\_MANUAL

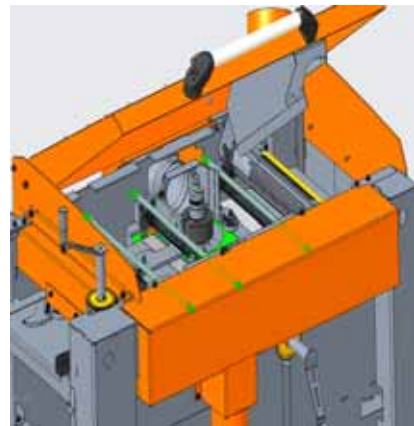
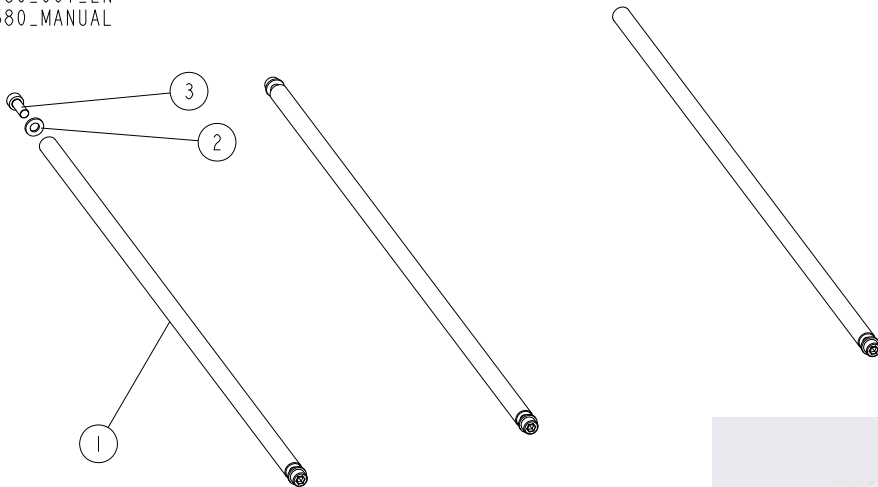

REF	DESCRIPTION (* indicates parts available in assemblies only)	PART #	QTY	
-	<b>ROD SET</b>	537580	1	
1	SHAFT	533092-1	3	
2	WASHER 6,4 ZC DIN 126 ISO 7091	F81053-1	5	
3	SCREW M6X16 SHCS ZC 8.8 DIN 912 ISO 4762	F81001-21	5	

### 3.32 Moving Plate

537584\_001\_EN  
 537584\_MANUAL

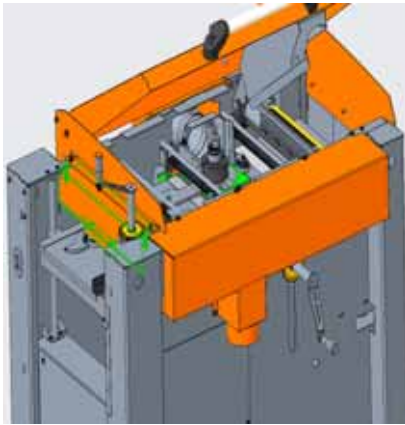
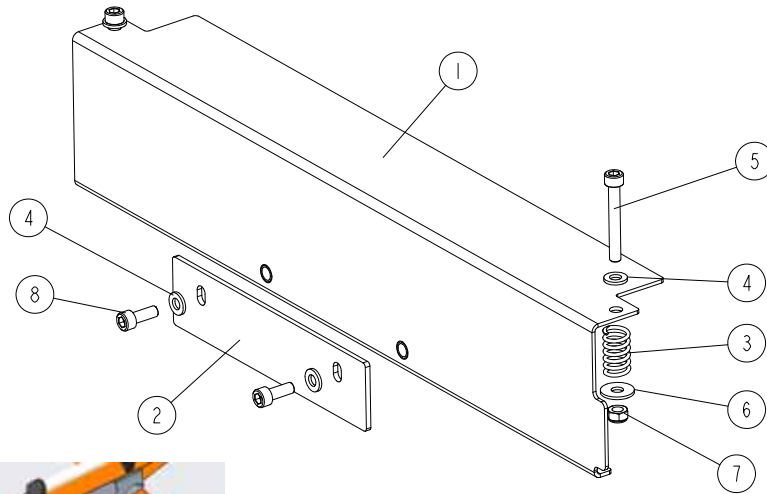

REF	DESCRIPTION (* indicates parts available in assemblies only)	PART #	QTY	
-	<b>MOVING PLATE ASSEMBLY</b>	537584	1	
1	MOVING PLATE	537583	1	
2	PLATE	537582-1	1	
3	SPRING	533677	2	
4	WASHER 6,4 ZC DIN 126 ISO 7091	F81053-1	4	
5	SCREW M6X45 SHC ZC 8.8 DIN 912 ISO 4762	F81001-86	2	
6	WASHER 6,5 ZC FENDER DIN 9021 ISO 7093	F81053-11	2	
7	NUT M6 ZC 8 NYLOCK DIN 982 ISO 7040	F81031-2	2	
8	SCREW M6X16 SHCS ZC 8.8 DIN 912 ISO 4762	F81001-21	2	

**3.33 V-belt Cover (No. 537566)**

537566\_001\_A\_EN  
537566\_MANUAL

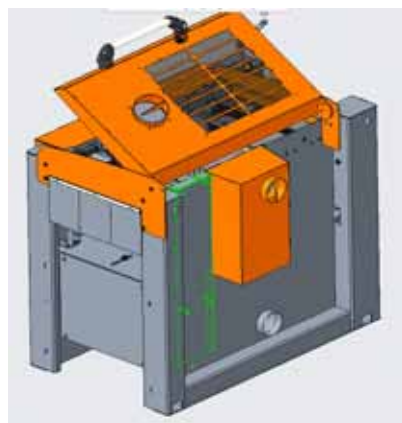
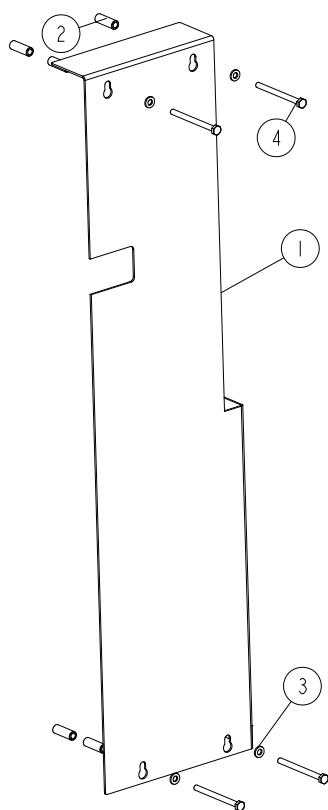

REF	DESCRIPTION (u indicates parts available in assemblies only)	PART #	QTY	
-	<b>V-BELT COVER</b>	537566	1	
1	SIDE PLATE	537540-1	1	
2	BUSHING 6.2/10-30	547036	8	
3	WASHER, 6.4 FLAT ZINC	F81053-1	4	
4	BOLT M6X75 8.8 FE/ZN5 PN-85/M-82105	F81001-125	4	

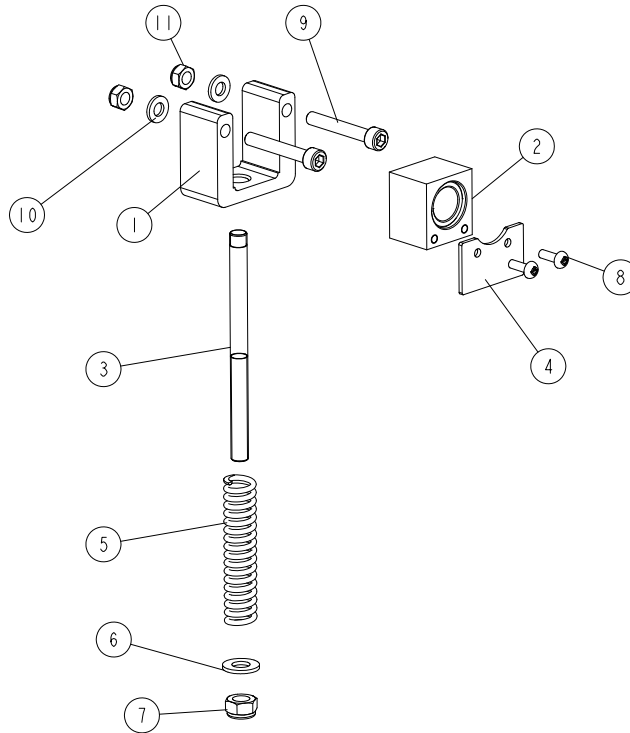

## 3.34 Slide Bearing Assembly (No. 533520)

533520\_001\_B  
533520\_MANUAL

REF	DESCRIPTION (◆ indicates parts available in assemblies only)	PART #	QTY
-	BEARING ASSEMBLY, SLIDE	533520	1
1	HOUSING, SLIDE BEARING	533514	1
2	SLIDE BLOCK ASSEMBLY	537575	1
3	ROD, SHAFT TENSION	546898-1	1
4	COVER, RUBBER	533516	1
5	SPRING	533519-1	1
6	WASHER, 8.4 FLAT,ZINC	F81054-1	1
7	NUT, M8-8-B HEX NYLON ZINC LOCK	F81032-2	1
8	SCREW M4X12 PHILLIPS ZC 5.8 DIN 7985	F81011-43	2
9	BOLT M6X40 HEX	F81001-124	2
10	WASHER, M6, FLAT,ZINC	F81053-1	2
11	NUT, M6-8-B HEX NYLON ZINC LOCK	F81031-2	2

**3.35 Feed Roller Set (No. 546806)**

546806\_001  
546806\_MANUAL

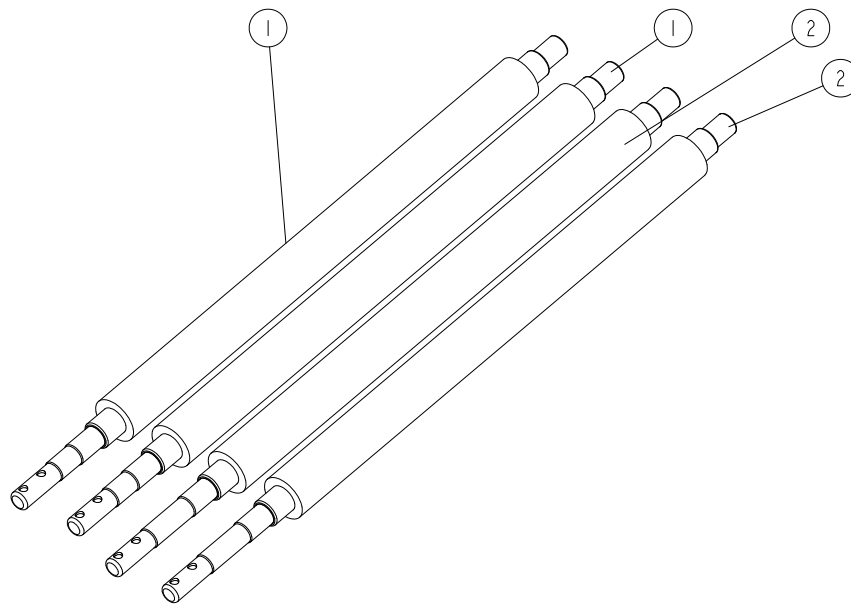

REF.	DESCRIPTION (* indicates parts available in assemblies only)	PART #	QTY
-	<b>ROLLER SET, FEED</b>	546806	1
1	ROLLER W/POLYURETHANE COATING (2)	541441	2
2	ROLLER W/POLYURETHANE COATING (1)	541442	2

### 3.36 Feed Roller Set (No. 546807)

546807\_001  
546807\_MANUAL

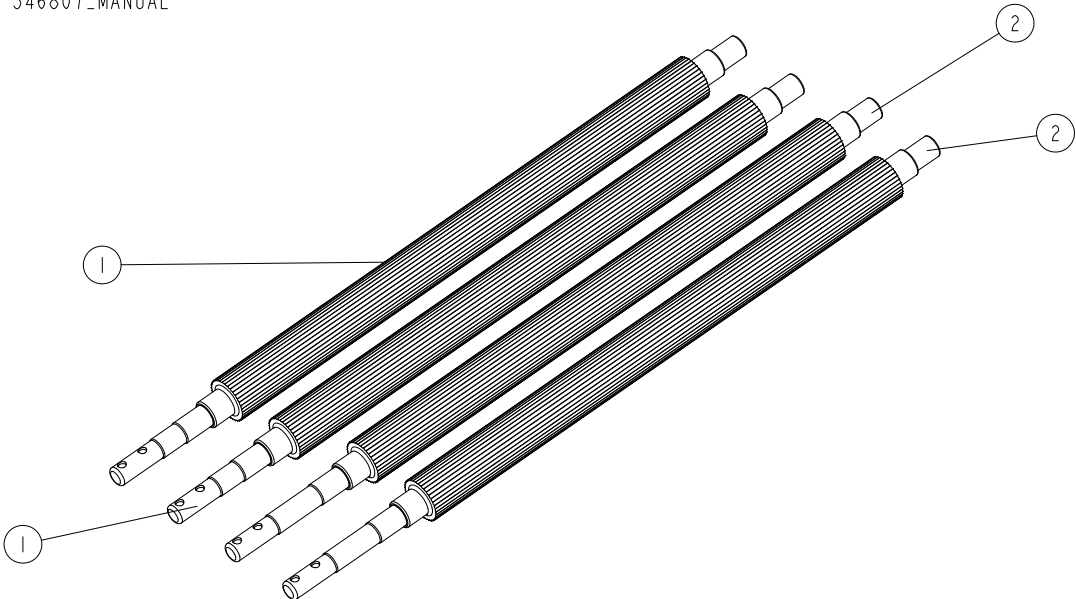

REF.	DESCRIPTION (* indicates parts available in assemblies only)	PART #	QTY	
-	<b>ROLLER SET, HARDENED STEEL FEED</b>	546807	1	
1	ROLLER, STEEL FEED	542451-1	2	
2	ROLLER, STEEL FEED	542452-1	2	

## 3.37 Guide Adjustment Tool (No. 568542) - optional equipment

568542\_001  
568542\_MANUAL

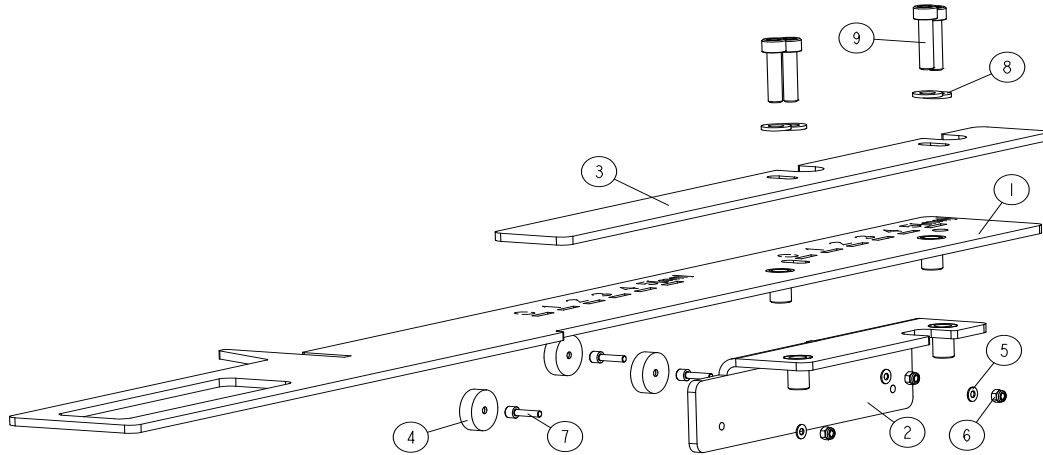

REF	DESCRIPTION (* indicates parts available in assemblies only)	PART #	QTY
-	<b>MP260 GUIDE ADJUSTMENT TOOL</b>	568542	1
	<b>MP260 GUIDE ADJUSTMENT TOOL - AMERICAN VERSION</b>	568542-US	1
1	PLATE, ADJUSTMENT TOOL	568539	1
	PLATE, ADJUSTMENT TOOL - AMERICAN VERSION	568539-US	1
2	BRACKET, MAGNET MOUNT	568540-1	1
3	ADJUSTMENT PLATE	568541	1
4	BRACKET, MAGNETIC UM 20 25 X 7 X 4 X 7 / F	577458	3
5	WASHER, 3.2-LAT ZINC	F81050-2	3
6	NUT, M3-6-HEX NYLON ZINC LOCK	F81028-2	3
7	SCREW, M3X12-8.8 PN-EN ISO 4762 HEX SOCK	F81011-30	3
8	WASHER, 6.4 FLAT ZINC	F81053-1	4
9	BOLT, M6X25 SHCS ZC PT 8.8 DIN 912 ISO 47	F81001-41	4



### 3.38 Outfeed Guide Fence Assembly, MP260 (No. 564989) - additional equipment

564989\_001  
564989\_MANUAL

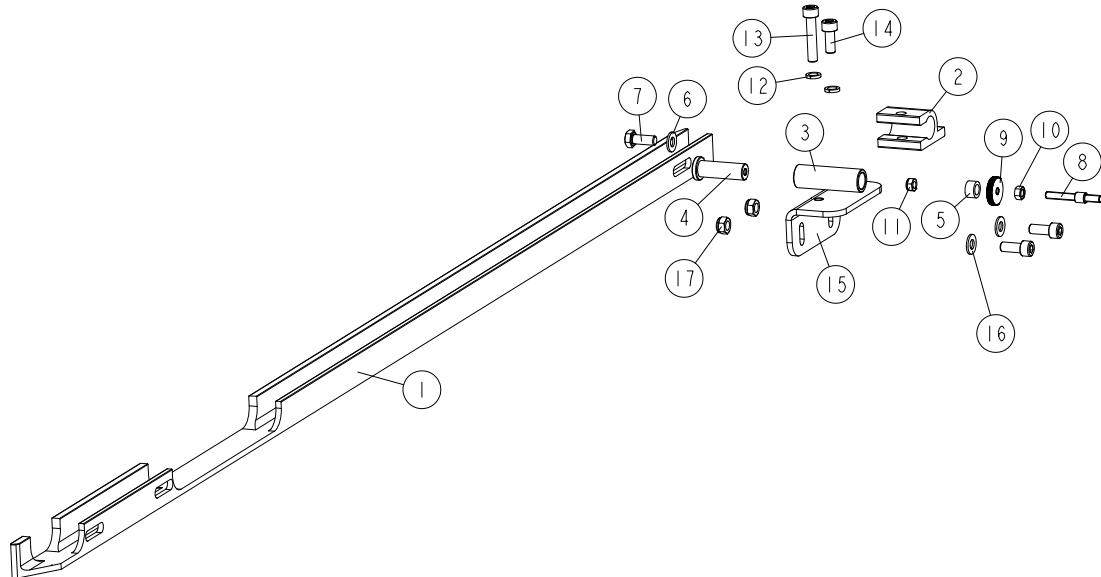

REF.	DESCRIPTION (* indicates parts available in assemblies only)	PART #	QTY
-	<b>OUTFEED GUIDE FENCE ASSEMBLY, MP260</b>	564989	1
1	GUIDE FENCE, OUTFEED 1400MM MP260	564988-1	1
-	ADJUSTMENT KIT, GUIDE FENCE	562133	1
2	CLAMP	536966-1	1
-	ADJUSTABLE KNOB	536965	1
3	PIN GUIDE	537001-1	1
4	KNOB PIN	536999-1	1
5	INSERT	537002	1
6	WASHER, 8.4 FLAT ZINC	F81054-1	1
7	BOLT, M8X20 8.8 HEX HEAD FULL THREAD ZINC	F81002-4	1
8	THREAD PIN M6	541455	1
9	KNURLED NUT	541454	1
10	NUT, M6 8 HEX ZINC	F81031-1	1
11	NUT, M6-8-B HEX NYLON ZINC LOCK	F81031-2	1
12	WASHER 8,2 SPLIT LOCK ZINC	F81054-4	2
13	SCREW, M8X40-8.8 HEX SOCKET HEAD CAP ZIN	F81002-29	1
14	SCREW, M8X20-8.8 HEX SOCKET HEAD CAP ZIN	F81002-30	3
15	BRACKET	562136-1	1
16	WASHER, 8.4 FLAT ZINC	F81054-1	2
17	NUT, M8-8-B HEX NYLON ZINC LOCK	F81032-2	2

## SECTION 4 MOTOR KITS

### 4.1 Motor Kit for MP260 EH 3x400V CE

537021\_001\_EN\_A  
537021\_MANUAL

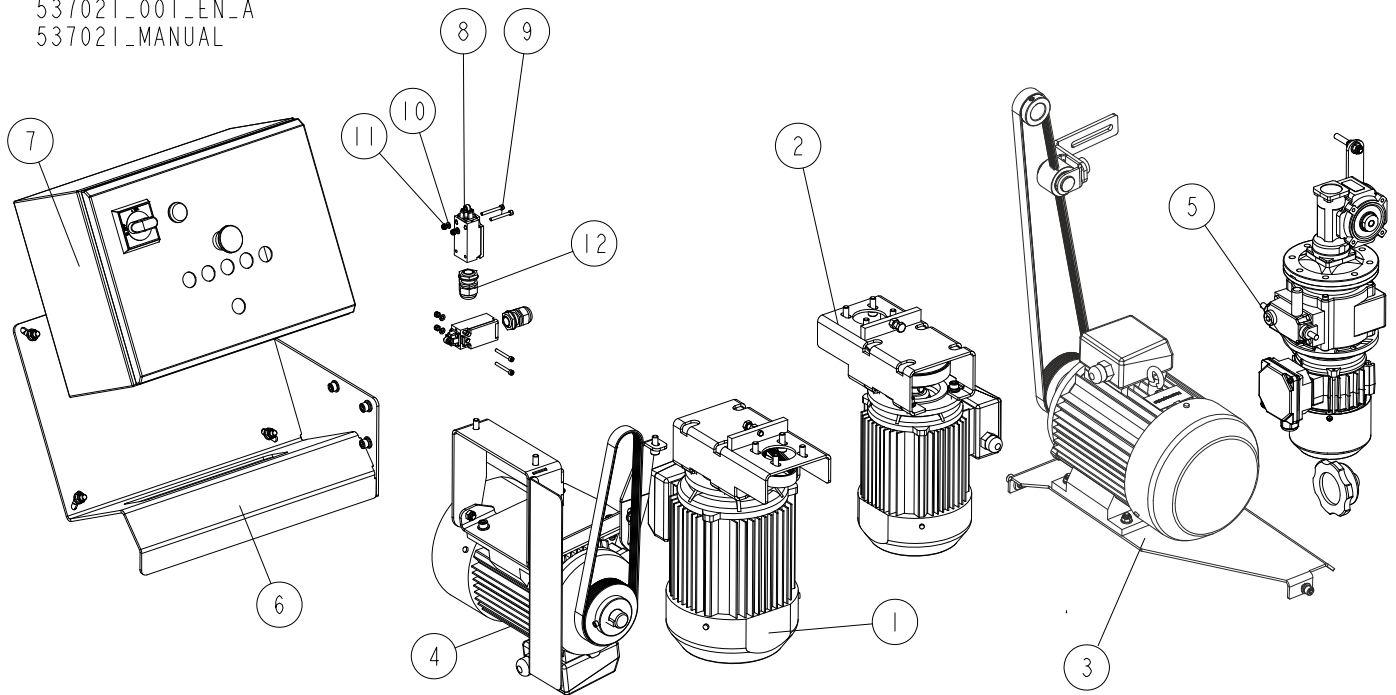

REF	DESCRIPTION (* indicates parts available in assemblies only)	PART #	QTY
-	PRO MOTOR KIT FOR MP260EH 3x400V CE	537021	1
	PRO MOTOR KIT FOR MP260EB3x230V CE	537021-2	1
-	ECO MOTOR KIT FOR MP260EH 3x400V CE	537020	1
	ECO MOTOR KIT FOR MP260EB 3x230V CE	537020-2	1
1	SIDE CUTTER DRIVE <a href="#">See Section 4.2</a>	533647	1
2	SIDE CUTTER DRIVE (SLIDING) <a href="#">See Section 4.2</a>	541459	1
3	HORIZONTAL UPPER CUTTER PRO DRIVE <a href="#">See Section 4.3</a>	537035	1
4	HORIZONTAL BOTTOM CUTTER DRIVE <a href="#">See Section 4.4</a>	537031	1
5	MP260 PRO FEED DRIVE <a href="#">See Section 4.5</a>	537036	1
6	ELECTRIC BOX BRACKET-COMPLETE <a href="#">See Section 4.6</a>	537032	1
7	ELECTRICAL BOX MP260 3X400V CE COMPLETE <a href="#">See Section 4.7</a>	532791	1
8	SAFETY SWITCH D4N-4132	537641	2
9	BOLT M4X35 SHCS ZC PT 8.8 DIN 912 ISO 4762	F81011-34	4
10	WASHER 4,3 ZC DIN 126 ISO 7091	F81051-2	4
11	NUT M4 ZC 8 NYLOCK DIN 982 ISO 7040	F81029-1	4
12	ELECTRICAL GLAND 20 HML	F81096-41	2

## 4.2 Side Cutter Drive

533647\_001\_B  
533647\_MANUAL

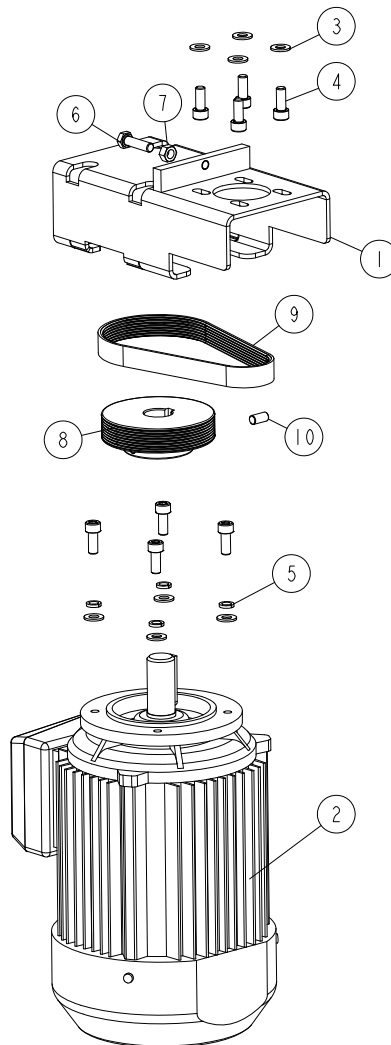

REF.	DESCRIPTION (* indicates parts available in assemblies only)	PART #	QTY
-	<b>SIDE CUTTER DRIVE</b>	533647	1
-	<b>SIDE CUTTER DRIVE (SLIDING)</b>	541459	1
1	PLATE WELDMENT, MOTOR MOUNT	533649-1	1
2	MOTOR, INDUKTA 3SIEK90L2A 3KW IMV19	537385 <sup>1</sup>	1
	MOTOR, 3SIEK90L2A IMV19/C140 (3kW; 2860 r.p.m.)	533646 <sup>2</sup>	1
3	WASHER 8.4 ZC DIN 126 ISO 7091	F81054-1	8
4	SCREW M8X20 SHCS ZC 8.8 DIN 912 ISO 4762	F81002-30	8
5	WASHER 8.2 ZC SPRING LOCK DIN 127	F81054-4	4
6	BOLT M8X30 HH ZC FT 8.8 DIN 933	F81002-7	1
7	NUT M8 ZC 8 DIN 934	F81032-1	1
8	PULLEY, MULTI-GROOVE ALUMINIUM	533585	1
9	SCREW M8X16 HSS W/FLAT POINT ZC 45H DIN	F81002-124	1
10	BELT, 8 PJ 457 MULTI-RIBBED	533680	1

<sup>1</sup> Belongs to 533647

<sup>2</sup> Belongs to 541459



### 4.3 Horizontal Upper Cutter Drive

537035\_001\_EN\_D  
537035\_MANUAL

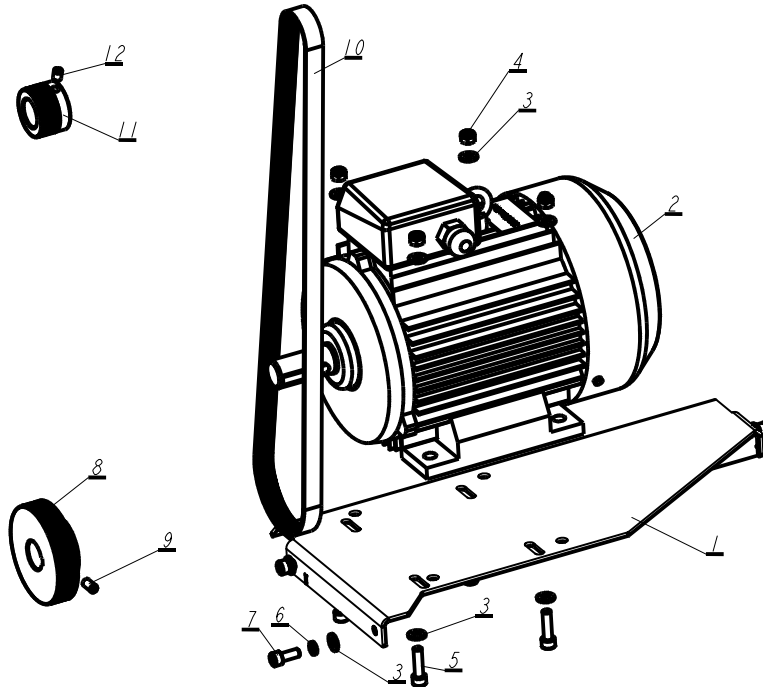

REF.	DESCRIPTION (* indicates parts available in assemblies only)	PART #	QTY
-	<b>HORIZONTAL UPPER CUTTER PRO DRIVE</b>	537035	1
1	MOTOR PLATE WELDMENT	535895-1	1
2	MOTOR 3SIE100L2A, 4KW, 2900 R.P.M, 50HZ	537387	1
3	WASHER 8,4 ZC DIN 126 ISO 7091	F81054-1	11
4	NUT M8 ZC 8 NYLOCK DIN 982 ISO 7040	F81032-2	4
5	SCREW M8X30 SHCS ZC 8.8 DIN 912 ISO 4762	F81002-31	4
6	WASHER 8,2 ZC SPRING LOCK DIN 127	F81054-4	3
7	SCREW M8X20 SHCS ZC 8.8 DIN 912 ISO 4762	F81002-30	3
8	PULLEY, MULTI-GROOVE ALUMINIUM MP200 PRO	533585-P	1
9	SCREW M8X16 HSS W/FLAT POINT ZC 45H DIN	F81002-124	1
10	BELT, 1301 PJ8 MULTI-RIBBED	564993	1
11	PULLEY, MULTI-GROOVE SMALL ALUMINIUM	533586	1
12	SCREW M8X12 HSS W/CONE POINT ZC 45H DIN 914	F81002-105	1

## 4.4 Horizontal Bottom Cutter Drive

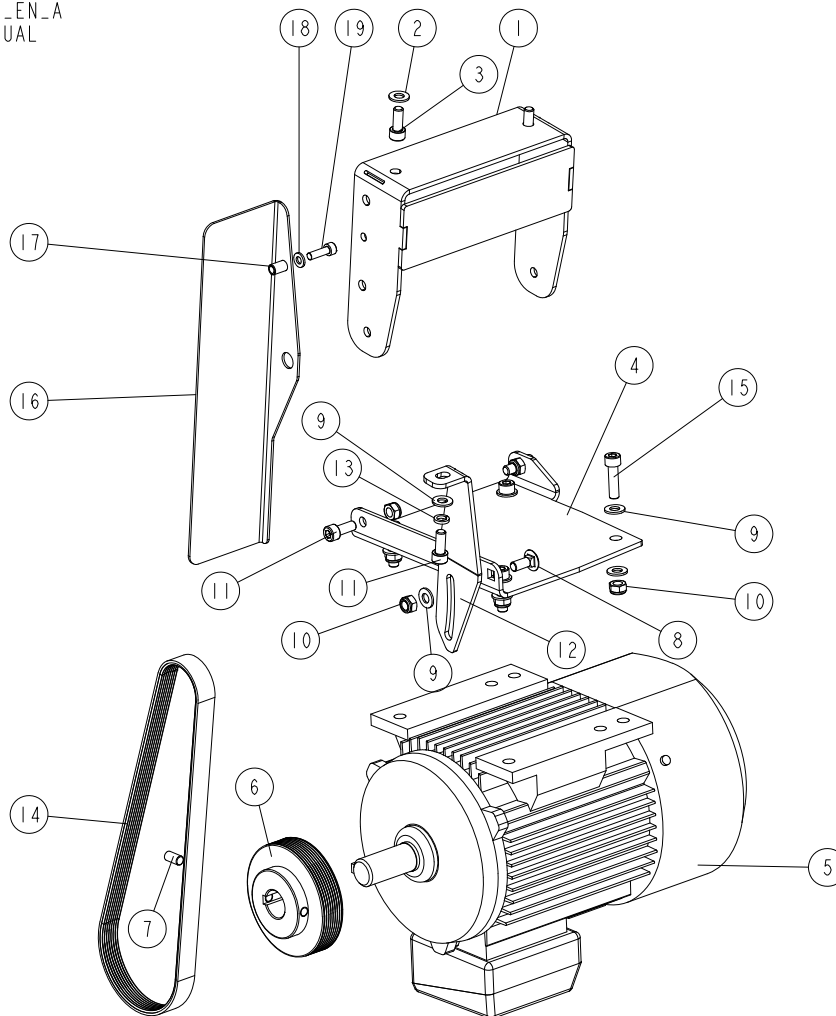
537031\_001\_EN\_A  
537031\_MANUAL

REF	DESCRIPTION (* indicates parts available in assemblies only)	PART #	QTY
-	<b>HORIZONTAL BOTTOM CUTTER DRIVE</b>	537031	1
-	MOTOR MOUNT ASSEMBLY	537539	1
1	MOTOR MOUNT WELDMENT	537538-1	1
2	WASHER 8,4 ZC DIN 126 ISO 7091	F81054-1	2
3	SCREW M8X20 SHCS ZC 8.8 DIN 912 ISO 4762	F81002-30	2
4	MOTOR PLATE	537023-1	1
5	MOTOR 3SIE90L2A, 3KW, 2900 R.P.M, 50HZ	537386	1
6	PULLEY, MULTI-GROOVE ALUMINIUM	533585	1
7	SCREW M8X16 HSS W/FLAT POINT ZC 45H DIN	F81002-124	1
8	BOLT M8X20 CARRIAGE ZC 8.8 DIN 603 ISO 8677	F81002-11	1
9	WASHER 8,4 ZC DIN 126 ISO 7091	F81054-1	10
10	NUT M8 ZC 8 NYLOCK DIN 982 ISO 7040	F81032-2	7
11	SCREW M8X20 SHCS ZC 8.8 DIN 912 ISO 4762	F81002-30	3
12	MOUNTING BRACKET	537024-1	1
13	WASHER 8,2 ZC SPRING LOCK DIN 127	F81054-4	1

REF	DESCRIPTION (* indicates parts available in assemblies only)	PART #	QTY	
14	BELT MULTI-RIBBED 8 PJ762	535803	1	
15	SCREW M8X30 SHCS ZC 8.8 DIN 912 ISO 4762	F81002-31	4	
-	BELT GUARD ASSEMBLY	537565	1	
16	GUARD PLATE	537564-1	1	
17	RIVET NUT M6 1.5-4.0 W/ COUNTERSUNK HEAD AND KNURLED SHANK	F81031-13	1	
18	WASHER 6,4 ZC DIN 126 ISO 7091	F81053-1	1	
19	SCREW M6X20 SHCS ZC 8.8 DIN 912 ISO 4762	F81001-22	1	

## 4.5 Feed Drive

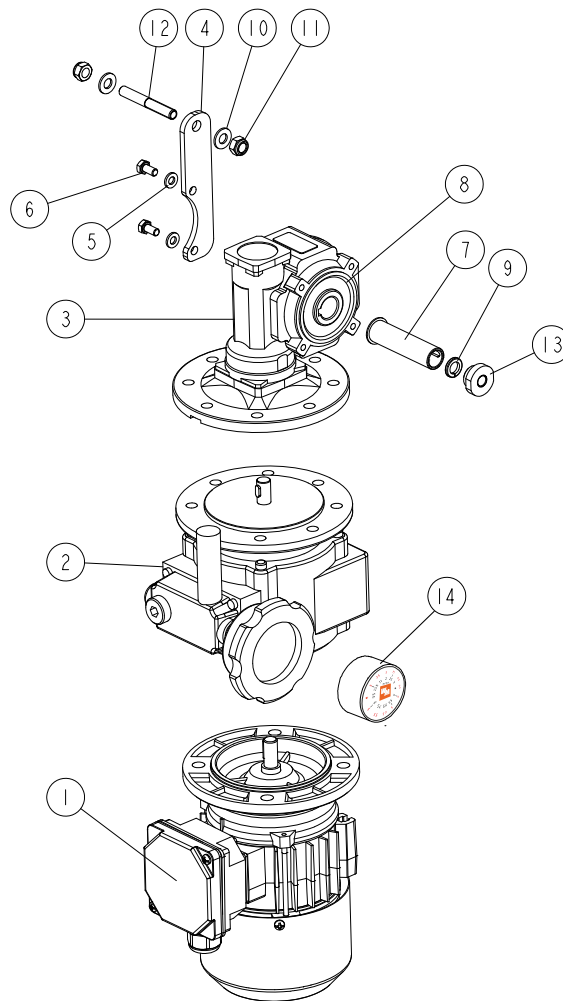
537036\_001\_EN\_B  
537036\_MANUAL

Ref.	DESCRIPTION (* indicates parts available in assemblies only)	PART #	QTY	
-	<b>MP260 PRO FEED DRIVE</b>	537036	1	
-	REDUCER, PRO KC40/P15+NF003+SKH63-2C	533640	1	
1	SKH63-2C	533642	1	
2	NF003	533643	1	
3	KC40/P15	533641	1	
4	ARM, TORQUE	537037-1	1	
5	WASHER 6,4 ZC DIN 126 ISO 7091	F81053-1	2	
6	BOLT M6X12 HH ZC FT 8.8 DIN 933	F81001-7	2	
7	BUSHING, REDUCER	533731	1	
8	KEY	533732	2	
9	WASHER 10,2 ZC SPRING LOCK DIN 127	F81055-2	1	
10	WASHER 8,4 ZC DIN 126 ISO 7091	F81054-1	2	
11	NUT M8 ZC 8 NYLOCK DIN 982 ISO 7040	F81032-2	2	
12	BOLT, M8	533635-1	1	
13	NUT, M10	533733-1	1	
14	INDICATOR, POSITION (GRAVITY DRIVE)	546883	1	

## 4.6 Electric Box Bracket

537032\_001\_EN  
537032\_MANUAL

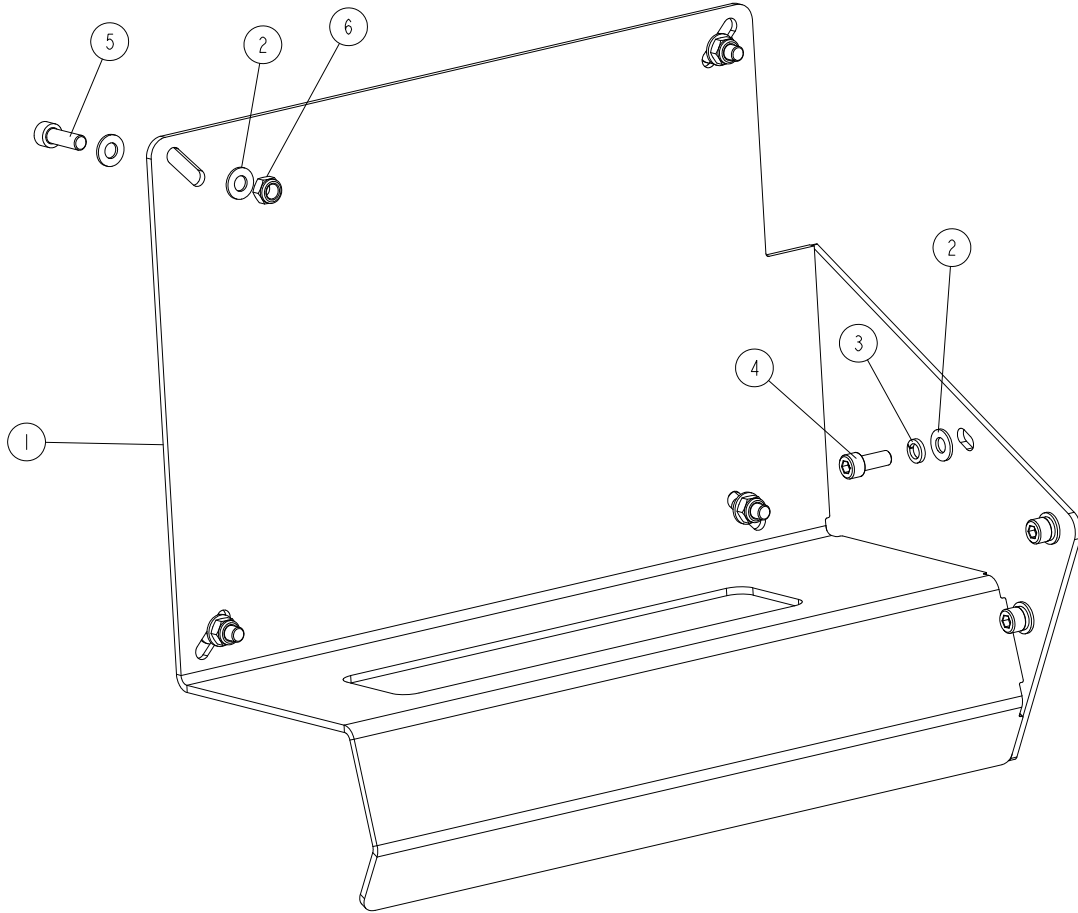

REF	DESCRIPTION (* indicates parts available in assemblies only)	PART #	QTY
-	<b>ELECTRIC BOX BRACKET-COMPLETE</b>	537032	1
1	ELECTRIC BOX BRACKET WELDMENT	533619-1	1
2	WASHER 8,4 ZC DIN 126 ISO 7091	F81054-1	11
3	WASHER 8,2 ZC SPRING LOCK DIN 127	F81054-4	3
4	SCREW M8X20 SHCS ZC 8.8 DIN 912 ISO 4762	F81002-30	3
5	SCREW M8X25 SHCS ZC 8.8 DIN 912 ISO 4762	F81002-21	4
6	NUT M8 ZC 8 NYLOCK DIN 982 ISO 7040	F81032-2	4

## 4.7 Electrical Box MP260 3x400V CE

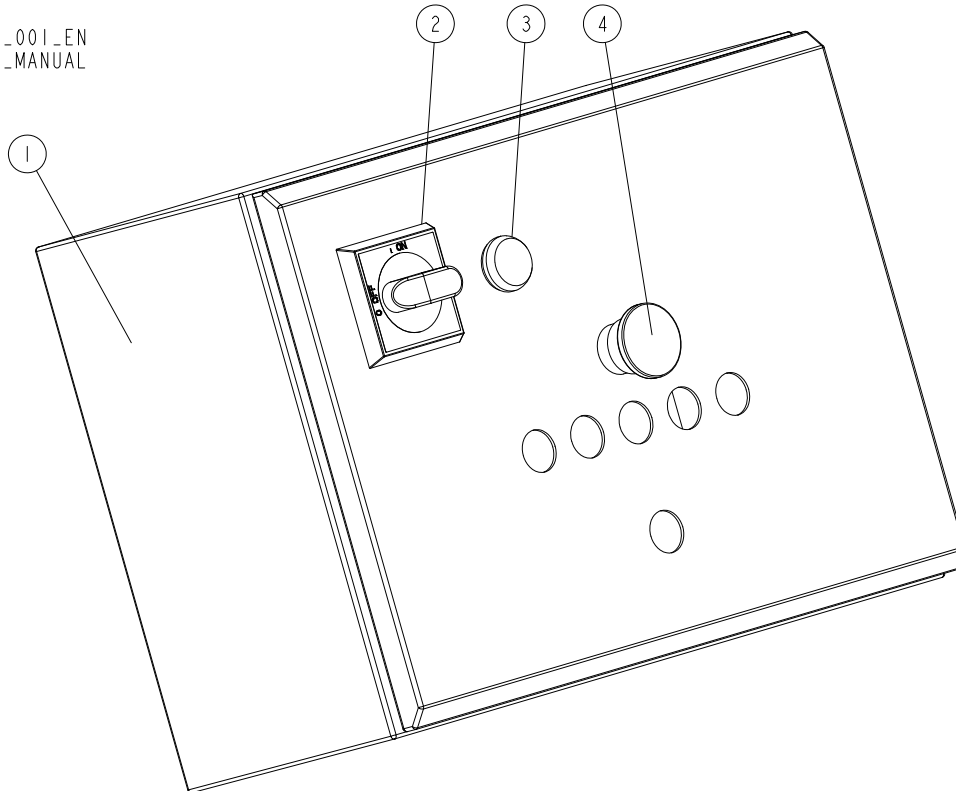
532791\_001\_EN  
532791\_MANUAL

REF	DESCRIPTION (* indicates parts available in assemblies only)	PART #	QTY
-	ELECTRICAL BOX MP260H 3x400V CE COMPLETE	532791 <sup>1</sup>	1
-	ELECTRICAL BOX MP260B COMPLETE	532791-2 <sup>2</sup>	1
1	ELECTRIC BOX	534148	1
2	HANDLE, OHB S2A1 ABB SWITCH	502312-1	1
3	LIGHT, XB7EV7BP WHITE CONTROL	519612	1
4	BUTTON, EMERGENCY STOP	502315	1

<sup>1</sup> Optional power supply kit (cable with plug) - 539809-3

<sup>2</sup> Optional power supply kit (cable with plug) - 539809-6

## SECTION 5 DECALS

### 5.1 Decals MP260

MP260EH13S-V\_002\_A  
 MP260EH13S-V\_MANUAL

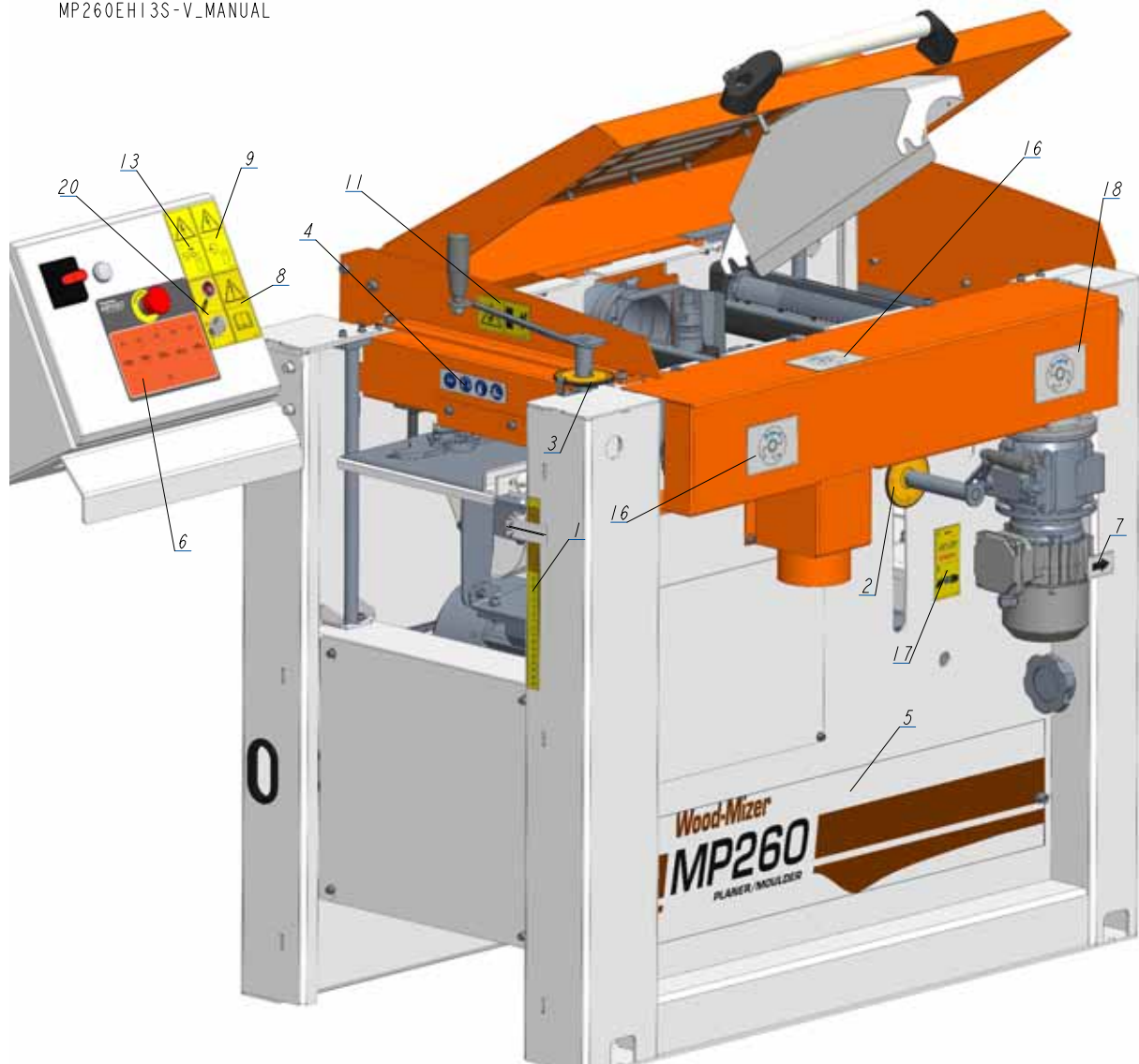

# 5 DECALS

Decals MP260

MP260EH13S-V\_002\_A  
MP260EH13S-V\_MANUAL

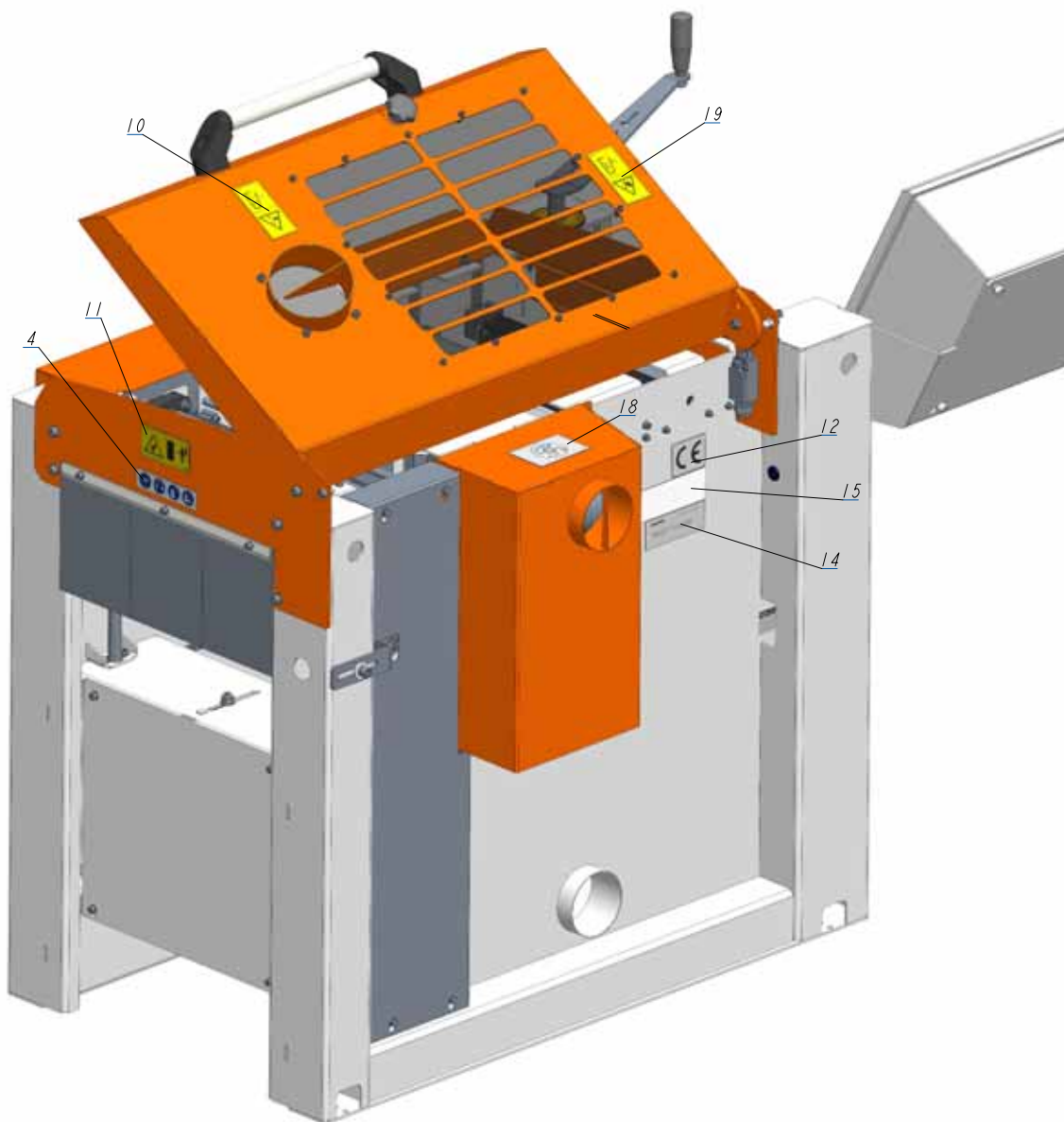

REF	DESCRIPTION (* indicates parts available in assemblies only)	PART #	QTY
-	<b>DECAL KIT, MP260</b>	541121	1
1	DECAL, VERTICAL SCALE	533579	1
2	DECAL, MP200 ROUND SCALE	533577	1
3	DECAL, MP200 ROUND SCALE	533577	1
4	DECAL - WARNING PICTOGRAMS	535402	2
5	DECAL MP260 PLANER TYPE	541122	1
6	DECAL CONTROL PANEL MP260	541123	1
7	DECAL, MOTOR DIRECTION	S20097	1
8	DECAL, READ THE OPERATOR MANUAL	096317	1
9	DECAL, HAZARDOUS VOLTAGE INSIDE THE ELECTRIC BOX (PICTOGRAM)	096316	1
10	DECAL, CLOSE GUARDS BEFORE OPERATING	099220	1
11	DECAL, "KEEP A SAFE DISTANCE" PICTOGRAM	099221H	2
12	DECAL, CE CERTIFIED SAWMILL - SMALL	P85070	1



REF	DESCRIPTION (* indicates parts available in assemblies only)	PART #	QTY	
13	DECAL, REMOVE THE PLUG BEFORE OPENING THE ELECTRIC BOX (PIC-	096319	1	
14	DECAL, EUROPEAN HEADQUARTER ADDRESS	015841	1	
15	DECAL, VIN	VIN	1	
16	DECAL, SHAFT ROTATION DIRECTION.	539444	2	
17	DECAL, USE THE CONTINUOUSLY VARIABLE TRANSMISSION WHEN THE	535252	1	
18	DECAL, MP160 SHAFT ROTATION DIRECTION	536401	2	
19	DECAL, HAND INJURY HAZARD (PICTOGRAM)	524993	1	
20	DECAL, HAZARDOUS VOLTAGE INSIDE THE ELECTRIC BOX (PICTOGRAM)	553801	1	

## SECTION 6 TABLE MP260

### 6.1 Table 265-000

546805\_001\_A  
546805\_MANUAL

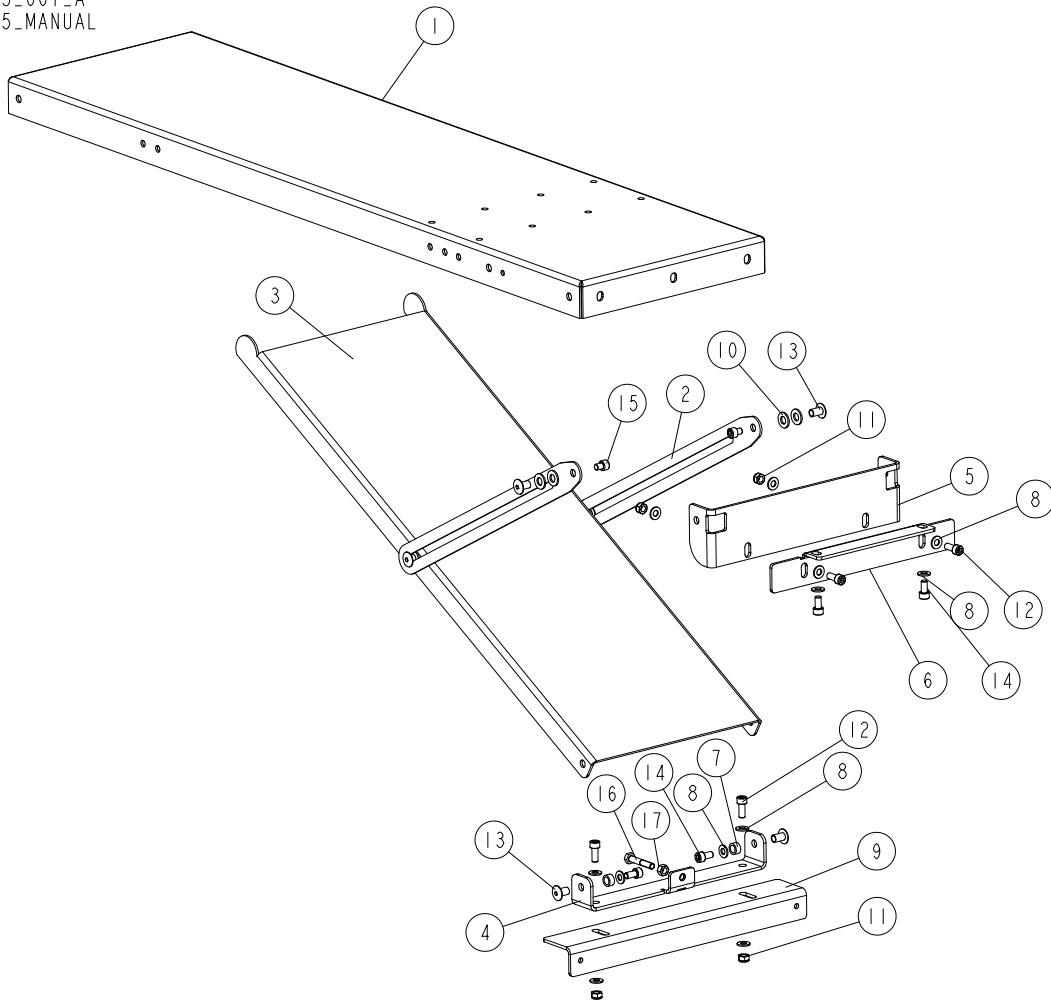

REF.	DESCRIPTION (* indicates parts available in assemblies only)	PART #	QTY
-	<b>TABLE, MP260</b>	546805	1
1	PLATE, TABLE 265	265-100-1	1
2	SLIDER, TABLE	533728-1	2
3	PLATE, TABLE SUPPORT 265-000	265-101-1	1
4	CHANNEL SECTION	265-103-1	1
5	BRACKET	265-106-2	1
6	BRACKET	265-102-1	1
7	BUSHING, 10.3/15-7.5	533724	4
8	WASHER, 8.4 FLAT ZINC	F81054-1	14
9	ANGLE SECTION	265-104-1	1
10	WASHER, 10,5 FLAT ZINC	F81055-1	6
11	NUT, M8-8-B-HEX NYLON ZINC LOCK	F81032-2	4
12	SCREW, M8X20-8.8-HEX SOCKET HEAD CAP ZINC	F81002-30	4
13	NUT, ERICSON M8 AN88 COLLAR ZINC	F81032-33	6
14	SCREW, M8X16-8.8-HEX SOCKET HEAD CAP ZINC	F81002-39	4

REF.	DESCRIPTION (* indicates parts available in assemblies only)	PART #	QTY	
15	SCREW, M8X10- 8.8- HEX SOCKET HEAD CAP ZINC	F81002-32	4	
16	BOLT M8X45-8.8	F81002-17	4	
17	NUT, M8 HEXAGON, GRADE 5.8 FREE ZINC	F81032-1	4	