

# Wood-Mizer®

## Parts List

---

**MF130 E3S**

**rev. A1.01**

---



**Safety is our #1 concern!** Read and understand all safety information and instructions before operating, setting up and maintaining this machine.

*Form #2503*

# Table of Contents

# Section-Page

<b>SECTION 1</b>	<b>GENERAL INFORMATION</b>	<b>1-1</b>
1.1	How To Use the Parts List.....	1-1
1.2	Sample Assembly .....	1-1
<b>SECTION 2</b>	<b>MF130 VERTICAL SPINDLE MOULDER</b>	<b>2-1</b>
2.1	MF130 Moulder Body .....	2-1
2.2	Decals .....	2-3
2.3	Sliding Table (No. 544324) .....	2-5
2.4	Sliding Table Bottom Guide (No. 544329) .....	2-6
2.5	Main Profile Side Handle (No. 544269) .....	2-7
2.6	Main Profile Side Handle (No. 544285) .....	2-8
2.7	Angle Fence (No. 546215) .....	2-9
2.8	Mount Assembly, Angle Fence (No. 546216) .....	2-10
2.9	Hold-Down Assembly (No. 542460) .....	2-11
2.10	Hold-Down Arm (No. 544367) .....	2-12
2.11	Side Clamp (No. 544350) .....	2-13
2.12	Left Fence (No. 545010) .....	2-14
2.13	Right Fence (No. 545024) .....	2-16
2.14	Fence Guide Support Plate (No. 545007) .....	2-17
2.15	Left Fence Panel Guide Assembly (No. 545012) .....	2-18
2.16	Right Fence Panel Guide Assembly (No. 564871) .....	2-19
2.17	Electrical Box Mount Bracket (No. 546234) .....	2-20
2.18	Cutter Guard (No. 546225) .....	2-21
2.19	Cutter Guard Mount (No. 546224) .....	2-22
2.20	Guard Assembly (No. 544346) .....	2-24
2.21	Guard Assembly (No. 544370) .....	2-26
2.22	Guard Plate Assembly (No. 544372) .....	2-27
2.23	Additional Part Kit. 546471 .....	2-28
<b>SECTION 3</b>	<b>MF130 MECHANICAL ASSEMBLY</b>	<b>3-1</b>
3.1	Mechanical Components .....	3-1
3.2	Cutter Positioning Assembly (No. 546239) .....	3-2
3.3	Vertical Arm (No. 537147) .....	3-4
3.4	Horizontal Arm (No. 537140) .....	3-5
3.5	Spindle Housing (No. 537153) .....	3-6
3.6	Up/Down Assembly (No. 537130) .....	3-7
3.7	Vertical Arm 2 (No. 537171) .....	3-9
3.8	Spindle In/Out Setting Assembly (Part No. 537174) .....	3-10
3.9	Worm Shaft Assembly (No. 537180) .....	3-11
3.10	Handle Assembly (No. 542521) .....	3-12
3.11	Spindle w/Drive Box & Guard (No. 537635) .....	3-13
3.12	Spindle Assembly (No. 537630) .....	3-14
3.13	Drive Box (Part No. 537610) .....	3-15

## Table of Contents

## Section-Page

3.14	Cutter Guard (No. 537120) .....	3-17	
3.15	Equipment for Curved Moulding (No. 546831) .....	3-18	
3.16	Short Spindle (No. 546823) .....	3-19	
3.17	Guard for Side Spindle in Vertical Position (No. 542465) .....	3-20	
3.18	Guard for Side Spindle in Horizontal Position (No. 542480) .....	3-21	
3.19	Side Plate (No. 542477) .....	3-22	
<b>SECTION 4      MOTOR &amp; ELECTRICAL BOX</b>			<b>4-1</b>
4.1	Motor & Electrical Box .....	4-1	
4.2	Safety Switch Assembly (3) .....	4-3	
4.3	Electrical Box (No. 536939) .....	4-4	
<b>SECTION 5      XY TABLE (OPTION)</b>			<b>5-1</b>
5.1	XY TABLE (Option). 546841 .....	5-1	
5.2	Complete Plate. 541422 .....	5-3	
5.3	Table Guides. 546487 .....	5-4	

## SECTION 1 GENERAL INFORMATION

### 1.1 How To Use the Parts List

- Use the index above to locate the assembly that contains the part you need.
- Go to the appropriate section and locate the part in the illustration.
- Use the number pointing to the part to locate the correct part number and description in the table.
- Parts shown indented under another part are included with that part.
- Parts marked with a diamond (◆) are only available in the assembly listed above the part.

See the sample table below. Sample Part #A01111 includes part F02222-2 and subassembly A03333. Subassembly A03333 includes part S04444-4 and subassembly K05555. The diamond (◆) indicates that S04444-4 is not available except in subassembly A03333. Subassembly K05555 includes parts M06666 and F07777-77. The diamond (◆) indicates M06666 is not available except in subassembly K05555.

1.2 Sample Assembly				
REF.	DESCRIPTION (◆ Indicates Parts Available In Assemblies Only)	PART #	QTY	
	Sample Assembly, Complete (Includes All Indented Parts Below)	A01111	1	
1	Sample Part	F02222-22	1	
	Sample Subassembly (Includes All Indented Parts Below)	A03333	1	
2	Sample Part (◆ Indicates Part Is Only Available With A03333)	S04444-4	1	◆
	Sample Subassembly (Includes All Indented Parts Below)	K05555	1	
3	Sample Part (◆ Indicates Part Is Only Available With K05555)	M06666	2	◆
4	Sample Part	F07777-77	1	

#### To Order Parts:

- From Europe call our European Headquarters and Manufacturing Facility in Kolo, Poland at **+48-63-2626000**. From the continental U.S., call our toll-free Parts hotline at **1-800-525-8100**. Have your customer number, vehicle identification number, and part numbers ready when you call. From other international locations, contact the Wood-Mizer distributor in your area for parts.

#### Office Hours:

Country	Monday - Friday	Saturday	Sunday
Poland	7-15	Closed	Closed
US	8 a.m.- 5 p.m.	8 a.m.- 12 p.m.	Closed



**CAUTION!** It is strongly recommended that only original spare parts be used.

## SECTION 2 MF130 VERTICAL SPINDLE MOULDER

### 2.1 MF130 Moulder Body

545040\_002  
545040\_MANUAL

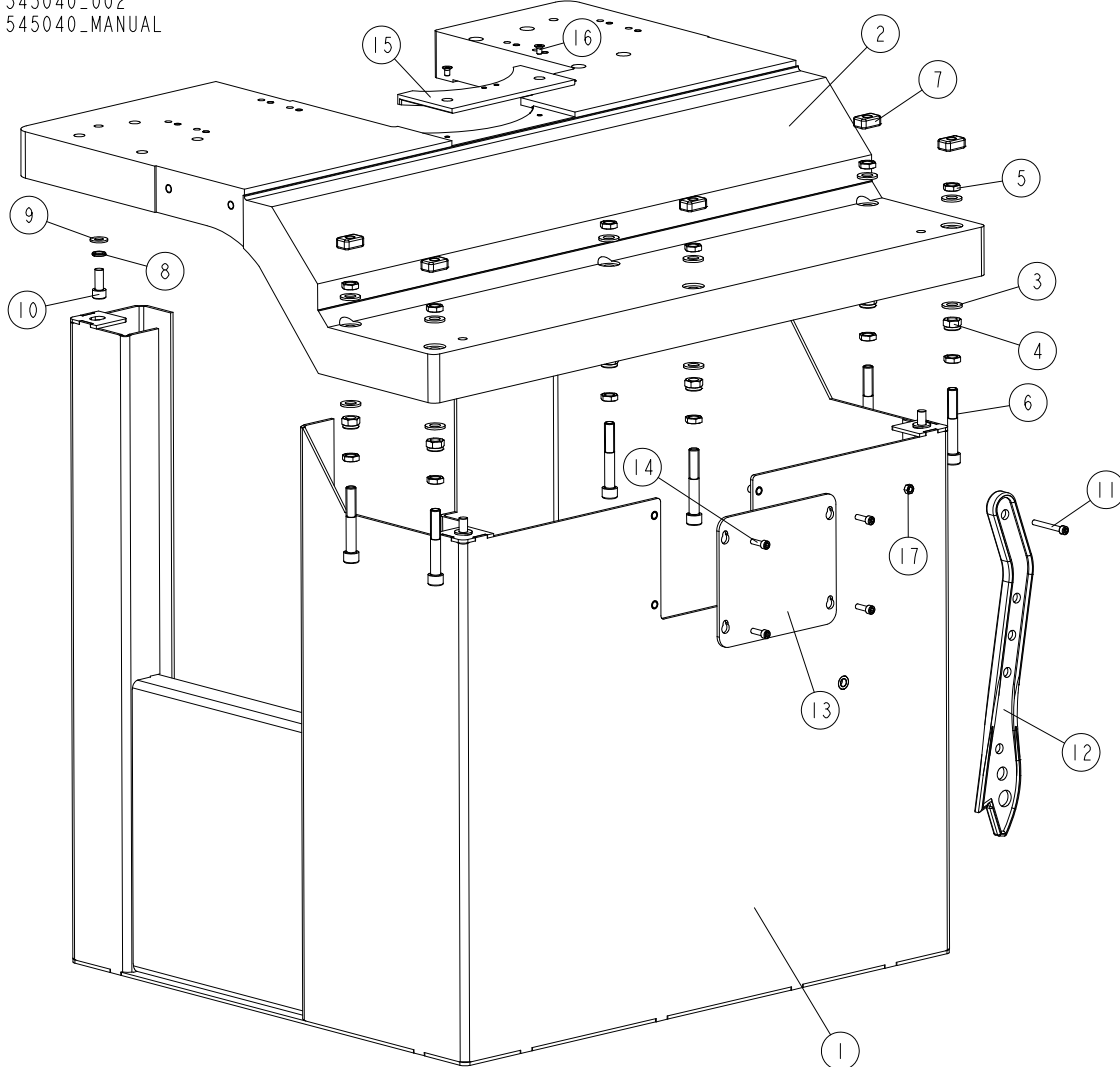

REF	DESCRIPTION (u indicates parts available in assemblies only)	PART #	QTY
-	<b>MF-130 VERTICAL SPINDLE MOULDER</b>	545040	1
1	BASE WELDMENT, MF130 MOULDER	545035-1	1
2	TABLE, CAST IRON	545036-1	1
3	WASHER, 13 FLAT ZINC	F81056-1	12
4	NUT, M12-8 HEX NYLON ZINC LOCK	F81034-2	6
5	NUT, M12-04-A THIN	F81034-6	12
6	SCREW, M12X80 HEX SOCKET SET W/FLAT	F81004-133	6
7	SPECIAL NUT	544132-1	5
8	WASHER, Z 10.2 SPLIT LOCK ZINC	F81055-2	4
9	WASHER, 10.5 FLAT ZINC	F81055-1	4
10	SCREW, M10X25 8.8 HEX SOCKET HEAD CAP ZI	F81003-32	4
11	SCREW M6X60 SHCS 8.8; DIN 912 ISO 4762	F81001-83	1
12	PUSHER	544293	1
13	PLATE, INSPECTION	546431-1	1



# MF130 VERTICAL SPINDLE MOULDER

## MF130 Moulder Body

---

REF	DESCRIPTION (u indicates parts available in assemblies only)	PART #	QTY	
14	SCREW, M6X20 8.8 SOCKET HEAD	F81001-22	4	
15	INSERT, ALUMINIUM TABLE	564862-1	1	
16	SCREW, TAPER M6X10-8.8 FE/ZN DIN7991	F81001-74	2	
17	NUT, M6 8 HEX ZINC	F81031-1	1	

## 2.2 Decals

MF130EH3S\_001  
MF130EH3S\_MANUAL

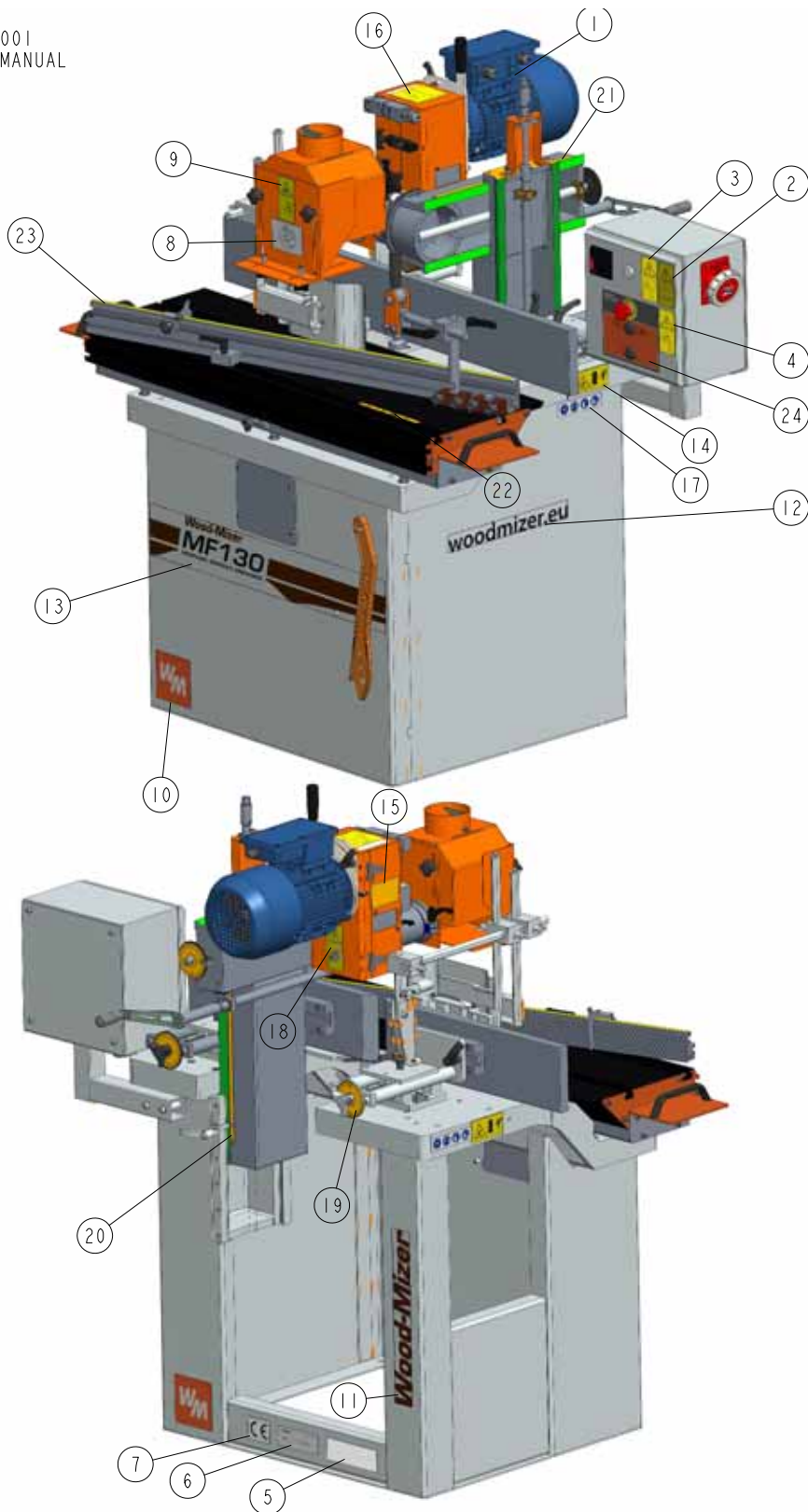

REF	DESCRIPTION (u indicates parts available in assemblies only)	PART #	QTY
-	DECAL KIT, MF130	553525	1
1	DECAL, MOTOR DIRECTION	S20097	1



# MF130 VERTICAL SPINDLE MOULDER

## Decals

REF	DESCRIPTION (u indicates parts available in assemblies only)	PART #	QTY	
2	DECAL, "READ THE OPERATOR'S MANUAL"	096317	1	
3	DECAL, HAZARDOUS VOLTAGE INSIDE THE ELEC	096316	1	
4	DECAL, REMOVE THE PLUG BEFORE OPENING TH	096319	1	
5	DECAL, VIN	VIN	1	
6	DECAL, EUROPEAN HEADQUARTER ADDRESS	015841	1	
7	DECAL, CE CERTIFIED SAWMILL - SMALL	P85070	1	
8	DECAL, SHAFT ROTATION DIRECTION	539444	1	
9	DECAL, HAND INJURY HAZARD (PICTOGRAM)	524993	1	
10	DECAL, WM	553364	2	
11	DECAL, WOOD-MIZER	553366	1	
12	DECAL, WOODMIZER.EU	553365	1	
13	DECAL, MF130 MACHINE TYPE	553524	1	
14	DECAL, "KEEP A SAFE DISTANCE" PICTOGRAM.	099221H	2	
15	DECAL	537618	1	
16	DECAL 1	537614	1	
17	DECAL - WARNING PICTOGRAMS	535402	2	
18	DECAL, CORRECT MOTOR REVOLUTIONS DIRECTION (PICTOGRAM)	553360	1	
19	DECAL, MP200 ROUND SCALE	533577	2	
20	STICKER-SCALE 2	537158	1	
21	STICKER-SCALE 1	537142	1	
22	MEASURE	544274	1	
23	GLUED MEASUREMENT	544287	1	
24	DECAL, MF130 ELECTRIC BOX	553802	1	



### 2.3 Sliding Table (No. 544324)

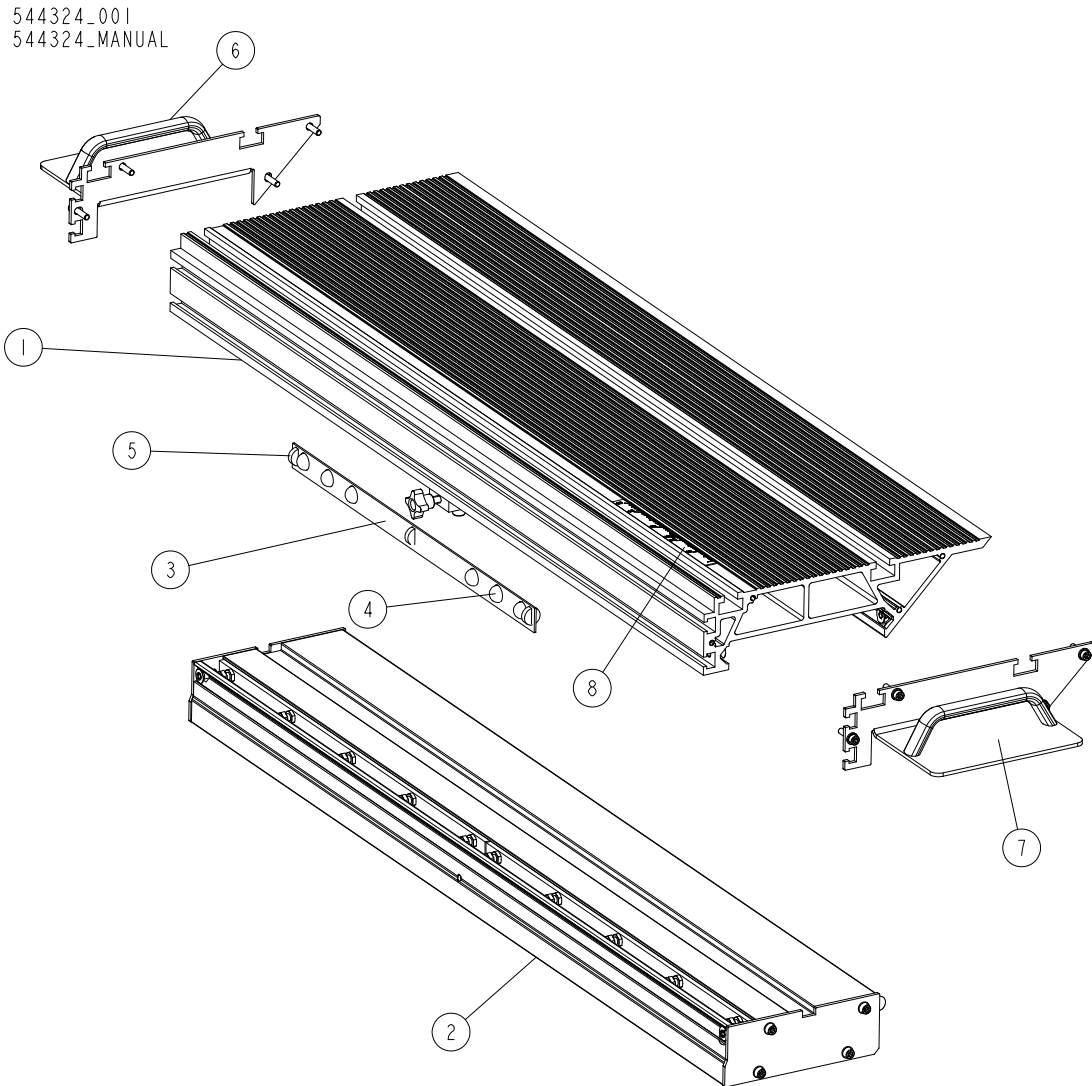

REF	DESCRIPTION (u indicates parts available in assemblies only)	PART #	QTY
-	<b>TABLE, SLIDING</b>	544324	1
1	PROFILE, MAIN	544325	1
2	GUIDE ASSEMBLY, SLIDING TABLE BOTTOM <a href="#">See Section 2.4</a>	544329	1
-	COMPLETE CART	544283	2
3	CAGE, BEARING BALL	544275	1
4	BEARING BALL FI 18 MM	546442	6
5	FELT INSERT FI 19MM, 3/4"	544277	3
6	MAIN PROFILE SIDE HANDLE <a href="#">See Section 2.5</a>	544269	1
7	MAIN PROFILE SIDE HANDLE <a href="#">See Section 2.6</a>	544285	1
8	MEASURE	544274	1

## 2.4 Sliding Table Bottom Guide (No. 544329)

544329\_001  
544329\_MANUAL

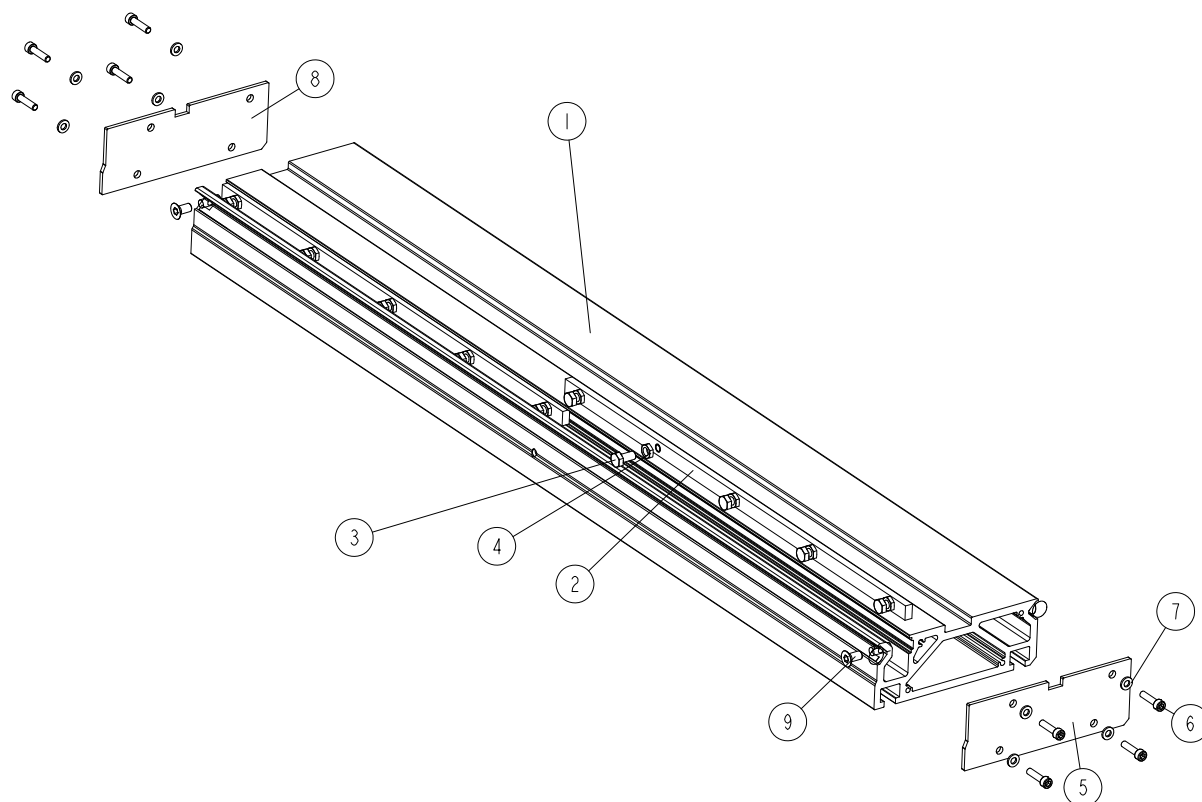

REF	DESCRIPTION (u indicates parts available in assemblies only)	PART #	QTY
-	<b>GUIDE ASSEMBLY, SLIDING TABLE BOTTOM</b>	544329	1
1	GUIDE, SLIDING TABLE BOTTOM	544330	1
2	BAR	544332	2
3	BOLT, M8X16-8.8-B HEX HEAD FULL THREAD Z	F81002-20	10
4	NUT M8 BLACK 04 DIN 439 ISO 4035;	F81032-17	10
5	LOWER PROFILE SIDE SHEET	544279-1	1
6	SCREW, M6X25 -8.8-HEX SOCKET HEAD CAP ZI	F81001-41	8
7	WASHER, 6.4 FLAT ZINC	F81053-1	8
8	LOWER PROFILE SIDE SHEET	546462-1	1
9	SCREW M8X16 HSFHS ZC 8.8 DIN7991 ISO106	F81002-115	4

2.5 Main Profile Side Handle (No. 544269)

544269\_001\_A  
544269\_MANUAL

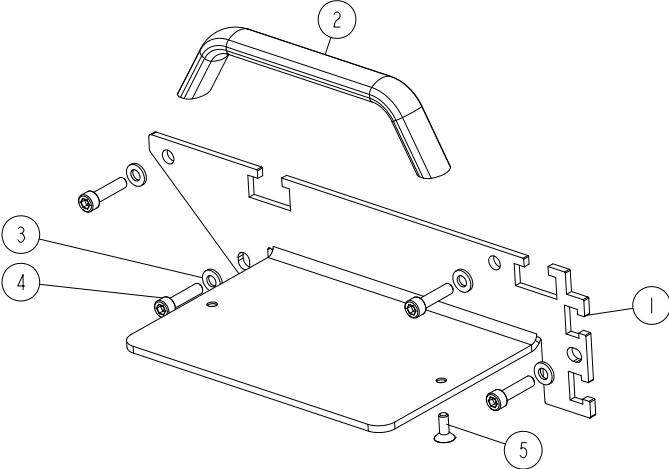

REF	DESCRIPTION (u indicates parts available in assemblies only)	PART #	QTY	
-	<b>MAIN PROFILE SIDE HANDLE</b>	544269	1	
1	HANDLE SHEET	544268-1	1	
2	HANDLES - Elesa+GANter GN_564-25-160	546491	1	
3	WASHER, 6.4 FLAT ZINC	F81053-1	4	
4	SCREW, M6X25 -8.8-FE/ZN5 HEX SOCKET HEAD	F81001-41	4	
5	SCREW M5X14-8.8 HEX	F81001-110	2	

**2.6 Main Profile Side Handle (No. 544285)**

544285\_001\_A  
544285\_MANUAL

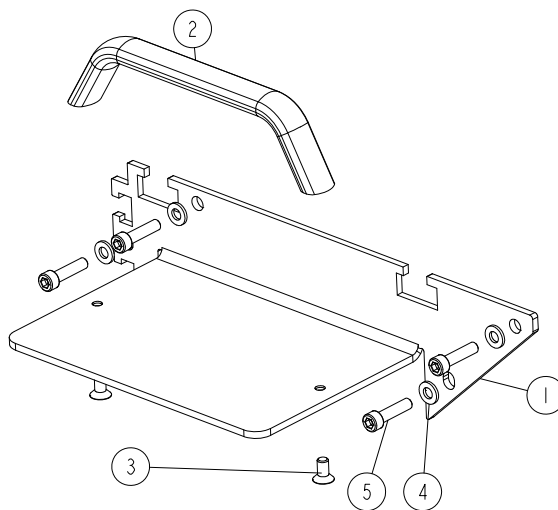

REF	DESCRIPTION (u indicates parts available in assemblies only)	PART #	QTY
-	<b>MAIN PROFILE SIDE HANDLE</b>	544285	1
1	HANDLE SHEET	544284-1	1
2	HANDLES - ELESA+GANter GN_564-25-160	546491	1
3	SCREW, M6X12-10.9 FE/ZN5 DIN7991	F81001-54	2
4	WASHER, 6.4 FLAT ZINC	F81053-1	4
5	SCREW, M6X25 -8.8-FE/ZN5 HEX SOCKET HEAD	F81001-41	4

## 2.7 Angle Fence (No. 546215)

546215\_001\_A  
546215\_MANUAL

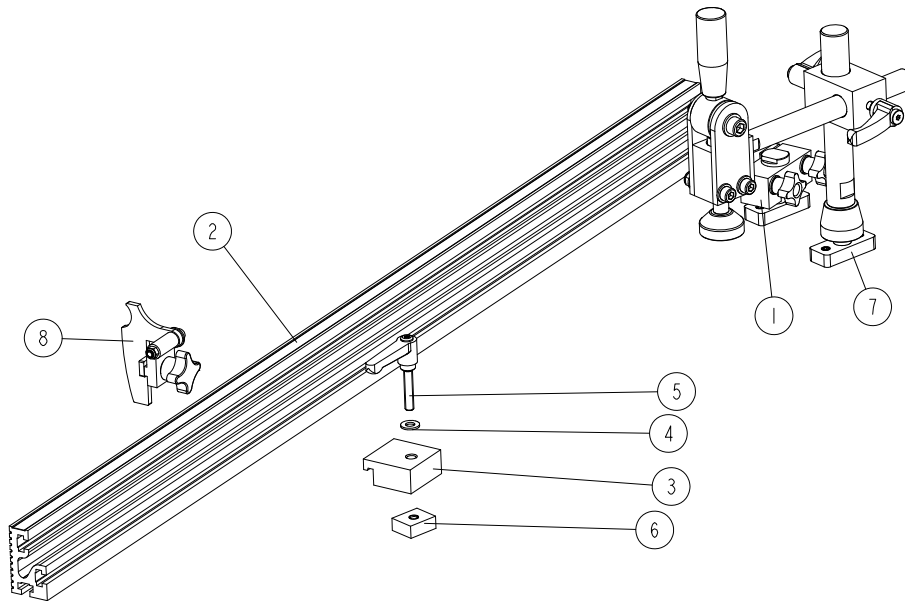

REF.	DESCRIPTION (* indicates parts available in assemblies only)	PART #	QTY
-	<b>FENCE ASSEMBLY, ANGLE</b>	546215	1
1	MOUNT ASSEMBLY <a href="#">See Section 2.8</a>	546216	1
2	FENCE W/MEASURE	544288	1
-	CLAMP	544292	1
3	BLOCK	544289-1	1
4	WASHER, 8.4 FLAT ZINC	F81054-1	1
5	LEVER, ELESA+GANter GN 302-63-M8-40-SW ADJUSTABLE HAND	544291	1
6	BLOCK W/THREADED HOLE	544290-1	1
7	ARM ASSEMBLY, HOLD-DOWN <a href="#">See Section 2.9</a>	542460	1
8	CLAMP, SIDE <a href="#">See Section 2.11</a>	544350	1

**2.8 Mount Assembly, Angle Fence (No. 546216)**

546216\_001  
546216\_MANUAL

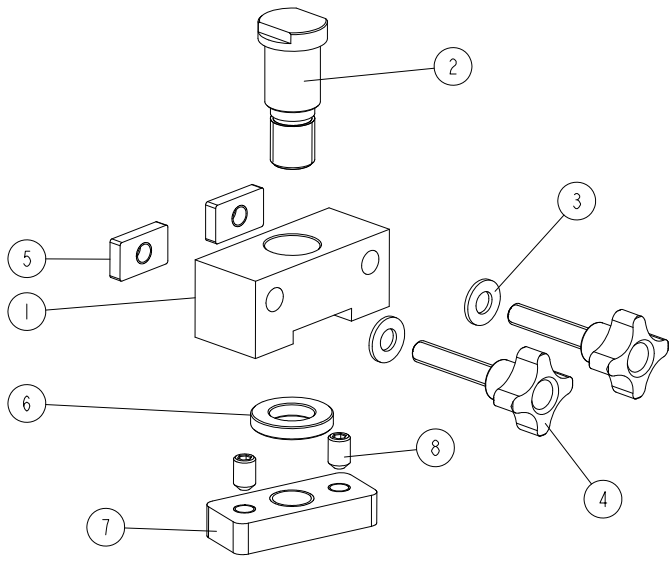

REF.	DESCRIPTION (* indicates parts available in assemblies only)	PART #	QTY
-	<b>MOUNT ASSEMBLY</b>	546216	1
1	BLOCK, MOUNT	544152-1	1
2	PIN	544146-1	1
3	WASHER, 8.4 FLAT ZINC	F81054-1	2
4	GRIP, KIPP K1089.43208X40 PALM	544155	2
5	M8 NUT	544153-1	2
6	WASHER	544355-1	1
7	BLOCK, GUIDE	544273-1	1
8	SCREW, M8X12-45H FE/ZN DIN914 HEX SOCKET SET W/CONE POINT	F81002-105	2

## 2.9 Hold-Down Assembly (No. 542460)

542460\_001  
542460\_MANUAL

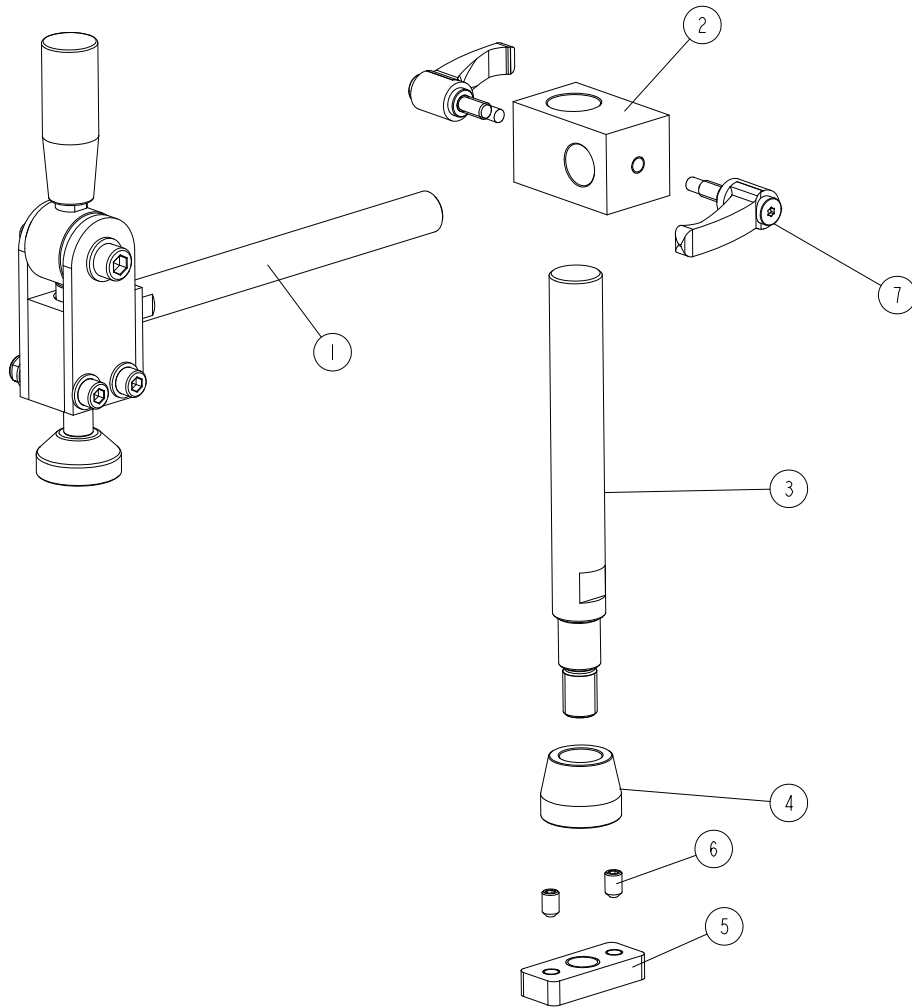

REF.	DESCRIPTION (* indicates parts available in assemblies only)	PART #	QTY
-	<b>HOLD-DOWN ASSEMBLY</b>	542460	1
1	ARM, HOLD-DOWN <a href="#">See Section 2.10</a>	544367	1
2	BLOCK	544353-1	1
3	ROD	544352-1	1
4	SLEEVE, CONICAL	544381-1	1
5	BLOCK, GUIDE	544273-1	1
6	SCREW, M8X12-45H FE/ZN DIN914/ PN82315 HEX SOCKET SET W/CONE POINT	F81002-105	2
7	HANDLE, ERZ.63 P-M8X16 ADJUSTABLE	535988	2

**2.10 Hold-Down Arm (No. 544367)**

544367\_001  
544367\_MANUAL

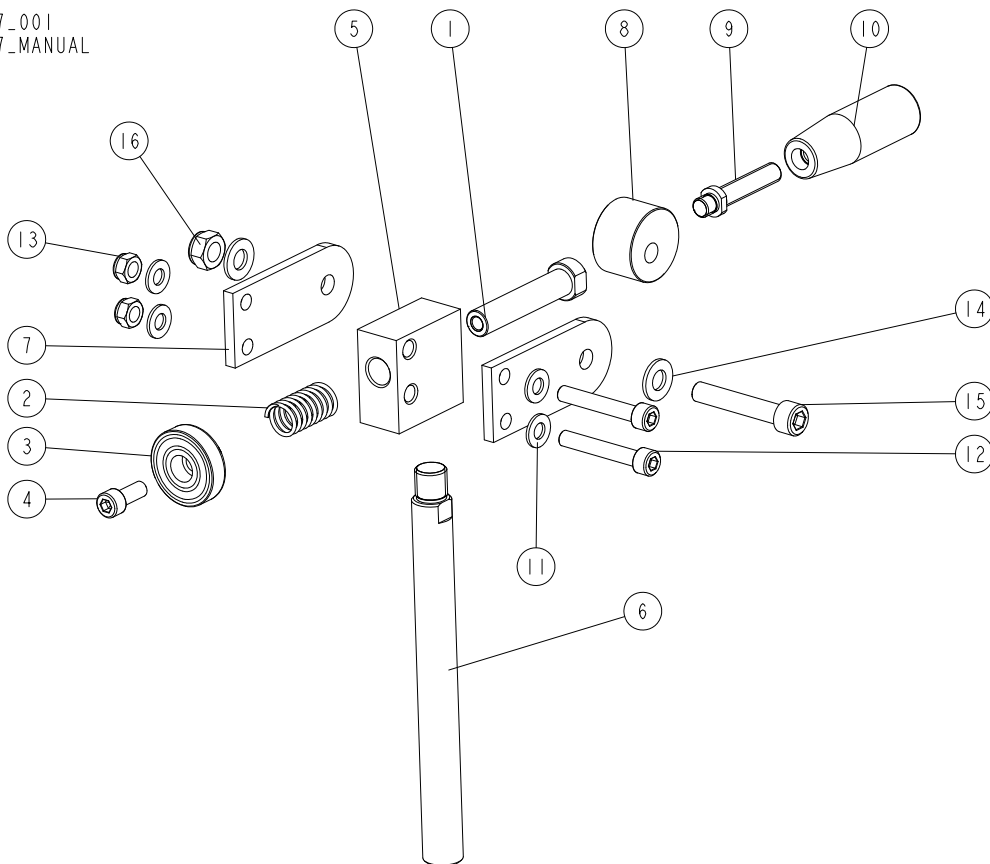

REF.	DESCRIPTION (* indicates parts available in assemblies only)	PART #	QTY
-	<b>ARM, HOLD-DOWN</b>	544367	1
-	HOLD-DOWN ASSEMBLY	544360	1
1	SHAFT II	544359-1	1
2	SPRING, 18.3X35X2	544361	1
3	ELEMENT, HOLD-DOWN	544358-1	1
4	SCREW, M8X20-8.8 HEX SOCKET HEAD CAP ZINC	F81002-30	1
5	BLOCK	544356-1	1
6	SHAFT	544357-1	1
7	PLATE	544362-1	2
-	HANDLE ASSEMBLY	544365	1
8	CAM	544363-1	1
9	PIN	544364-1	1
10	HANDLE, ELESA CYLINDRICAL	544366	1
11	WASHER, 8.4 FLAT ZINC	F81054-1	4
12	SCREW, M8X40-8.8 HEX SOCKET HEAD CAP ZINC	F81002-85	2
13	NUT, M8-8-B HEX NYLON ZINC LOCK	F81032-2	2
14	WASHER, 10.5 FLAT ZINC	F81055-1	2
15	SCREW, M10X55-8.8 HEX SOCKET HEAD CAP ZINC	F81003-55	1
16	NUT, M10-8-B HEX NYLON ZINC LOCK	F81033-1	1



## 2.11 Side Clamp (No. 544350)

544350\_001  
544350\_MANUAL

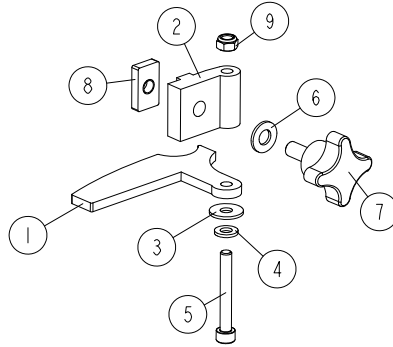

REF	DESCRIPTION (u indicates parts available in assemblies only)	PART #	QTY	
-	<b>CLAMP, SIDE</b>	544350	1	
1	PLATE	544347-1	1	
2	BLOCK, ALUMINUM	544348-1	1	
3	WASHER, 6.5 SPECIAL FLAT ZINC-PL.	F81053-11	1	
4	WASHER, 6.4 FLAT ZINC	F81053-1	1	
5	SCREW M6X45 SHC ZC 8.8 DIN 912 ISO 4762	F81001-86	1	
6	WASHER, 8.4 FLAT ZINC	F81054-1	1	
7	KNOB, 50/M8X25 (466406 MOSS)	500973	1	
8	NUT, M8	544153-1	1	
9	NUT, M6-8-B NYLON HEX ZINC LOCK	F81031-2	1	

**2.12 Left Fence (No. 545010)**

545010\_001  
545010\_MANUAL

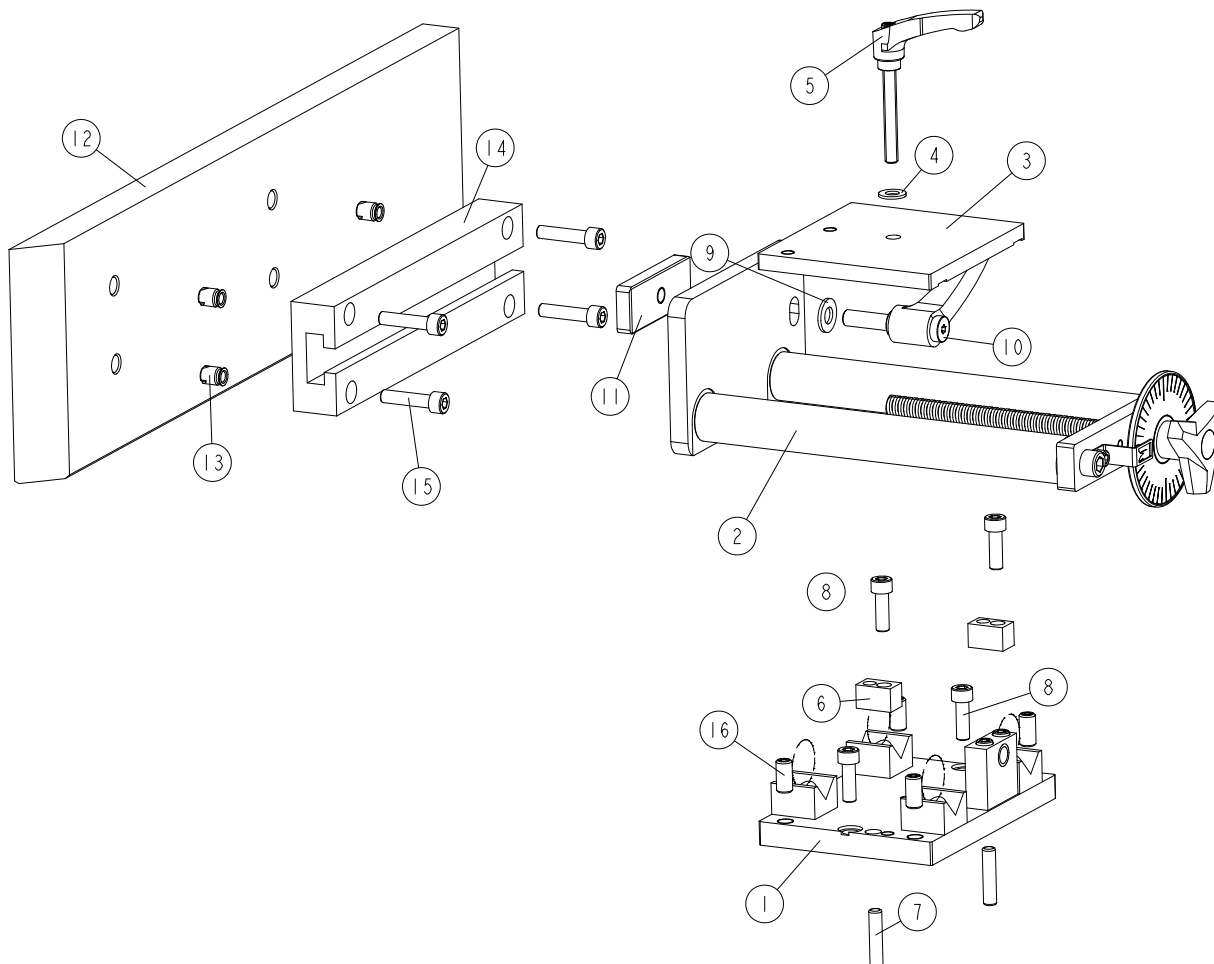

REF	DESCRIPTION (u indicates parts available in assemblies only)	PART #	QTY
-	<b>FENCE, LEFT - COMPLETE</b>	545010	1
1	PLATE, FENCE GUIDE SUPPORT <a href="#">See Section 2.14</a>	545007	1
2	GUIDE, FENCE PANEL - COMPLETE <a href="#">See Section 2.15</a>	545012	1
3	PLATE, CLAMPING	545003-1	1
4	WASHER, 8.4 FLAT ZINC	F81054-1	1
5	HANDLE, K0752.2081X60 ADJUSTABLE	545018	1
6	BLOCK, RETAINING	545008-1	2
7	PIN, 8X36 DIN6325 DOWEL	F05012-153	2
8	SCREW, M8X25 8.8 HEX SOCKET HEAD CAP ZIN	F81002-21	4
9	WASHER 10,5 ZC DIN 126 ISO 7091	F81055-1	1
10	HANDLE, M10X32 ADJUSTABLE	564866	1
11	BLOCK	564865-1	1
-	PANEL, FENCE	564881	1
12	PANEL, FENCE	564863-1	1
13	PANEL, LEFT FENCE	564867	4

REF	DESCRIPTION (u indicates parts available in assemblies only)	PART #	QTY	
14	INSERT, M8X14 SCREW THREADED	564864-1	1	
15	BRACKET, FENCE PANEL ALIGNMENT	F81002-101	4	
16	SCREW, M10X1X20 DIN 913 STAINLESS STEEL	F81015-1	4	

### 2.13 Right Fence (No. 545024)

545024\_001  
545024\_MANUAL

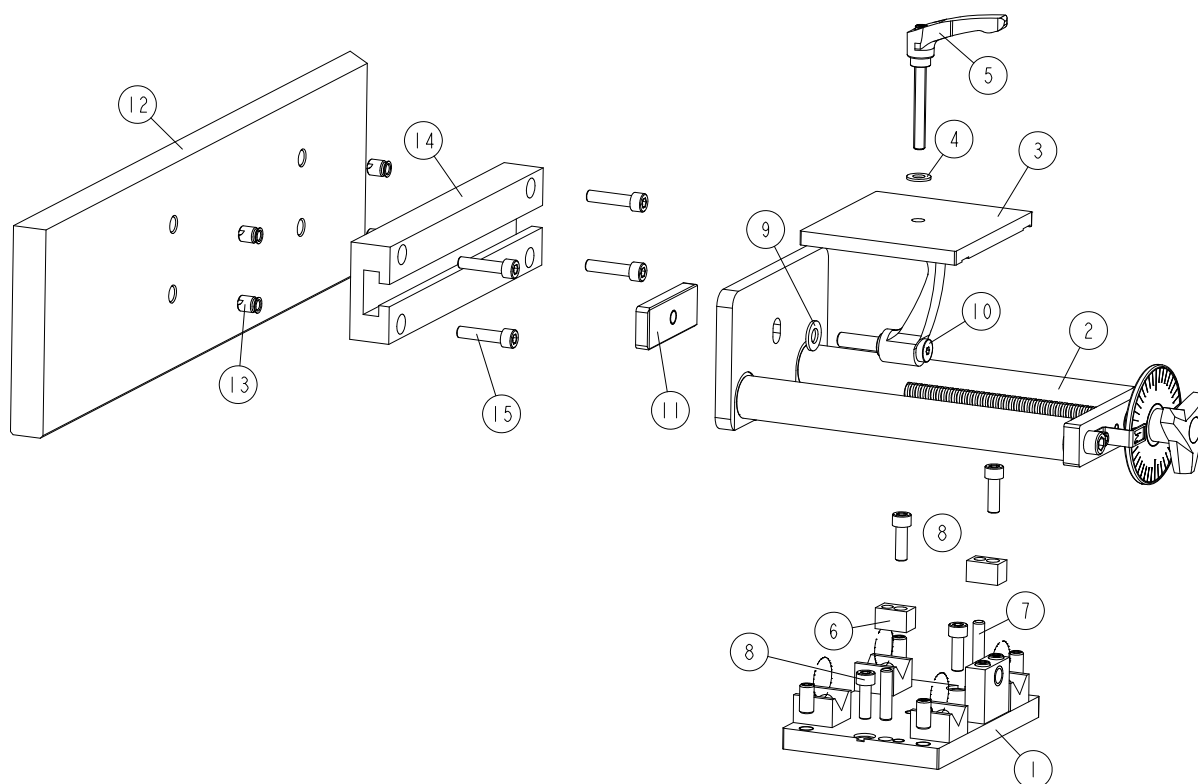

REF	DESCRIPTION (u indicates parts available in assemblies only)	PART #	QTY
-	<b>FENCE, RIGHT - COMPLETE</b>	545024	1
1	PLATE, FENCE GUIDE SUPPORT <a href="#">See Section 2.14</a>	545007	1
2	GUIDE, FENCE PANEL <a href="#">See Section 2.15</a>	564871	1
3	PLATE, CLAMPING	545003-1	1
4	WASHER, 8.4 FLAT ZINC	F81054-1	1
5	HANDLE, K0752.2081X60 ADJUSTABLE	545018	1
6	BLOCK, RETAINING	545008-1	2
7	PIN, 8X36 DIN6325 DOWEL	F05012-153	2
8	SCREW M6X45 SHC ZC 8.8 DIN 912 ISO 4762	F81001-86	2
9	SCREW, M8X25 8.8 HEX SOCKET HEAD CAP ZIN	F81002-21	2
10	WASHER 10,5 ZC DIN 126 ISO 7091	F81055-1	1
11	HANDLE, M10X32 ADJUSTABLE	564866	1
12	BLOCK	564865-1	1
-	PANEL, FENCE	564882	1
13	PANEL, RIGHT FENCE	564872-1	1
14	INSERT, M8X14 SCREW THREADED	564867	4
15	BRACKET, FENCE PANEL ALIGNMENT	564864-1	1
16	SCREW M8X35 SHCS ZC 8.8 DIN 912 ISO 4762	F81002-101	4

## 2.14 Fence Guide Support Plate (No. 545007)

545007\_001  
545007\_MANUAL

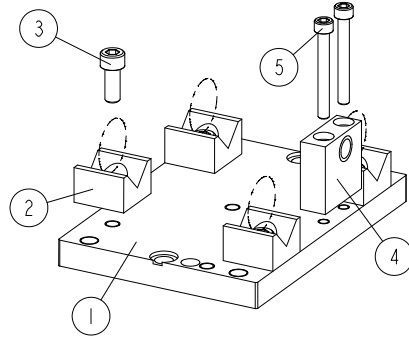

REF	DESCRIPTION (u indicates parts available in assemblies only)	PART #	QTY	
-	<b>PLATE, FENCE GUIDE SUPPORT</b>	545007	1	
1	PLATE	545006-1	1	
2	V-BLOCK	545005-1	4	
3	SCREW, M8X20-8.8 HEX SOCKET HEAD CAP ZIN	F81002-30	4	
4	NUT	545004	1	
5	BOLT. M6X35-8.8-FE/ZN5 PN-M/82302, HEX HEAD ZINC	F81001-118	2	

**2.15 Left Fence Panel Guide Assembly (No. 545012)**

545012\_001  
545012\_MANUAL

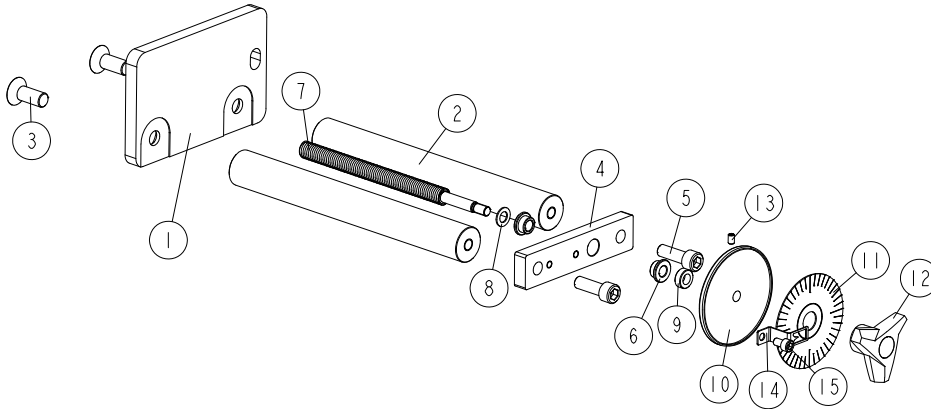

REF	DESCRIPTION (u indicates parts available in assemblies only)	PART #	QTY
-	<b>GUIDE, FENCE PANEL - COMPLETE</b>	545012	1
1	PLATE, LEFT FENCE	564868-1	1
2	ROD, GUIDE	545009-1	2
3	SCREW, M12X30-10.9 FLAT SOCKET HEAD CAP	F81004-18	2
4	PLATE, JOINING	545013-1	1
5	SCREW M10X30 SHCS ZC 8.8 DIN 912 ISO 476	F81003-110	2
6	BUSHING, AMES TYPE B 9-14-6/19-2.5 SELFO	545015	2
7	SCREW, 14X4 RIGHT T17547 CK15 TRAPEZOIDA	545016	1
8	WASHER, 9.2/16-1	545017	1
9	BUSHING, 9/16-6	545019-1	1
10	DISK, ROUND SCALE	545020	1
11	DECAL, MP200 ROUND SCALE	533577	1
12	KNOB, VB.839/63B-M8-C9; CODE 64635-C9 TH	545021	1
13	SCREW, M5X8 45H DIN 913 HEX SOCKET SET W	F81014-7	1
14	INDICATOR, SCALE	545023	1
15	SCREW, M6X10 8.8 HEX SOCKET HEAD CAP ZIN	F81001-12	1

2.16 Right Fence Panel Guide Assembly (No. 564871)

564871\_001  
564871

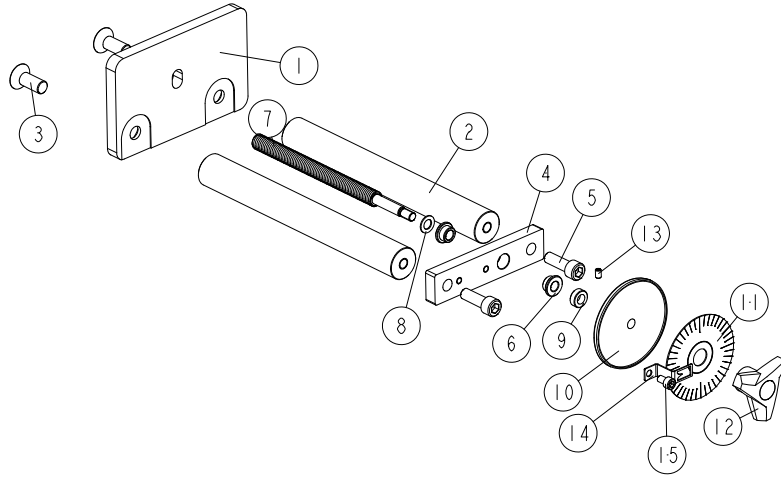

REF	DESCRIPTION (u indicates parts available in assemblies only)	PART #	QTY
-	<b>GUIDE, FENCE PANEL - COMPLETE</b>	564871	1
1	PLATE, RIGHT FENCE	564869-1	1
2	ROD, GUIDE	545009-1	2
3	SCREW, M12X30-10.9 FLAT SOCKET HEAD CAP	F81004-18	2
4	PLATE, JOINING	545013-1_	1
5	SCREW M10X30 SHCS ZC 8.8 DIN 912 ISO 476	F81003-110	2
6	BUSHING, AMES TYPE B 9-14-6/19-2.5 SELFO	545015	2
7	SCREW, 14X4 RIGHT T17547 CK15 TRAPEZOIDA	545016	1
8	WASHER, 9.2/16-1	545017	1
9	BUSHING, 9/16-6	545019-1	1
10	DISK, ROUND SCALE	545020	1
11	DECAL, MP200 ROUND SCALE	533577	1
12	KNOB, VB.839/63B-M8-C9; CODE 64635-C9 TH	545021	1
13	SCREW, M5X8 45H DIN 913 HEX SOCKET SET W	F81014-7	1
14	INDICATOR, SCALE	545023	1
15	SCREW, M6X10 8.8 HEX SOCKET HEAD CAP ZIN	F81001-12	1

**2.17 Electrical Box Mount Bracket (No. 546234)**

546234\_001  
546234\_MANUAL

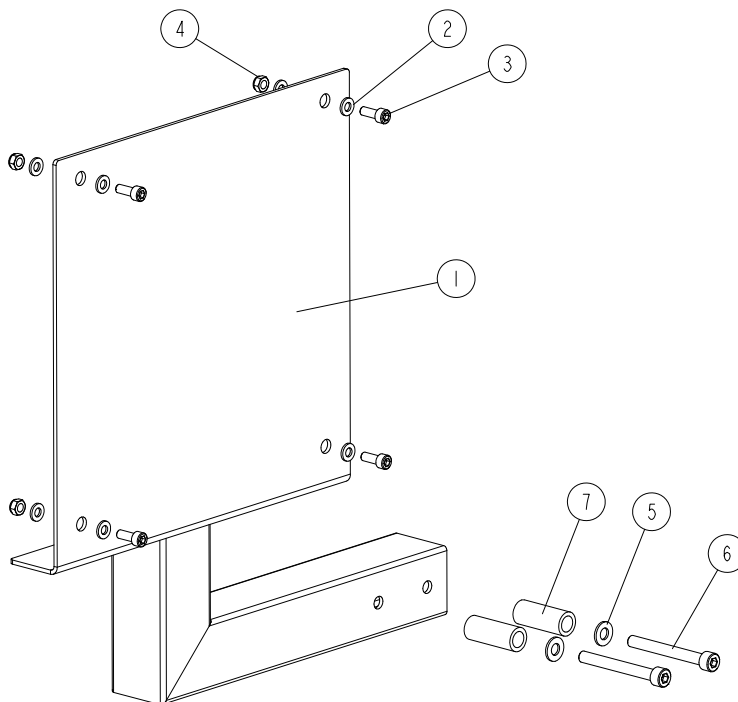

REF.	DESCRIPTION (* indicates parts available in assemblies only)	PART #	QTY
-	<b>BRACKET, ELECTRICAL BOX MOUNT</b>	546234	1
1	BRACKET WELDMENT, ELECTRICAL BOX MOUNT	546233-1	1
2	WASHER, 6.4 FLAT ZINC	F81053-1	8
3	SCREW, M6X16 8.8 HEX SOCKET HEAD CAP ZINC	F81001-21	4
4	NUT, M6-8-B HEX NYLON ZINC LOCK	F81031-2	4
5	WASHER, 8.4 FLAT ZINC	F81054-1	2
6	SCREW, ISO 4762 M8X70-8.8-A2E HEX SOCKET HEAD CAP	F81002-100	2
7	BUSHING, 17.2/11.4-43 SPACER	546488-1	2



## 2.18 Cutter Guard (No. 546225)

546225\_001  
546225\_MANUAL

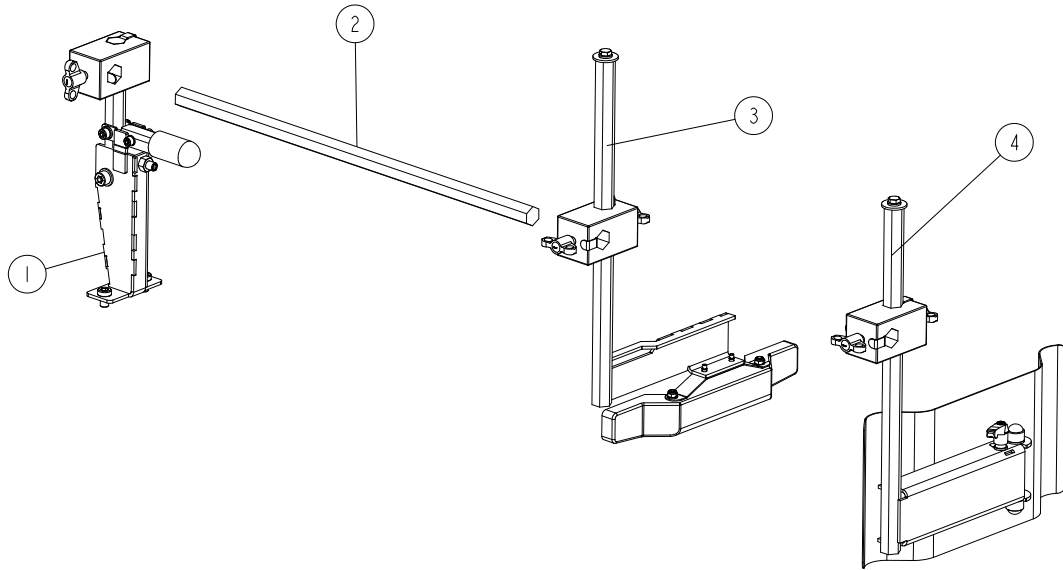

REF.	DESCRIPTION (* indicates parts available in assemblies only)	PART #	QTY
-	<b>GUARD, CUTTER</b>	546225	1
1	MOUNT, CUTTER GUARD <a href="#">See Section 2.19</a>	546224	1
2	ROD I	546226	1
3	GUARD ASSEMBLY <a href="#">See Section 2.20</a>	544346	1
4	GUARD ASSEMBLY <a href="#">See Section 2.21</a>	544370	1

## 2.19 Cutter Guard Mount (No. 546224)

546224\_001  
546224\_MANUAL

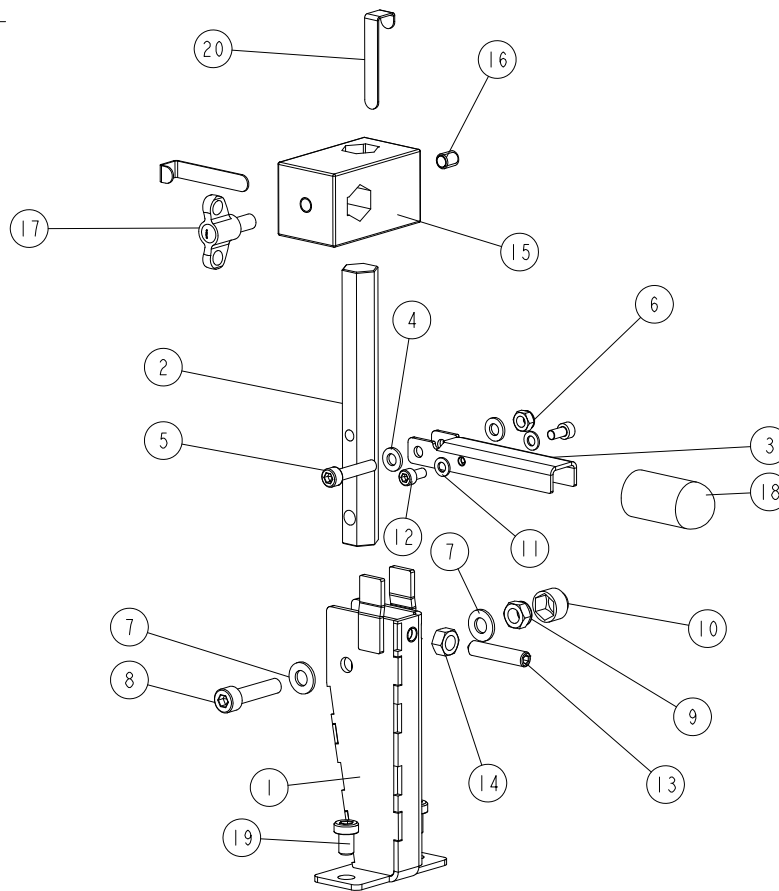

REF.	DESCRIPTION (* indicates parts available in assemblies only)	PART #	QTY
-	<b>MOUNT, CUTTER GUARD</b>	546224	1
1	CLAMP WELDMENT	546222-1	1
2	BAR, HEXAGON	546218	1
3	HANDLE, CLAMP	546217	1
4	WASHER, 6.4 FLAT ZINC	F81053-1	2
5	SCREW, M6X30-8.8 HEX SOCKET HEAD CAP ZINC	F81001-42	1
6	NUT, M6-8-B HEX NYLON ZINC LOCK	F81031-2	1
7	WASHER, 8.4 FLAT ZINC	F81054-1	2
8	SCREW, M8X35-8.8 HEX SOCKET HEAD CAP ZINC	F81002-101	1
9	NUT, M8-8-B HEX NYLON ZINC LOCK	F81032-2	1
10	CAP, M8 SCREW	522847	1
11	WASHER, 5.3 FLAT ZINC	F81052-1	2
12	SCREW, M5X10 DIN912 A2-70 HEX SOCKET HEAD CAP STAINLESS STEEL	F81000-23	2
13	SCREW, M8X40-45H GEOMET HEX SOCKET SET W/FLAT POINT	F81002-52	1
14	NUT, M8-8-B HEX ZINC	F81032-1	1
15	BLOCK	544342	1
16	SCREW, M8X10-45H DIN913 HEX SOCKET SET W/FLAT POINT	F81002-123	1
17	KNOB, M8X16 - ELESA + GANTER (EWN-P) WING	544344	1
18	COVER, CLAMP HANDLE	546228	1

REF.	DESCRIPTION (* indicates parts available in assemblies only)	PART #	QTY	
19	SCREW, M8X12 10.9 HEX SOCKET THIN HEAD CAP	F81002-110	2	
20	PLATE, CLAMPING	544343	2	

**2.20 Guard Assembly (No. 544346)**

544346\_001  
544346\_MANUAL

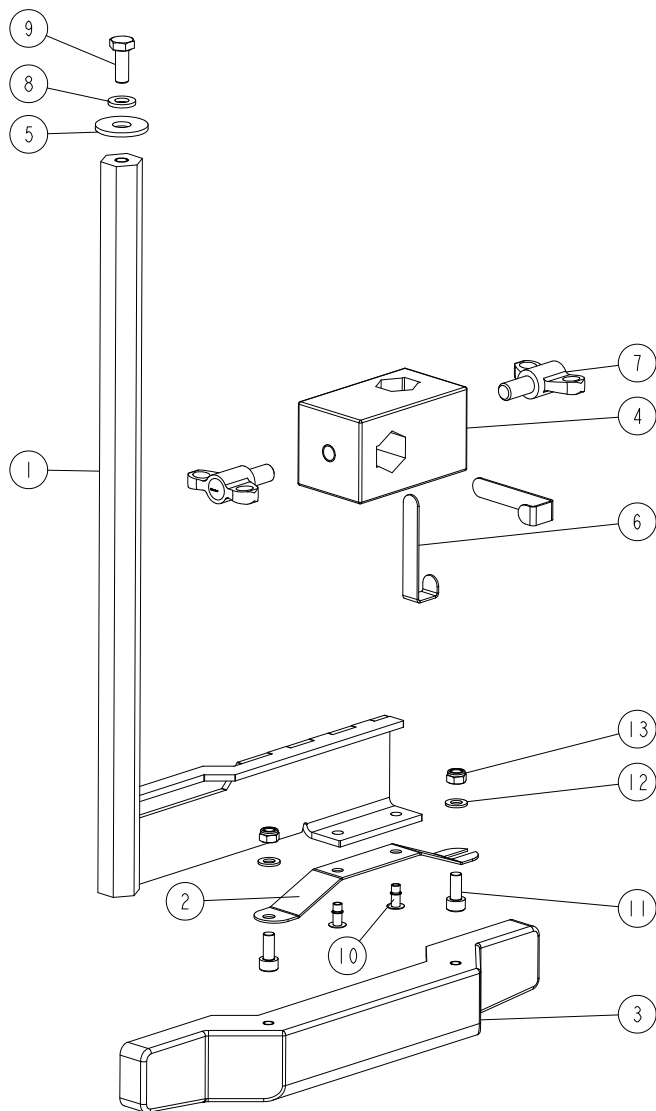

REF.	DESCRIPTION (* indicates parts available in assemblies only)	PART #	QTY
-	<b>GUARD ASSEMBLY</b>	544346	1
1	ARM WELDMENT	544345	1
2	PLATE, GUARD	544339-1	1
3	GUARD	544336	1
4	BLOCK	544342	1
5	WASHER, ISO 7093-1-8-200 HV-A2E	F81054-11	1
6	PLATE, CLAMPING	544343	2
7	KNOB, M8X16 - ELESA + GANTER (EWN-P) WING	544344	2
8	WASHER, 6.4 FLAT ZINC	F81053-1	1
9	BOLT, M6X16-8.8 HEX HEAD FULL THREAD ZINC	F81001-15	1
10	RIVET, AL 4X10 BREAK MANDREL BLIND	F81021-15	2
11	SCREW, M5X12 8.8 DIN 912 ISO 4762 HEX SOCKET HEAD CAP ZINC	F81000-53	2
12	WASHER, 5.3 FLAT ZINC	F81052-1	2

---

REF.	DESCRIPTION (* indicates parts available in assemblies only)	PART #	QTY	
13	NUT, M5-8 DIN985 HEX NYLON ZINC LOCK	F81030-2	2	

## 2.21 Guard Assembly (No. 544370)

544370\_001  
544370\_MANUAL

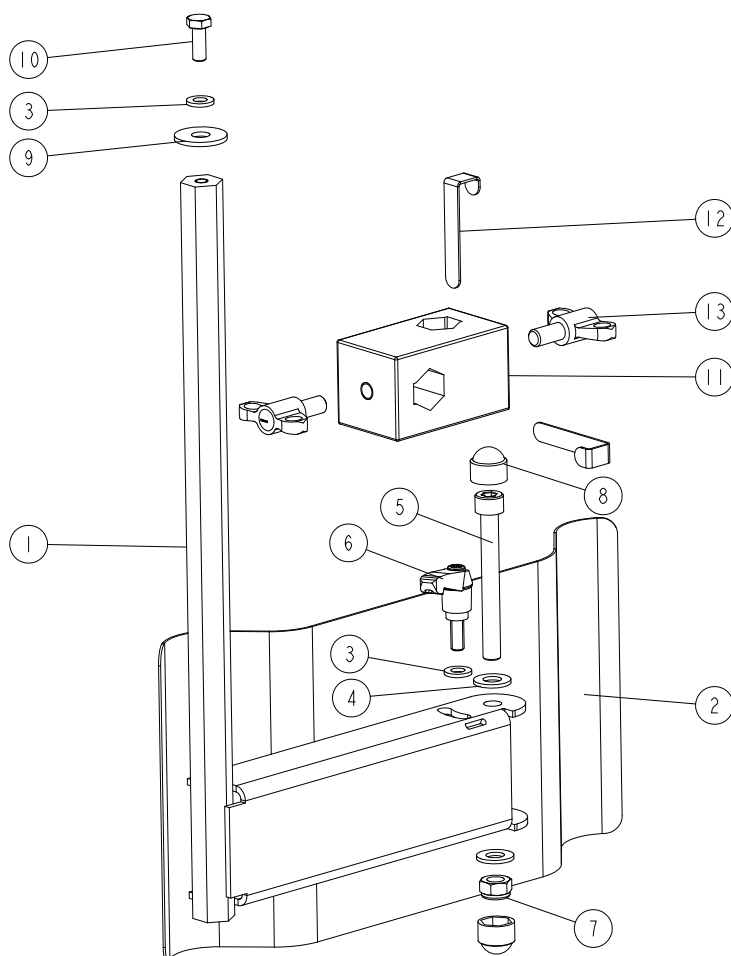

REF.	DESCRIPTION (* indicates parts available in assemblies only)	PART #	QTY
-	<b>GUARD ASSEMBLY</b>	544370	1
1	ARM WELDMENT, GUARD	544375-1	1
2	PLATE ASSEMBLY, GUARD <a href="#">See Section 2.22</a>	544372	1
3	WASHER, 6.4 FLAT ZINC	F81053-1	2
4	WASHER, 8.4 FLAT ZINC	F81054-1	2
5	SCREW, ISO 4762 M8X70-8.8-A2E HEX SOCKET HEAD CAP	F81002-100	1
6	HANDLE, M6X15 ADJUSTABLE	544376	1
7	NUT, M8-8-B HEX NYLON ZINC LOCK	F81032-2	1
8	CAP, M8 SCREW	522847	2
9	WASHER, ISO 7093-1-8-200 HV-A2E	F81054-11	1
10	BOLT, M6X16-8.8 HEX HEAD FULL THREAD ZINC	F81001-15	1
11	BLOCK	544342	1
12	PLATE, CLAMPING	544343	2
13	KNOB, M8X16 - ELESA + GANTER (EWN-P) WING	544344	2

## 2.22 Guard Plate Assembly (No. 544372)

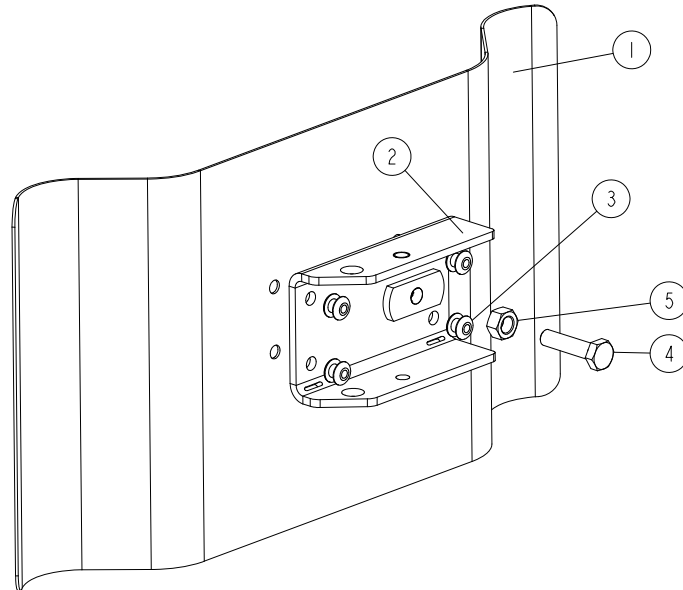
544372\_001  
544372\_MANUAL

REF.	DESCRIPTION (* indicates parts available in assemblies only)	PART #	QTY	
-	<b>PLATE ASSEMBLY, GUARD</b>	544372	1	
1	PLATE, GUARD	544368	1	
2	PLATE WELDMENT, MOUNT	544371-1	1	
3	RIVET, 5,0X8 A2/A2 STAINLESS STEEL BREAK MANDREL BLIND	F81021-3	4	
4	BOLT, M6X25 -8.8 HEX HEAD FULL THREAD ZINC	F81001-3	1	
5	NUT, M6 8 HEX ZINC	F81031-1	1	

**2.23 Additional Part Kit. 546471**

546471\_001  
546471\_MANUAL

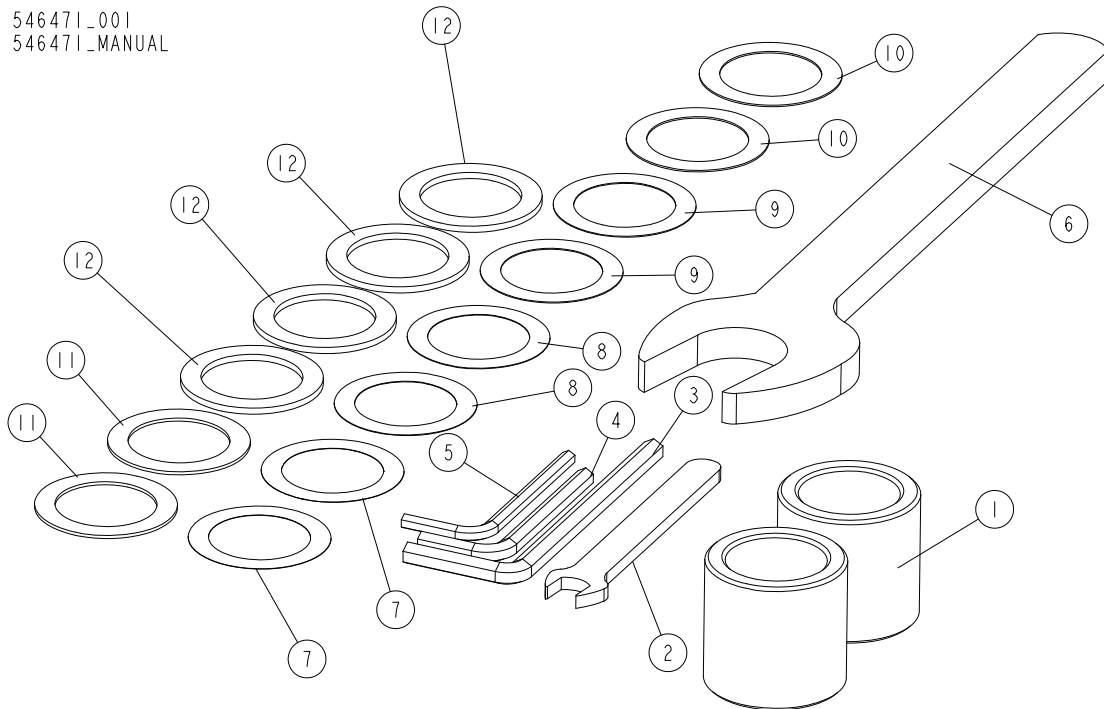

Ref	DESCRIPTION (* indicates parts available in assemblies only)	PART #	QTY
-	<b>MF130 ADDITIONAL PART KIT</b>	546471	1
1	BUSHING 30/42-40.2 ZINC-PLATED	535848-1	2
-	MP160 WRENCH KIT	535185	1
2	WRENCH, 10 FLAT	541315	1
3	WRENCH, 6MM ALLEN	535186	1
4	WRENCH, 5 ALLEN	092915	1
5	WRENCH, 4MM ALLEN	093368	1
6	WRENCH 30 DIN 894	537649	1
7	WASHER 30/42-0.1 ZC DIN 988	F81069-6	2
8	WASHER 30/42-0.2 ZC DIN 988	F81069-5	2
9	WASHER 30/42-0.3 ZC DIN 988	F81069-4	2
10	WASHER 30/42-0.5 ZC DIN 988	F81069-3	2
11	WASHER 30/42-1 ZC DIN 988	F81069-2	2
12	WASHER 30/42-2 ZC DIN 988	F81069-1	4



SECTION 3 MF130 MECHANICAL ASSEMBLY

3.1 Mechanical Components

544334\_001  
544334\_MANUAL

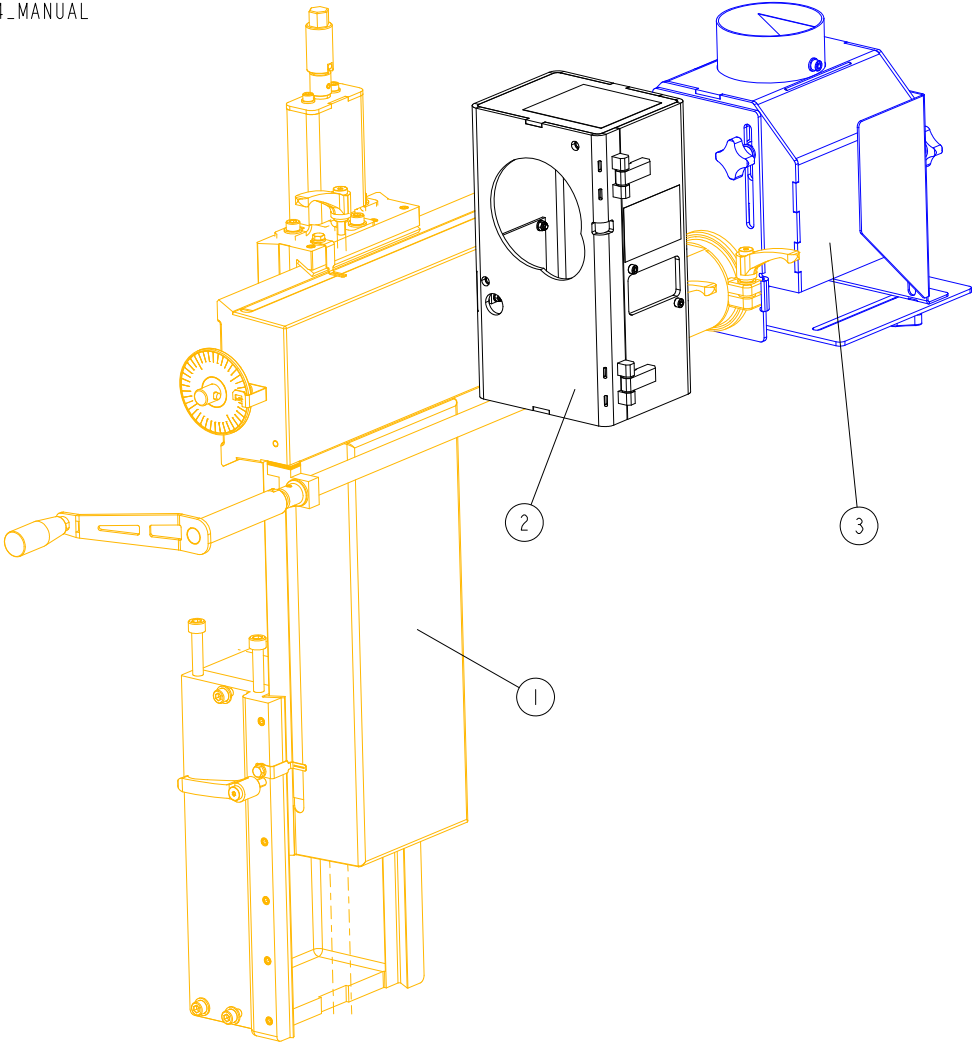

REF	DESCRIPTION (u indicates parts available in assemblies only)	PART #	QTY	
-	MECHANICAL ASSEMBLY, MF130	544334	1	
1	CUTTER POSITIONING ASSEMBLY <a href="#">See Section 3.2</a>	546239	1	
2	BOX, DRIVE <a href="#">See Section 3.11</a>	546369	1	
3	GUARD, CUTTER - COMPLETE <a href="#">See Section 3.11</a>	537120	1	

### 3.2 Cutter Positioning Assembly (No. 546239)

546239\_001  
546239\_MANUAL

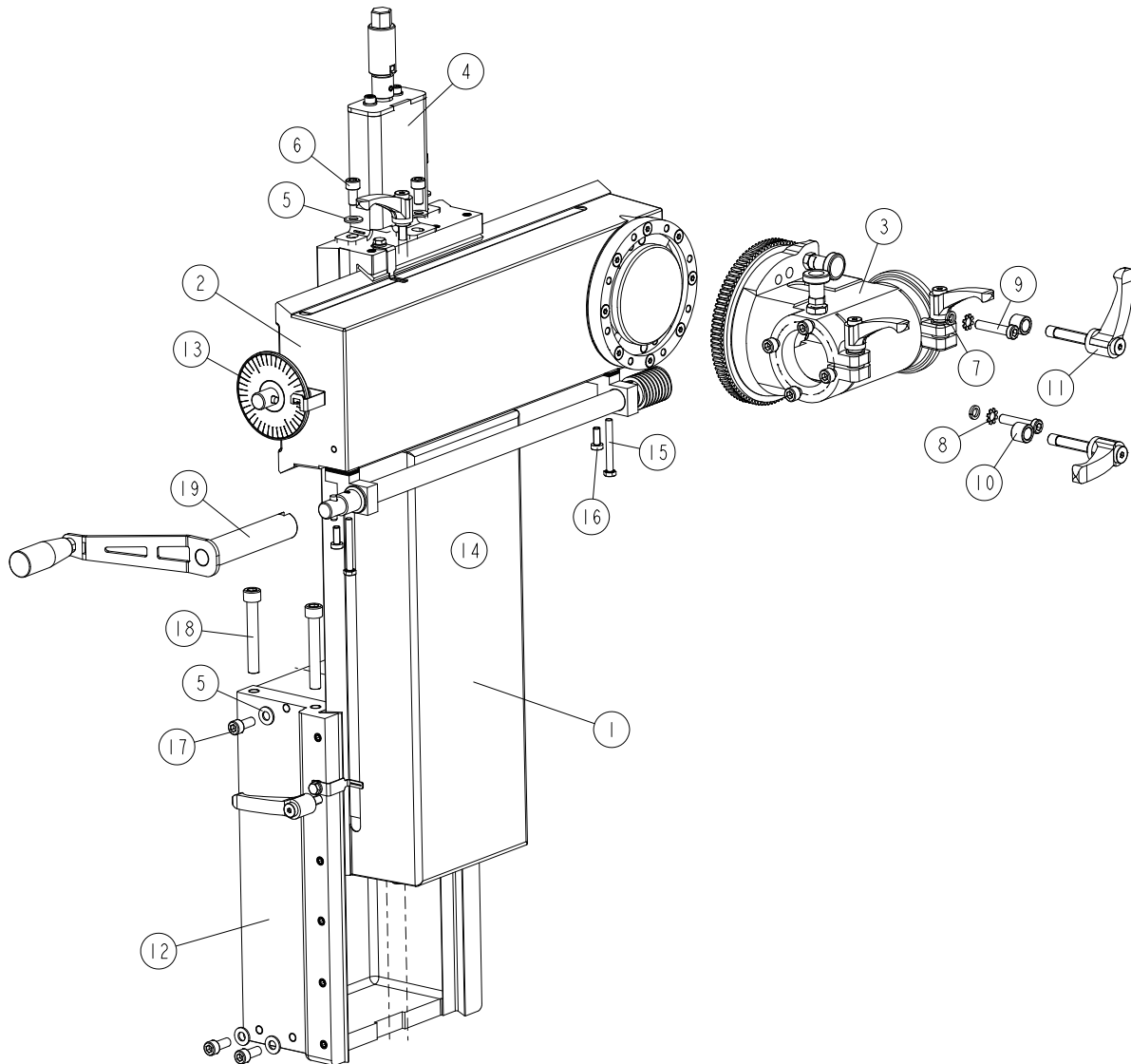

REF	DESCRIPTION (u indicates parts available in assemblies only)	PART #	QTY
-	<b>CUTTER POSITIONING ASSEMBLY</b>	546239	1
1	VERTICAL ARM - COMPLETE <a href="#">See Section 3.3</a>	537147	1
2	HORIZONTAL ARM - COMPLETE <a href="#">See Section 3.4</a>	546377	1
3	HOUSING, SPINDLE CAST IRON - COMPLETE <a href="#">See Section 3.5</a>	537153	1
4	UP/DOWN ASSEMBLY <a href="#">See Section 3.6</a>	537130	1
5	WASHER, 8.4 FLAT ZINC	F81054-1	6
6	SCREW, M8X16-8.8 HEX SOCKET HEAD CAP ZIN	F81002-39	3
7	WASHER 8,2 ZC SPRING LOCK DIN 127	F81054-4	2
8	WASHER, 8.4 EXTERIOR STAR LOCK ZINC	F81054-3	2
9	SCREW, M8X40-8.8-FE/ZN5 DIN 7984 ISO 145	F81002-81	2
10	BUSHING	546407-1	2
11	HANDLE, ERZ.78 P-M10X50 ADJUSTABLE	534214	2

REF	DESCRIPTION (u indicates parts available in assemblies only)	PART #	QTY	
12	VERTICAL ARM 2 - COMPLETE <a href="#">See Section 3.7</a>	537171	1	
13	SPINDLE IN/OUT SETTING ASSEMBLY <a href="#">See Section 3.8</a>	537174	1	
14	WORM SHAFT- ASSEMBLY <a href="#">See Section 3.9</a>	546375	1	
15	BOLT, M6X50-8.8 HEX HEAD ZINC	F81001-62	2	
16	SCREW M6X16 LHSCS 8.8 DIN 6912	F81001-46	2	
17	SCREW, M8X20-8.8 HEX SOCKET HEAD CAP ZIN	F81002-30	3	
18	SCREW, M10X70-8.8 HEX SOCKET HEAD CAP Z	F81003-60	4	
19	HANDLE, COMPLETE <a href="#">See Section 3.10</a>	542521	1	

### 3.3 Vertical Arm (No. 537147)

537147\_001\_A  
537147\_MANUAL

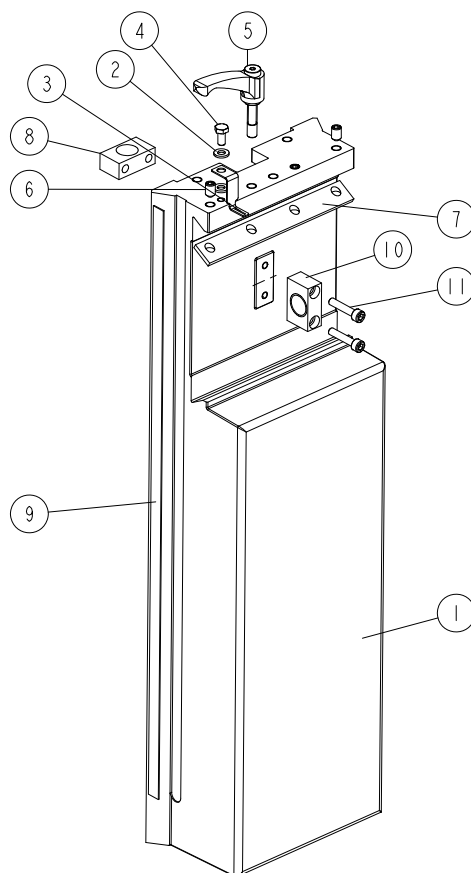

Ref	DESCRIPTION (* indicates parts available in assemblies only)	PART #	QTY
-	<b>VERTICAL ARM - COMPLETE</b>	537147	1
1	CAST IRON VERTICAL-MECHANICAL PROCESSING	542632-1	1
2	WASHER 6,4 ZC DIN 126 ISO 7091	F81053-1	2
3	INDICATOR, SCALE 1	537144	1
4	BOLT M6X12 HH ZC FT 8.8 DIN 933	F81001-7	1
5	ADJUSTABLE HANDLE ERZ.63 P-M8X32	537149	1
6	SCREW M8X12 HSS W/CONE POINT ZC 45H DIN 914	F81002-105	3
7	SIDESLIP 1	537150	1
8	MOUNTING BLOCK	537136-1	1
9	STICKER-SCALE 2	537158	1
10	MOUNTING BLOCK 2	537173-1	1
11	SCREW M6X30 SHCS ZC 8.8 DIN 912 ISO 4762	F81001-42	2

### 3.4 Horizontal Arm (No. 537140)

537140\_001\_MF  
537140\_MANUAL

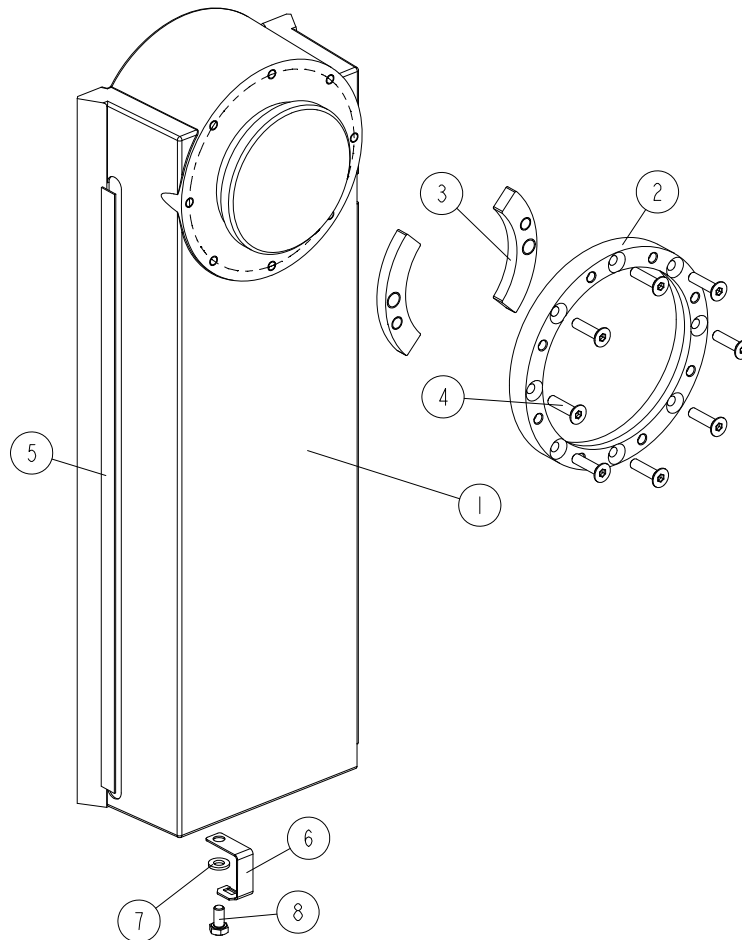

REF	DESCRIPTION (u indicates parts available in assemblies only)	PART #	QTY
-	<b>HORIZONTAL ARM - COMPLETE</b>	537140	1
1	CAST IRON HORIZONTAL-MECHANICAL PROCESSI	542631-1	1
2	MOUNTING RING 2	537141	1
3	MOUNTING RING 1	537139	2
4	SCREW M6X25 HSFH ZC 8.8 DIN7991	F81001-68	8
5	STICKER-SCALE 1	537142	1
6	INDICATOR, SCALE 2	537148	1
7	WASHER 6.4 FE/ZN5 PN-78/M-82005	F81053-1	1
8	BOLT, M6X12 8.8 HEX HEAD FULL THREAD ZIN	F81001-7	1

### 3.5 Spindle Housing (No. 537153)

537153-001  
537153-MANUAL

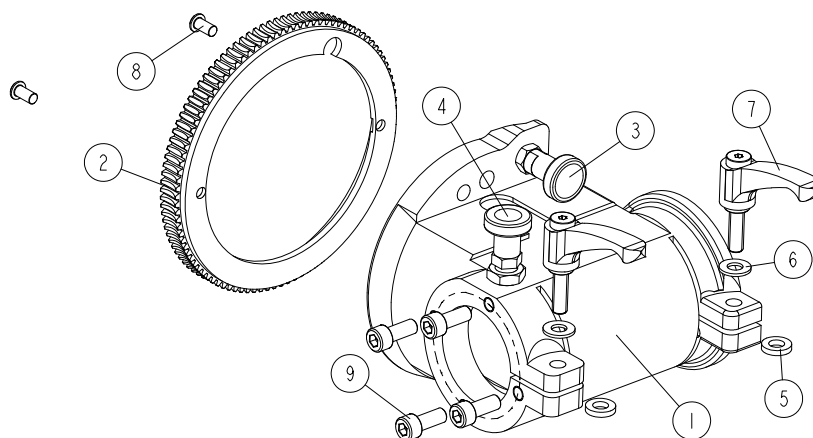

REF	DESCRIPTION (u indicates parts available in assemblies only)	PART #	QTY
-	<b>HOUSING, SPINDLE CAST IRON - COMPLETE</b>	537153	1
1	HOUSING, SPINDLE CAST IRON	546842-1	1
2	WORM GEAR	330-259-2	1
3	PLUNGER, M6X20 GN 617.1-6-A INDEXING	537154	1
4	PLUNGER, M6X20 GN 617-6-AK INDEXING	537184	1
5	WASHER, 8.4/16-3	537156-1	2
6	WASHER, 8.4 FLAT ZINC	F81054-1	2
7	ADJUSTABLE HANDLE, ERZ.63P-M8X25	533591	2
8	SCREW, M6X12 10.9 FE/ZN5 BN 1206 HEX SOC	F81001-105	2
9	SCREW, M8X20-8.8 HEX SOCKET HEAD CAP ZIN	F81002-30	4

### 3.6 Up/Down Assembly (No. 537130)

537130\_001\_A  
537130\_MANUAL

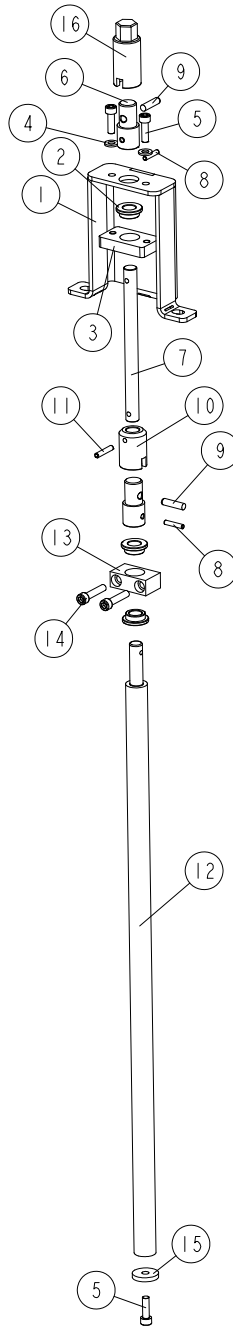

REF	DESCRIPTION (u indicates parts available in assemblies only)	PART #	QTY
-	UP/DOWN ASSEMBLY	537130	1
1	BRACKET	537121-1	1
2	BUSHING, 12/18-8 FLANGED 24-3	546901	3
3	BLOCK	537127-1	1
4	WASHER 6.4 FE/ZN5 PN-78/M-82005	F81053-1	2
5	SCREW, M6X20 8.8 HEX SOCKET HEAD CAP ZIN	F81001-22	3
6	PIN, SCALE DISK MOUNT	533595-1	2

REF	DESCRIPTION (u indicates parts available in assemblies only)	PART #	QTY	
7	ROD, ADJUSTMENT	537128-1	1	
8	PIN, PN-EN ISO 8752-4X20-ST-A0P SPRING-T	F81044-11	2	
9	DOWEL PIN 6M6X12 DIN 7 ISO 2338	F81045-5	2	
10	CONNECTOR	537129-1	1	
11	PIN, 4X24 ZINC-PLATED SPRING TYPE	F81044-13	1	
12	SCREW, TR20X4 LONG ACME	537131	1	
13	BLOCK, MOUNT	537136-1	1	
14	SCREW, M6X30-8.8 HEX SOCKET HEAD CAP ZIN	F81001-42	2	
15	WASHER 6.5/24-4 ZINC	537195-1	1	
16	FITTING	561829-1	1	

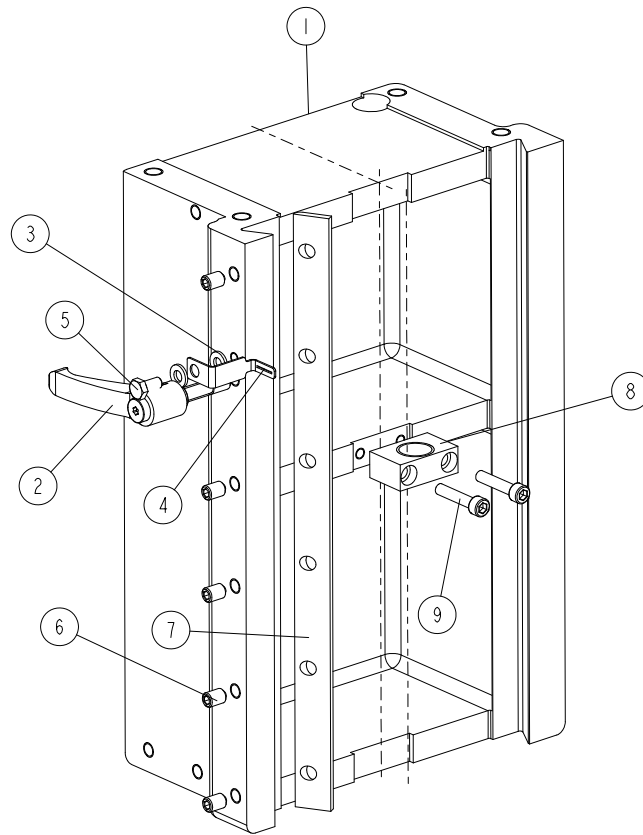

## 3.7 Vertical Arm 2 (No. 537171)

537171\_001\_A  
537171\_MANUAL

Ref	DESCRIPTION (* indicates parts available in assemblies only)	PART #	QTY
-	<b>VERTICAL ARM 2 - COMPLETE</b>	537171	1
1	CAST IRON VERTICAL 2-MECHANICAL PROCESSING	542630-1	1
2	ADJUSTABLE HANDLE ERZ.63 P-M8X32	537149	1
3	WASHER 6,4 ZC DIN 126 ISO 7091	F81053-1	2
4	INDICATOR, SCALE 1	537144	1
5	BOLT M6X12 HH ZC FT 8.8 DIN 933	F81001-7	1
6	SCREW M8X12 HSS W/CONE POINT ZC 45H DIN 914	F81002-105	5
7	SIDESLIP 2	537172	1
8	MOUNTING BLOCK 2	537173-1	1
9	SCREW M6X30 SHCS ZC 8.8 DIN 912 ISO 4762	F81001-42	2

### 3.8 Spindle In/Out Setting Assembly (Part No. 537174)

537174\_001\_A  
537174\_MANUAL

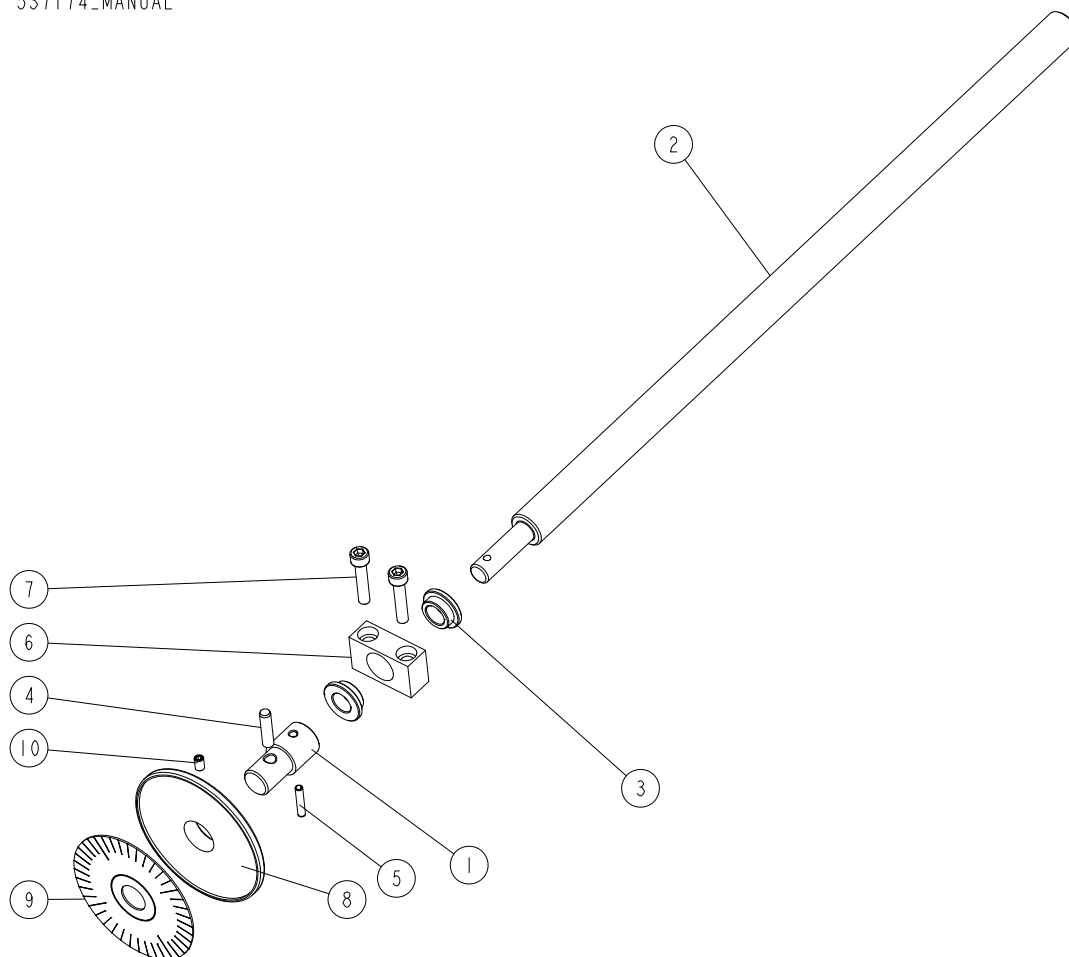

REF.	DESCRIPTION (* indicates parts available in assemblies only)	PART #	QTY
-	<b>SPINDLE IN/OUT SETTING ASSEMBLY</b>	537174	1
1	PIN, SCALE DISK MOUNT	533595-1	1
2	SCREW, TR20X4 SHORT ACME	537175	1
3	BUSHING, 12/18-8 FLANGE 24-3	546901	2
4	PIN, ISO2338- 6M6X24-A1 DOWEL	F81045-5	1
5	PIN, PN-EN ISO 8752-4X20-ST-A0P SPRING-TYPE	F81044-11	1
6	BLOCK, MOUNT	537136-1	1
7	SCREW, M6X30-8.8 HEX SOCKET HEAD CAP ZINC	F81001-42	2
8	DISK, ROUND SCALE	533594	1
9	DECAL, MP200 ROUND SCALE	533577	1
10	SCREW, M5X8 45H DIN 913 HEX SOCKET SET W/FLAT POINT	F81014-7	1

## 3.9 Worm Shaft Assembly (No. 537180)

537180\_001\_MF  
537180\_MANUAL

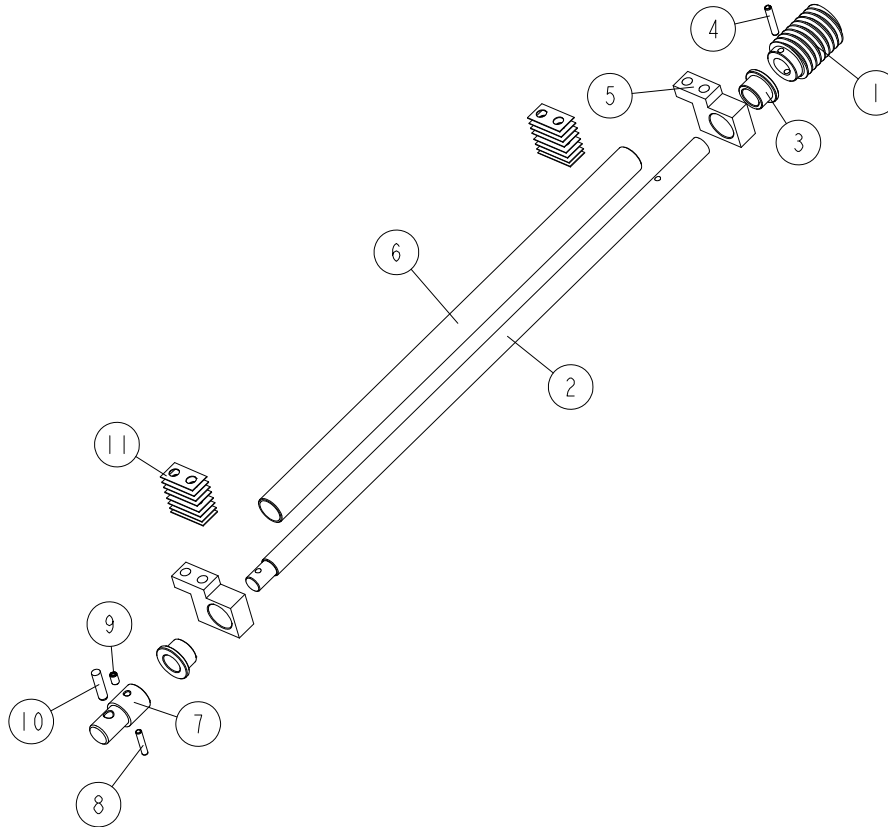

REF	DESCRIPTION (u indicates parts available in assemblies only)	PART #	QTY	
-	<b>WORM SHAFT ASSEMBLY</b>	537180	1	
1	WORM	537177	1	
2	SHAFT, WORM	537178	1	
3	BUSHING, 14/20-14 FLANGE 26-3	546905	2	
4	PIN, 4X24 ZINC-PLATED SPRING TYPE	F81044-13	1	
5	BLOCK 2	537179-1	2	
6	COVER	537182-1	1	
7	PIN, SCALE DISK MOUNT	533595-1	1	
8	PIN, PN-EN ISO 8752-4X20-ST-A0P SPRING-T	F81044-11	1	
9	DISK, ROUND SCALE	537176	1	
10	SCREW, M5X8 45H DIN 913 HEX SOCKET SET W	F81014-7	1	
11	DECAL, MP200 ROUND SCALE	537183	1	
12	DOWEL PIN 6M6X12 DIN 7 ISO 2338	F81045-5	1	
13	PLATE	537661	16	

### 3.10 Handle Assembly (No. 542521)

542521\_001  
542521\_MANUAL

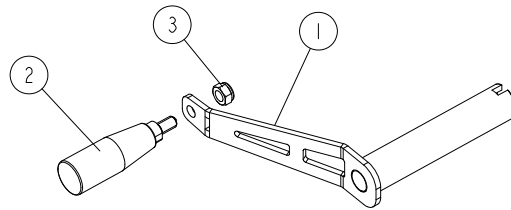

REF.	DESCRIPTION (* indicates parts available in assemblies only)	PART #	QTY	
-	<b>HANDLE, COMPLETE</b>	542521	1	
1	HANDLE	542522-1	1	
2	GRIP, CYLINDRICAL	533505	1	
3	NUT, M8-8-B HEX NYLON ZINC LOCK	F81032-2	1	

### 3.11 Spindle w/Drive Box & Guard (No. 537635)

537635\_001  
537635\_MANUAL

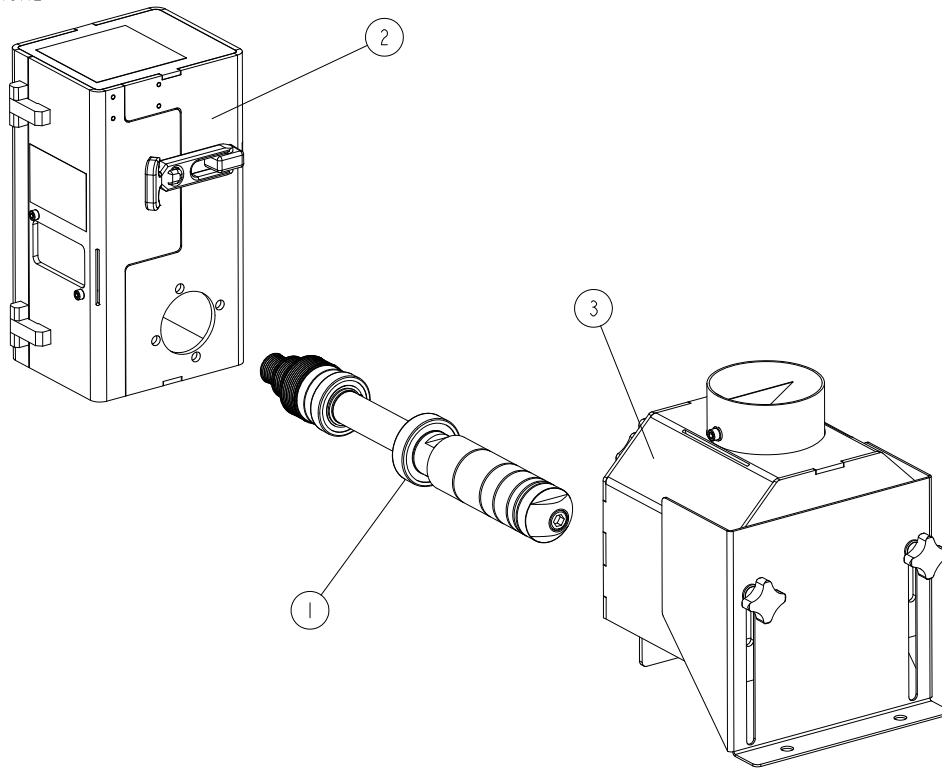

REF.	DESCRIPTION (* indicates parts available in assemblies only)	PART #	QTY
-	<b>SPINDLE W/DRIVE BOX &amp; GUARD</b>	537635	1
1	SPINDLE ASSEMBLY <a href="#">See Section 3.12</a>	537630	1
2	BOX, DRIVE - COMPLETE <a href="#">See Section 3.13</a>	537610	1
3	GUARD, CUTTER - COMPLETE <a href="#">See Section 3.14</a>	537120	1

### 3.12 Spindle Assembly (No. 537630)

537630\_001  
537630\_MANUAL

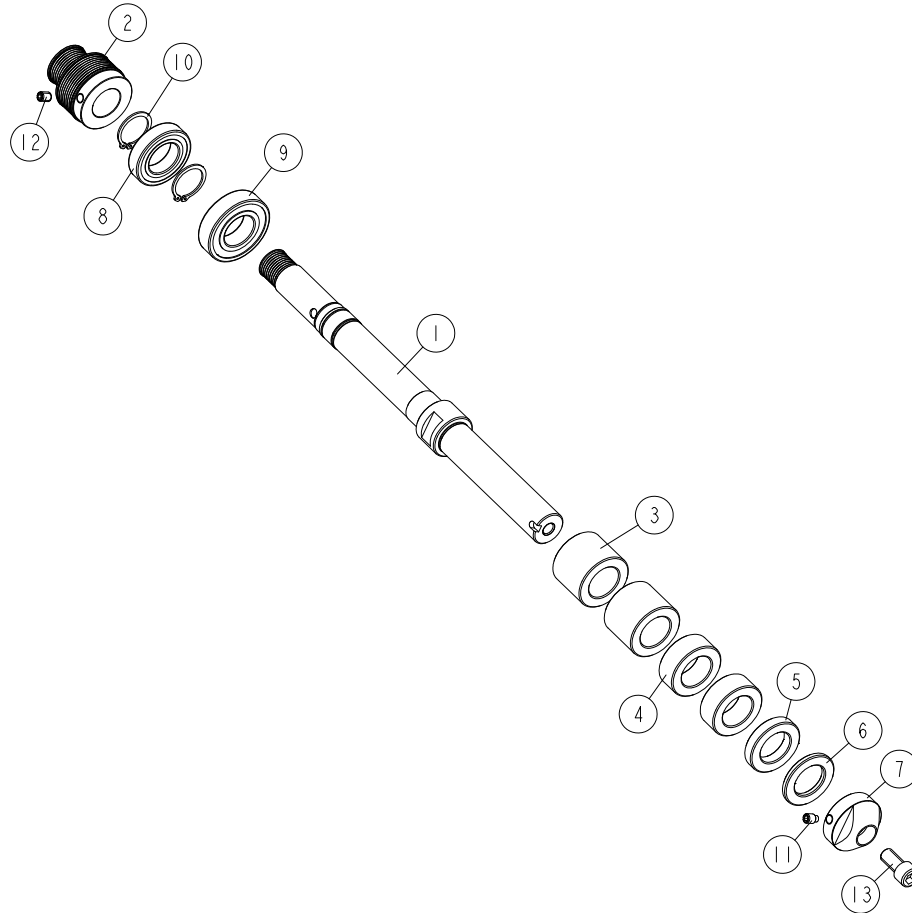

REF	DESCRIPTION (u indicates parts available in assemblies only)	PART #	QTY
-	<b>SPINDLE ASSEMBLY</b>	537630	1
1	SPINDLE	537626	1
2	SHEAVE, MULTI-GROOVE	537624	1
3	BUSHING, N30/N50-40	537627-1	2
4	BUSHING, N30/N50-20	537628-1	2
5	BUSHING, N30/N50-10	537629-1	1
6	BUSHING, N30/N50-5	537631-1	1
7	BUSHING, N13/N50-28 SPECIAL	537625-1	1
8	BEARING, 6006 2RSR	096191	1
9	BEARING, 6206 2RSR P6 ROLLING (FAG, NSK,	100787	1
10	RING, Z30 SPRING RETAINING	F81090-23	2
11	SCREW, M8X12-45H- PN-EN-ISO 4028 ; DIN91	F81002-122	1
12	SCREW, M8X10-45H DIN913 HEX SOCKET SET W	F81002-123	1
13	SCREW, M12X25-12.9 HEX SOCKET HEAD CAP Z	F81004-120	1

### 3.13 Drive Box (Part No. 537610)

537610\_001  
537610\_MANUAL

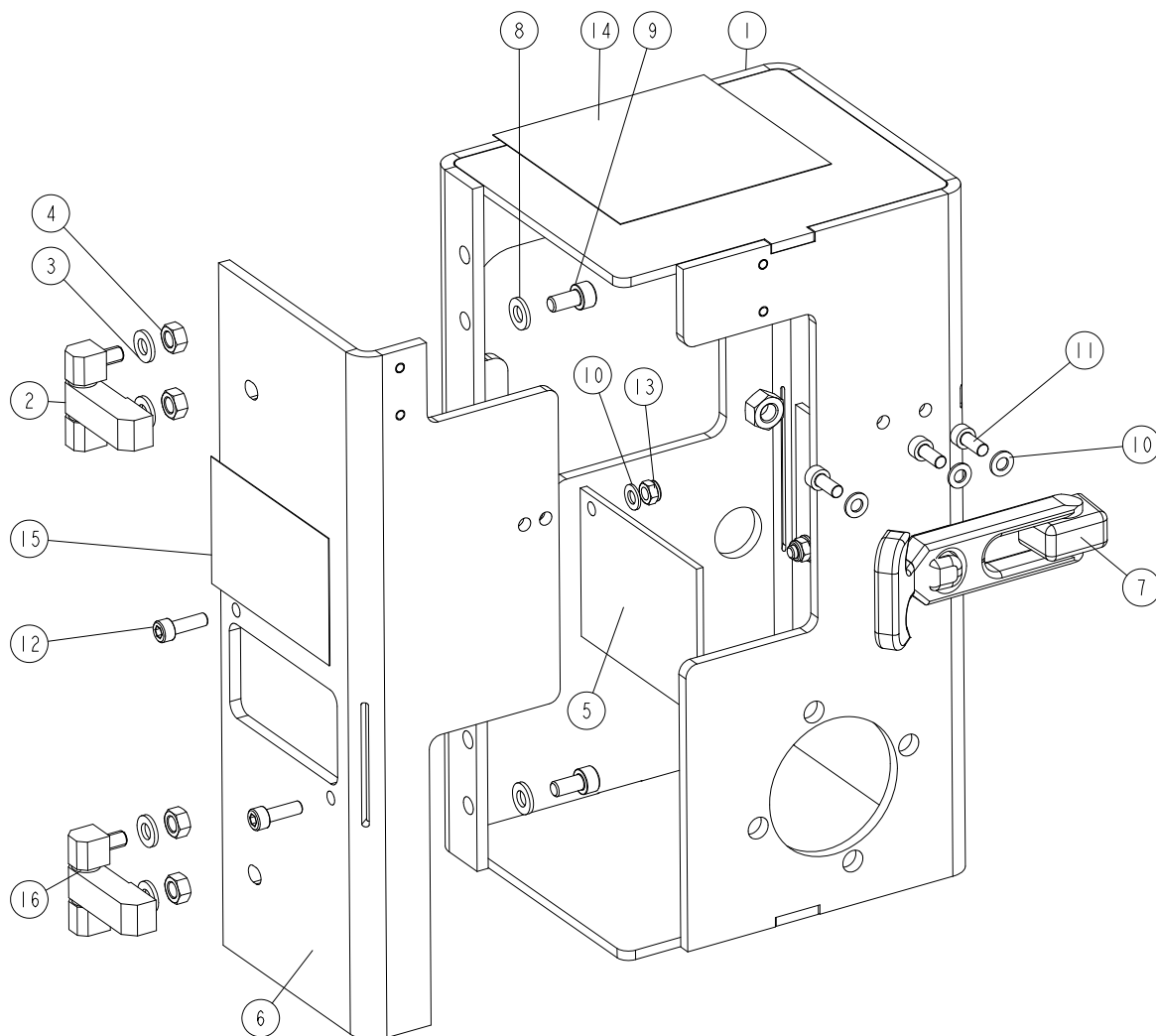

REF	DESCRIPTION (u indicates parts available in assemblies only)	PART #	QTY
-	<b>BOX, DRIVE - COMPLETE</b>	537610	1
1	BOX, DRIVE	537615-1	1
2	HINGE K1143.0630028 (KIPP)	537616	2
3	WASHER 6.4 FE/ZN5 PN-78/M-82005	F81053-1	2
4	NUT, M6-8 HEX ZINC	F81031-1	2
5	PLATE, INSPECTION WINDOW	537619	2
6	PLATE, DOOR	537611-1	1
7	SELF-ADJUSTING LATCH SOUTHCO NR ART.258-	537617	1
8	WASHER 6.4 FE/ZN5 PN-78/M-82005	F81053-1	2
9	SCREW M6X12 SHCS ZC 8.8 DIN 912 ISO 4762	F81001-87	2
10	WASHER, M5, FLAT ZINC	F81052-1	7
11	SCREW M5X12 SHCS ZC 8.8 DIN 912 ISO 4762	F81000-53	3
12	SCREW, M5X16-8.8 HEX SOCKET HEAD CAP ZIN	F81000-25	4
13	NUT, M5-8-FE/ZN5 DIN985	F81030-2	4

REF	DESCRIPTION (u indicates parts available in assemblies only)	PART #	QTY	
14	DECAL 1	537614	1	
15	DECAL	537618	1	
16	WASHER	542519	4	

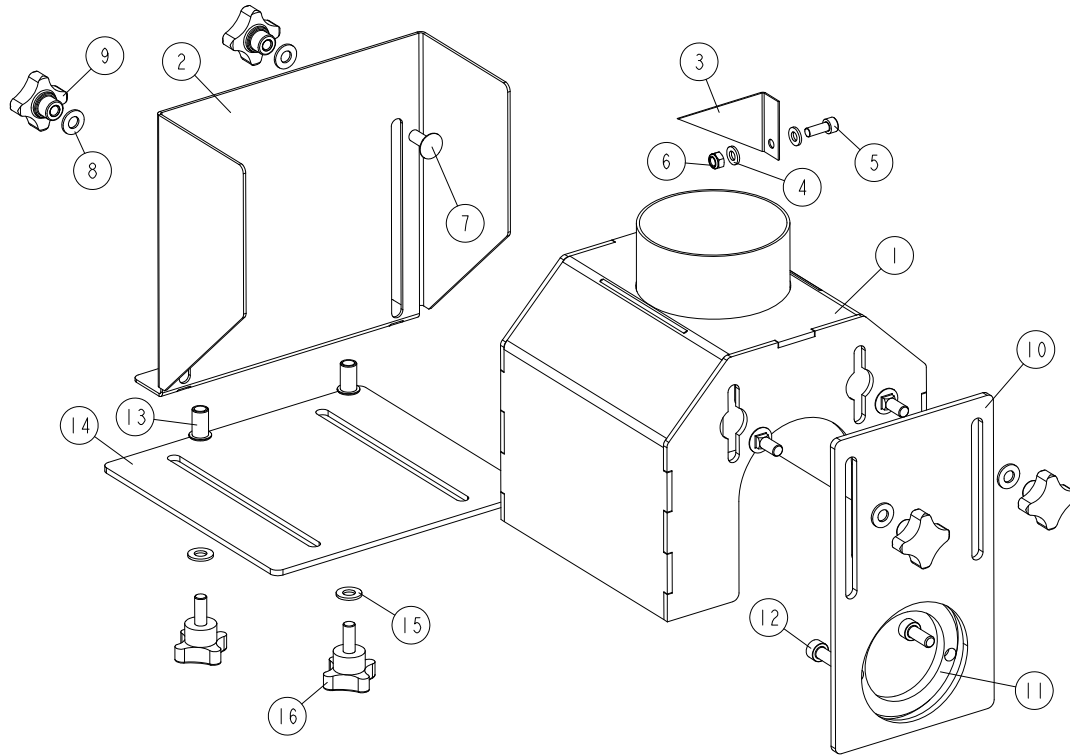

## 3.14 Cutter Guard (No. 537120)

537120\_001  
537120\_MANUAL

REF	DESCRIPTION (u indicates parts available in assemblies only)	PART #	QTY
-	<b>GUARD, CUTTER - COMPLETE</b>	537120	1
1	GUARD WELDMENT	537105-1	1
2	PLATE, ADJUSTMENT (1)	537104-1	1
3	PLATE, CHIP DUCT	534179	1
4	WASHER, M6, FLAT,ZINC	F81053-1	2
5	SCREW, M6X16 -8.8 HEX SOCKET HEAD CAP ZI	F81001-21	1
6	NUT, M6-8-B NYLON HEX ZINC LOCK	F81031-2	1
7	BOLT M8X20 CARRIAGE ZC 8.8 DIN603 ISO 86	F81002-121	4
8	WASHER, 8.4 FLAT,ZINC	F81054-1	4
9	PALM GRIP	537110	4
10	PLATE, ADJUSTMENT (2)	537112-1	1
11	RING, MOUNTING	537113-1	1
12	SCREW, M8X20-8.8 HEX SOCKET HEAD CAP ZIN	F81002-30	2
13	NUT, M8 1.0-2.5 FTR-Z FE/ZN5 RIVET	F81032-9	2
-	PLATE ASSY, LOWER	542520	1
14	PLATE, LOWER	542518-1	1
15	WASHER, 8.4 FLAT,ZINC	F81054-1	2
16	KNOB, 50/M8X25 (466406 MOSS)	500973	2

**3.15 Equipment for Curved Moulding (No. 546831)**

546831\_001  
546831\_MANUAL

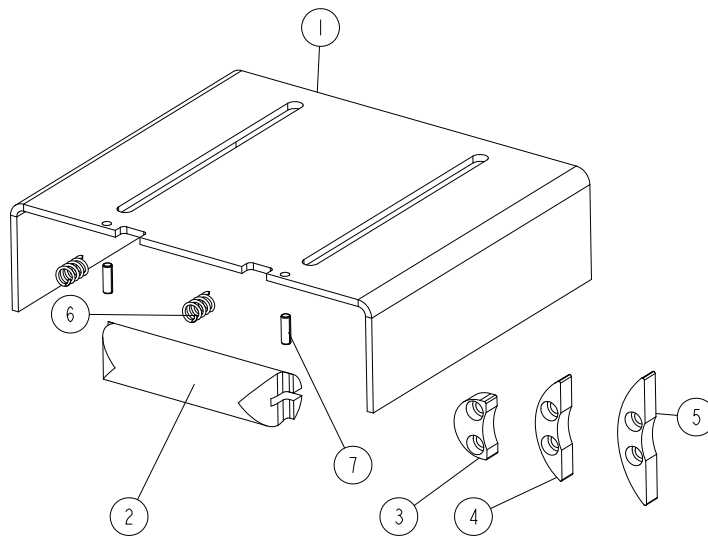

REF	DESCRIPTION (u indicates parts available in assemblies only)	PART #	QTY
-	<b>EQUIPMENT FOR CURVED MOULDING</b>	546831	1
1	PLATE, 64X234X200	330-906-W-1	1
2	SHAFT, 30	547206	1
3	SPRING, 10.7X1.5X19	542476	2
4	PIN, 5X16 ROLL ZINC	F81044-3	2

### 3.16 Short Spindle (No. 546823)

546823\_001  
546823\_MANUAL

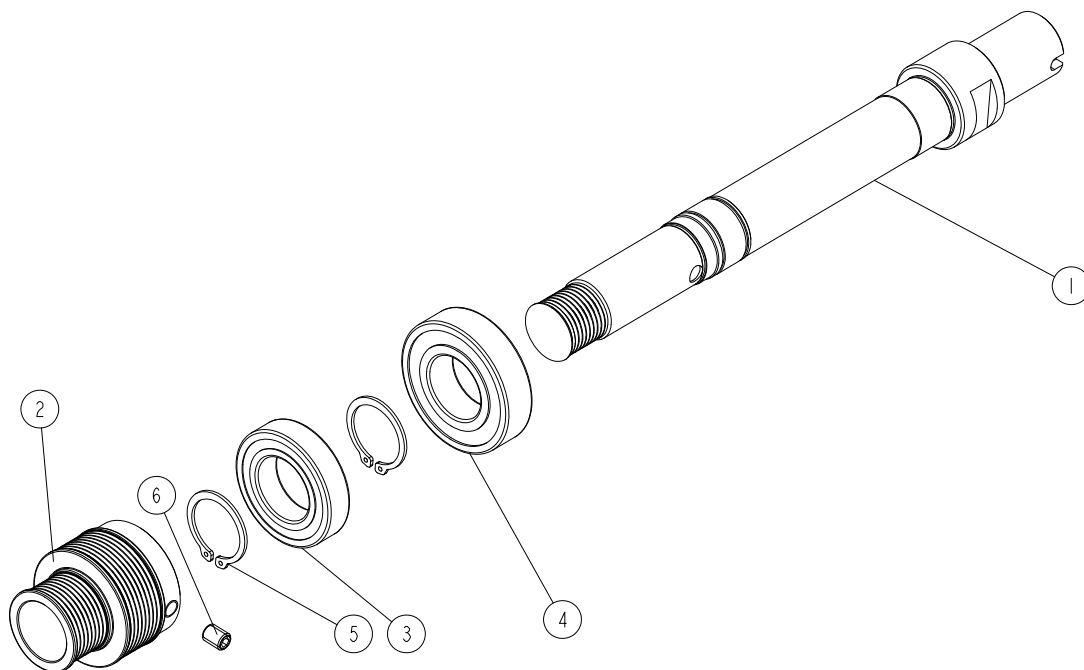

REF.	DESCRIPTION (* indicates parts available in assemblies only)	PART #	QTY
-	<b>SPINDLE, 40mm SHORT - COMPLETE</b>	546823	1
1	SPINDLE, 40MM SHORT	541434	1
2	SHEAVE, MULTI-GROOVE	537624	1
3	BEARING, 6006 2RSR	096191	1
4	BEARING, 6206 2RSR P6 ROLLING (FAG, NSK, SKF)	100787	1
5	RING, Z30 OUTSIDE RETAINING	F81090-23	2
6	SCREW, M8X10-45H DIN913 HEX SOCKET SET W/FLAT POINT	F81002-123	1

## 3.17 Guard for Side Spindle in Vertical Position (No. 542465)

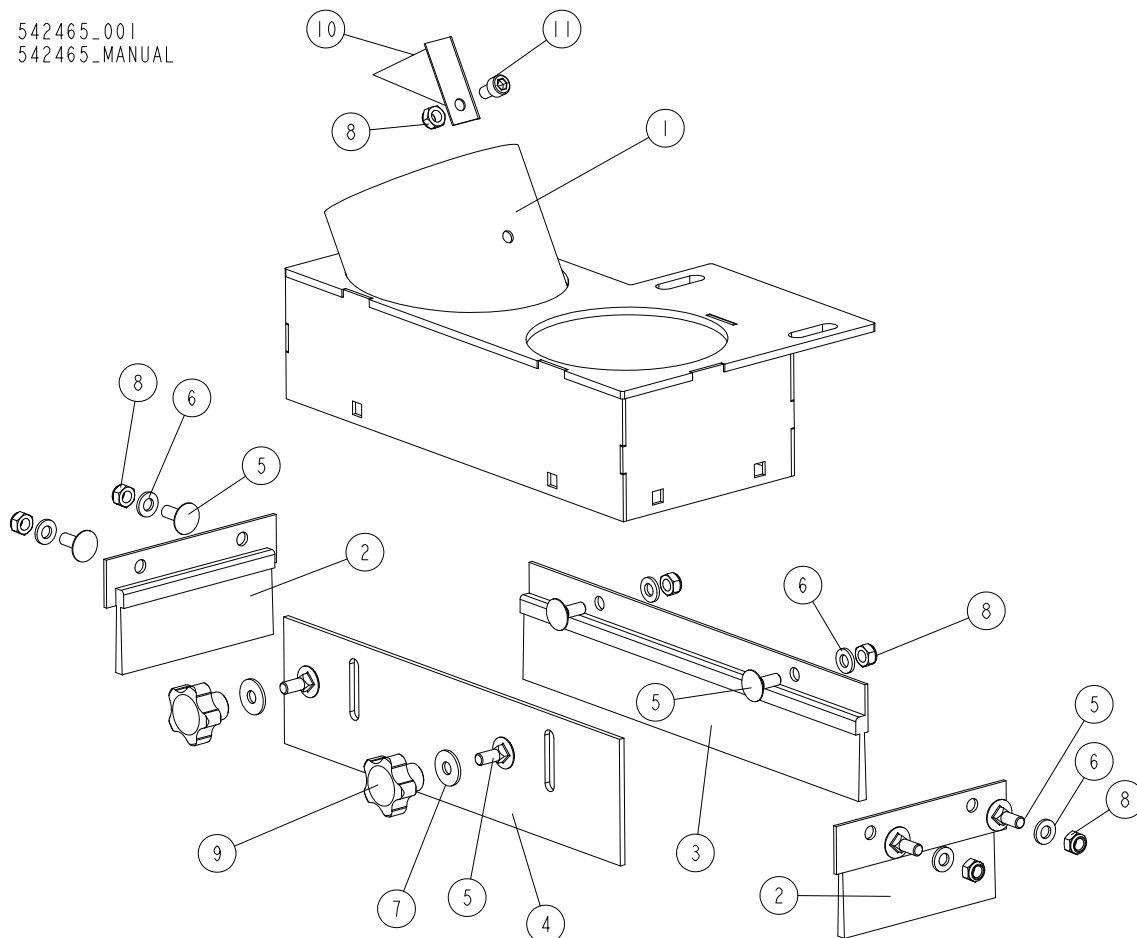
542465-001  
542465-MANUAL

REF.	DESCRIPTION (* indicates parts available in assemblies only)	PART #	QTY
-	<b>OSŁONA GŁOWICY FREZUJĄCEJ DO TRZPIENI</b>	542465	1
1	GUARD WELDMENT	542464-1	1
2	SEAL, H5 35MM BRUSH	542467	2
3	SEAL, H5 35MM BRUSH	542466	1
4	COVER	542468	1
5	BOLT, M6X16-8.8 CARRIAGE ZINC	F81001-36	8
6	WASHER, 6.4 FLAT ZINC	F81053-1	6
7	WASHER, 6.5 SPECIAL FLAT ZINC	F81053-11	2
8	NUT, M6-8-B HEX NYLON ZINC LOCK	F81031-2	7
9	KNOB, VC.692/32 B-M6	542469	2
10	PLATE, CHIP DUCT	534179	1
11	SCREW, M6X10 8.8 HEX SOCKET HEAD CAP ZINC	F81001-12	1

## 3.18 Guard for Side Spindle in Horizontal Position (No. 542480)

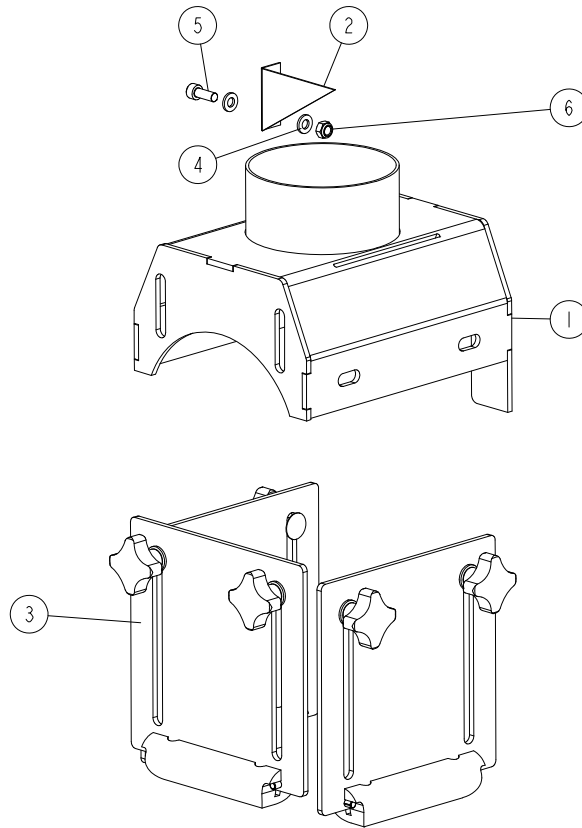
542480\_001  
542480\_MANUAL

REF.	DESCRIPTION (* indicates parts available in assemblies only)	PART #	QTY
-	<b>GUARD, SIDE SPINDLE IN HORIZONTAL POSITION</b>	542480	1
1	GUARD WELDMENT	542475-1	1
2	PLATE, CHIP DUCT	534179	1
3	PLATE, COMPLETE SIDE <a href="#">See Section 3.19</a>	542477	3
4	WASHER, 6.4 FLAT ZINC	F81053-1	2
5	SCREW, M6X16 8.8 HEX SOCKET HEAD CAP ZINC	F81001-21	1
6	NUT, M6-8-B HEX NYLON ZINC LOCK	F81031-2	1

### 3.19 Side Plate (No. 542477)

542477\_001  
542477\_MANUAL

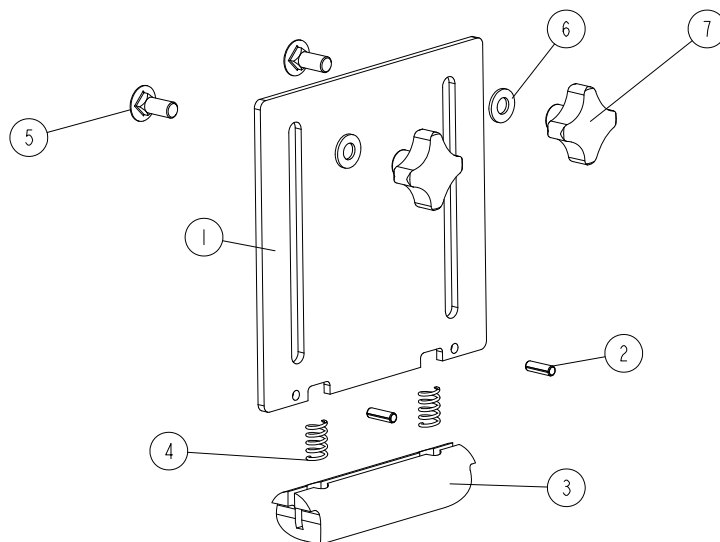

REF.	DESCRIPTION (* indicates parts available in assemblies only)	PART #	QTY
-	<b>PLATE, COMPLETE SIDE</b>	542477	1
1	PLATE, SIDE	542474-1	1
2	PIN, 5X16 ROLL ZINC	F81044-3	2
3	SHAFT, 30	547206	1
4	SPRING, 10.7X1.5X19	542476	2
5	BOLT, M8X20-8.8 CARRIAGE ZINC	F81002-121	2
6	WASHER, 8.4 FLAT ZINC	F81054-1	2
7	GRIP, KIPP K0148.308 PALM	537110	2

## SECTION 4 MOTOR & ELECTRICAL BOX

### 4.1 Motor & Electrical Box

544335\_001  
544335\_MANUAL

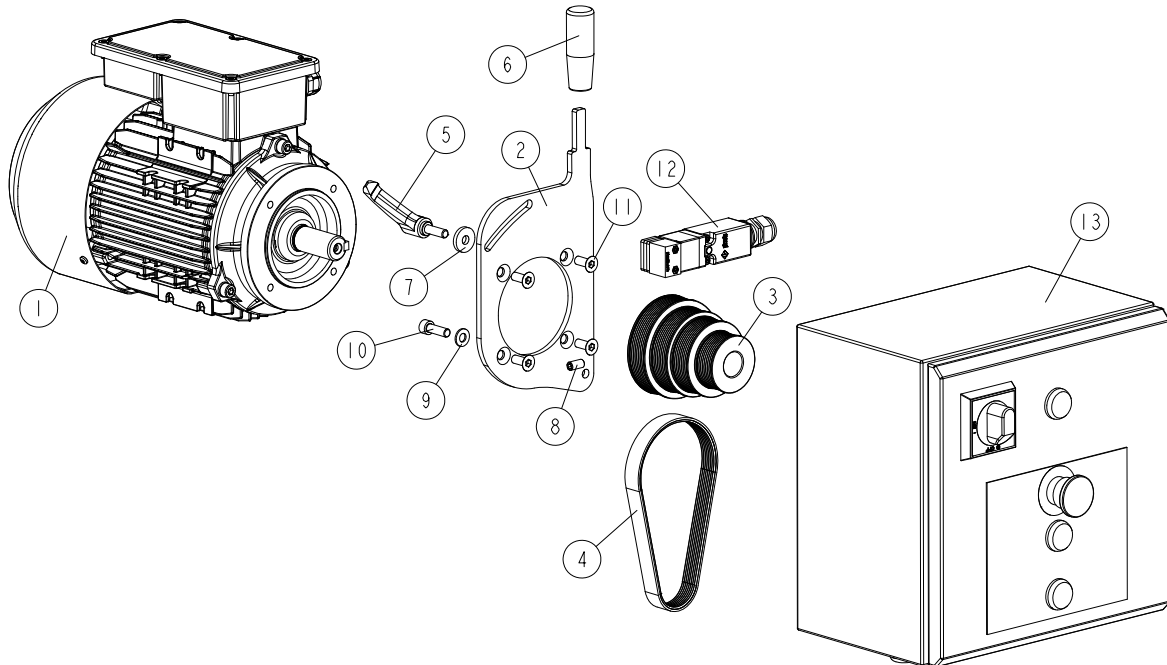

REF	DESCRIPTION (u indicates parts available in assemblies only)	PART #	QTY
-	<b>MOTOR &amp; ELECTRICAL BOX</b>	544335	1
-	<b>MOTOR &amp; ELECTRICAL BOX MF130EH3</b>	544335-3	1
-	<b>MOTOR &amp; ELECTRICAL BOX MF130EB3</b>	544335-5	1
-	<b>MOTOR &amp; ELECTRICAL BOX MF130EA3</b>	544335-8	1
1	MOTOR 3SIEK 90L-2A-HM 3KW IM3601 B14 <sup>1</sup>	536947	1
-	MOTOR 3SIEK90L2A, B14/C140, 3KW, 2900 R. <sup>2</sup>	537385	1
-	MOTOR 3SIEK90L2A, B14/C140, 3KW, 2900 R. <sup>3</sup>	537385	1
-	MOTOR SELHR90-2M2 IMB34/2 2,7KW 230V <sup>4</sup>	533651	1
2	MOTOR PLATE <sup>1</sup>	546367-1	1
-	MOTOR PLATE MP365 <sup>2 3 4</sup>	537301-1	1
3	PULLEY MULTI-GROVE	537632	1
4	BELT, 8 PJ 457 MULTI-RIBBED	533680	1
5	HANDLE, ADJUSTABLE ERZ.63 P-M8X25	546406	1
6	HANDLE 1.580/80 N-12	537302	1
7	WASHER 8.5/24-4 ZINC	537362-1	1
8	SCREW M8X16 HSS W/FLAT POINT ZC 45H DIN	F81002-124	1
9	WASHER, 8.4 FLAT ZINC	F81054-1	1
10	SCREW, M8X25 8.8 HEX SOCKET HEAD CAP ZIN	F81002-21	1
11	BOLT, M8X20-10.9 DIN7991 ZINC-PLATED <sup>1</sup>	F81002-113	4
-	BOLT, M8X20-10.9 DIN7991 ZINC-PLATED <sup>2 3 4</sup>	F81002-113	4
12	SWITCH ASSEMBLY, SAFETY (3) <a href="#">See Section 4.2</a>	537620	1
13	BOX, MF130 ELECTRICAL - COMPLETE <sup>1 2</sup> <a href="#">See Section 4.3</a>	536939	1

**4****MOTOR & ELECTRICAL BOX***Motor & Electrical Box*

---

REF	DESCRIPTION (u indicates parts available in assemblies only)	PART #	QTY	
-	BOX, MF130EB ELECTRICAL - COMPLETE <sup>3</sup> <a href="#">See Section 4.3</a>	536939-2	1	
-	BOX, MF130EA ELECTRICAL - COMPLETE <sup>4</sup> <a href="#">See Section 4.3</a>	536939-6	1	

<sup>1</sup> Included in MF130EH3S

<sup>2</sup> Included in MF130EH3

<sup>3</sup> Included in MF130EB3

<sup>4</sup> Included in MF130EA3



4.2 Safety Switch Assembly (3)

537620\_001  
537620\_MANUAL

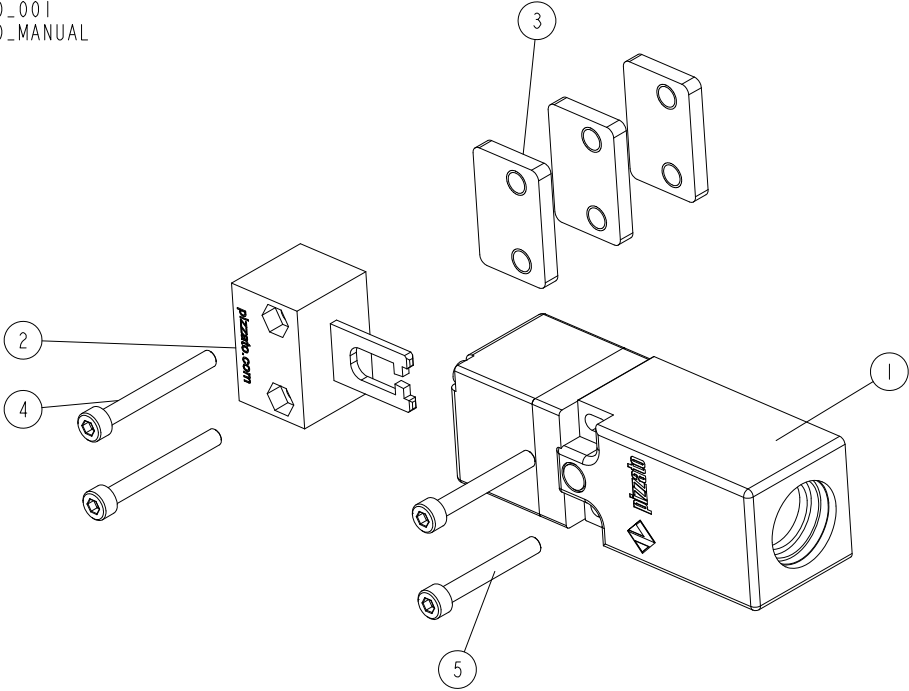

REF.	DESCRIPTION (* indicates parts available in assemblies only)	PART #	QTY
-	<b>SWITCH ASSEMBLY, SAFETY (3)</b>	537620	1
1	SWITCH, FR 693-M2 SAFETY	537623	1
2	KEY- VF KEYD3	537622	1
3	PLATE	537621-1	3
4	SCREW, M4X35 8.8 HEX SOCKET HEAD CAP ZINC	F81011-34	2
5	SCREW, M4X30-8.8 DIN 912 ISO 4762 HEX SOCKET HEAD CAP ZINC	F81000-85	2

## 4.3 Electrical Box (No. 536939)

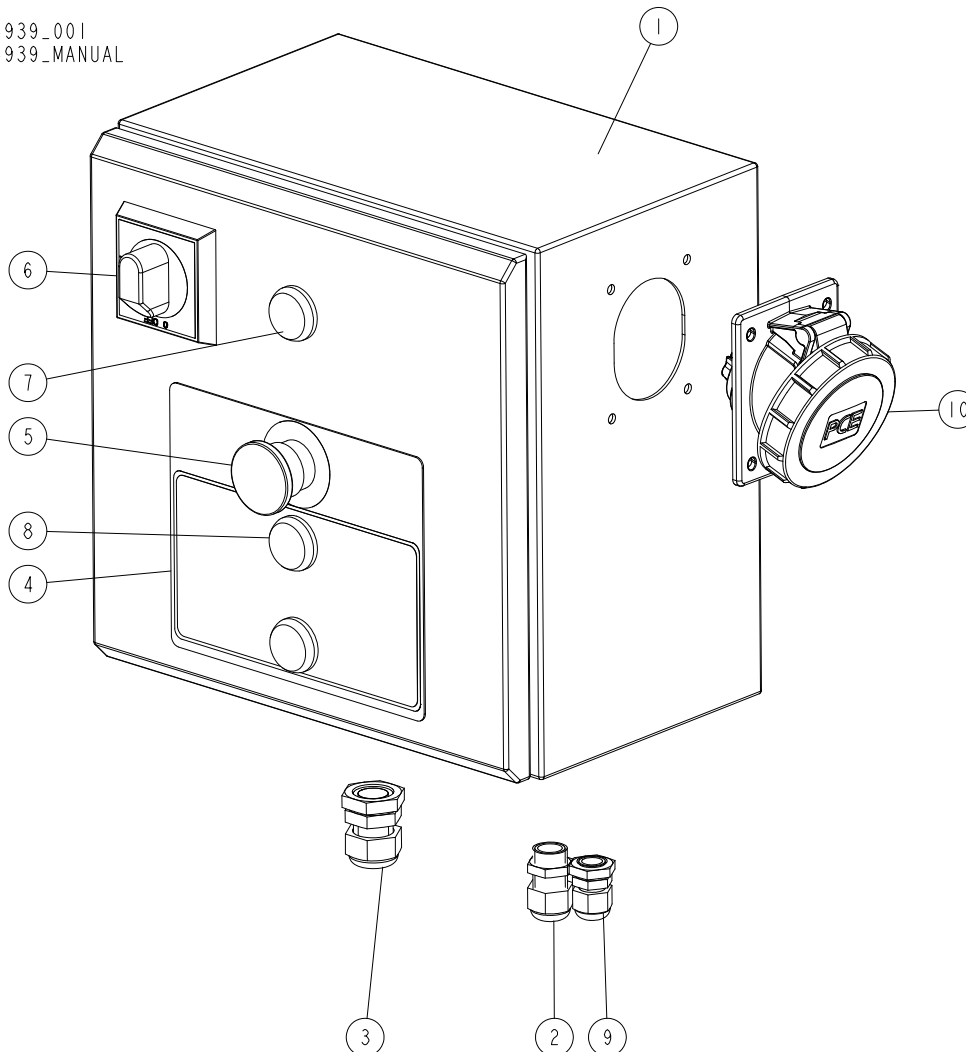
536939\_001  
536939\_MANUAL

REF.	DESCRIPTION (* indicates parts available in assemblies only)	PART #	QTY
-	<b>BOX, MF130 ELECTRICAL - COMPLETE</b>	536939	1
1	BOX, MF130 ELECTRICAL	541451	1
2	GLAND, DW11/H CABLE	085388	1
3	GLAND, DP16/H CABLE	F81096-7	1
4	DECAL, MF130 ELECTRICAL BOX	553802	1
5	SWITCH, XB4 BS542 EMERGENCY STOP	086556	1
6	HANDLE, ABB SWITCH	088265-1	1
7	LIGHT, M22 LED 24V BLUE CONTROL	090448	1
8	LIGHT, M22 LED 24V BLUE CONTROL	541452	2
9	GLAND, DP9/H CABLE	F81096-2	1
10		4152-6F78	1

## SECTION 5 XY TABLE (OPTION)

### 5.1 XY TABLE (Option). 546841

546841\_001\_A  
 546841\_MANUAL

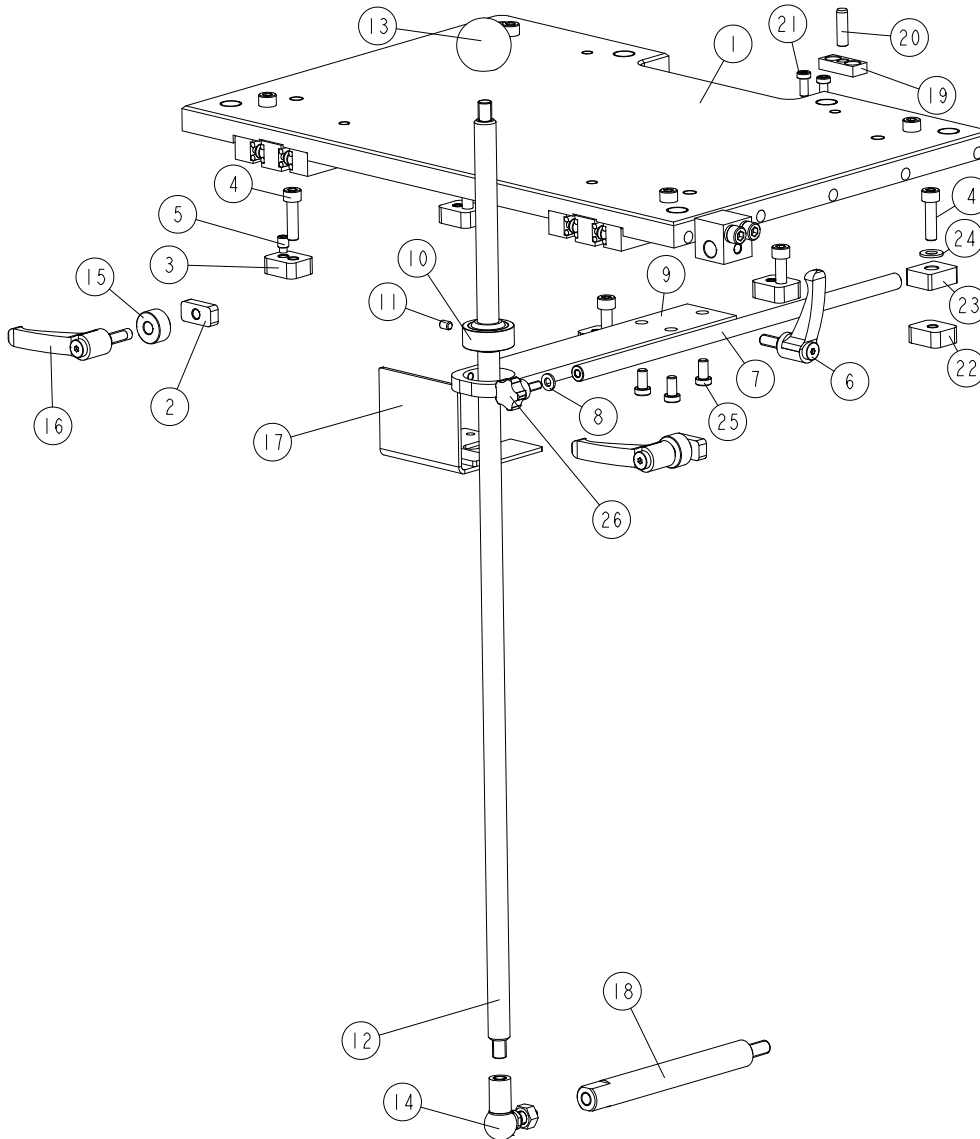

REF	DESCRIPTION (◆ indicates parts available in assemblies only)	PART #	QTY
-	X=Y TABLE TO MOUNTED ON THE SLIDING TABL	546841	1
1	PLATE COMPLETE <a href="#">See Section 5.2</a>	541422	1
2	PLATE 2	541403-1	2
3	PLATE 3	541406-1	4
4	BOLT, M8 X 30-8.8 SOCKET HEAD	F81002-31	5
5	SCREW M8X12 HSS W/DOG POINT ZC 45H DIN 9	F81002-122	4
6	ADJUSTABLE HANDLE ERZ.63 P-M8X20	534378	1
7	ROD FI12	541411-1	1
8	WASHER, 6.4 FLAT ZINC	F81053-1	1
-	BLOCK PIVOT COMPLETE	541415	1



## XY TABLE (OPTION)

XY TABLE (Option). 546841

REF	DESCRIPTION (◆ indicates parts available in assemblies only)	PART #	QTY	
9	BLOCK PIVOT	541413-1	1	
10	BEARING PIVOT SLIDE 16X38X15	541414	1	
11	SCREW M6X8	F81013-1	1	
-	ROD 2 COMPLETE	541418	1	
12	ROD F116	541416-1	1	
13	KNOB M10 ROUND	541417	1	
14	JOINT BALL ANGLE M10	541419	1	
15	SPACER 1	541402-1	2	
16	HANDLE ERZ.63 M8X25 ADJUSTABLE}	541407	2	
17	ANGLE WLDMT	541410-1	1	
18	PIN 2	541400-1	1	
19	PLATE 1	541401-1	1	
20	PIN ROLL H 8H6X28 DIN6325 HRC60	F81048-4	1	
21	SCREW, M6X16-10.9 DIN 7984	F81001-107	2	
22	PLATE 3	541404-1	1	
23	PLATE 3	541405-1	1	
24	WASHER, 8.4 FLAT ZINC	F81054-1	1	
25	BOLT DIN7984-M8X16-10.9 HEX LOWERED HEAD	F81002-118	3	
26	KNOB STAR DIA25/M6X16	541412	1	

## 5.2 Complete Plate. 541422

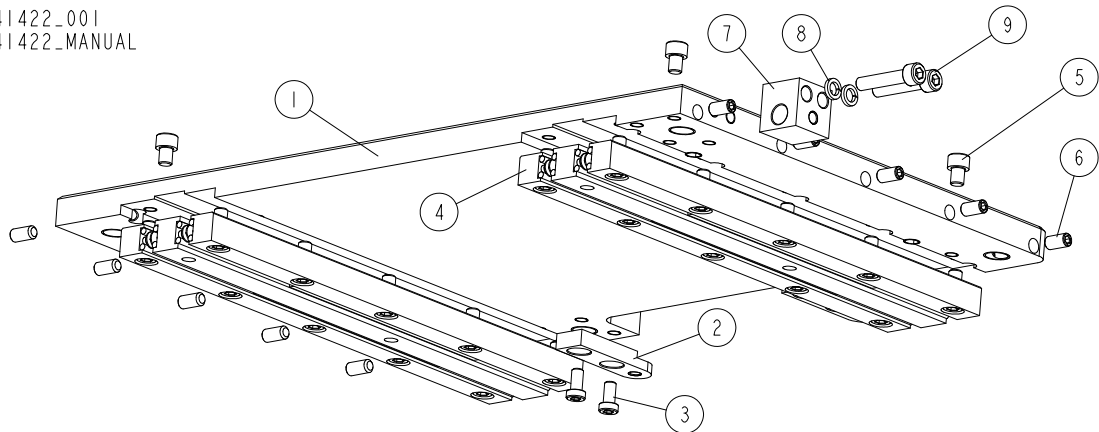
541422-001  
541422-MANUAL

REF	DESCRIPTION (◆ indicates parts available in assemblies only)	PART #	QTY	
-	PLATE COMPLETE	541422	1	
1	PLATE MAIN	541420-1	1	
2	LINK 1	541421-1	2	
3	BOLT DIN7984-M8x16-10.9 HEX LOWERED HEAD	F81002-118	4	
4	GUIDES TABLE <a href="#">See Section 5.3</a>	546487	1	
5	SCREW,M8X10-8.8-FE/ZN5 HEX SOCKET HEA	F81002-32	4	
6	SCREW,M8X16-33H HEX SOCK. FLAT POINT SET	F81014-2	10	
7	BLOCK 1	541429-1	1	
8	WASHER 8,2 FE/ZN9	F81054-4	2	
9	SCREW, M8X40-8.8 HEX SOCKET HEAD CAP ZIN	F81002-29	2	

### 5.3 Table Guides. 546487

546487\_001\_A  
546487\_MANUAL

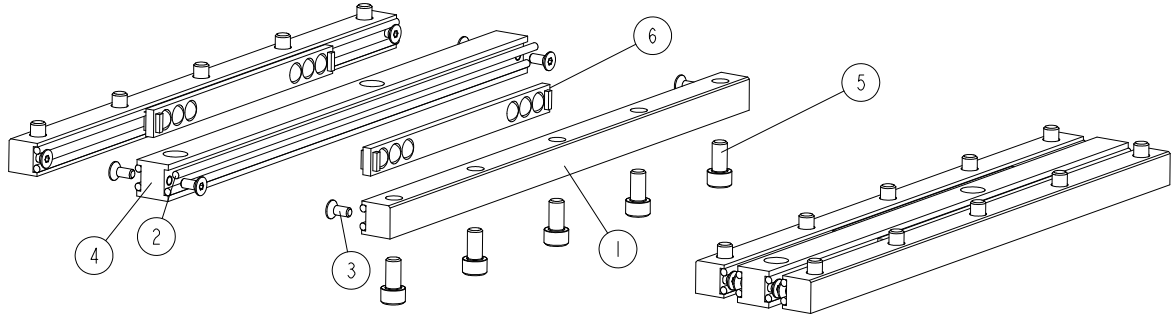

REF	DESCRIPTION (◆ indicates parts available in assemblies only)	PART #	QTY
-	<b>GUIDES TABLE</b>	546487	1
1	RAIL GUIDE 1	541423-1	4
2	ROD GUIDE	541424	16
3	SCREW, M5X12-10.9 DIN7991(BN 0021) FLAT	F81000-45	16
4	RAIL GUIDE 2	541425-1	2
5	SCREW, M8X16-8.8 HEX SOCKET HEAD CAP ZIN	F81002-39	20
6	RAIL GUIDE	546486	4