

Wood-Mizer®

Parts List

AL-KO O1 Trailer for LT15SA (Standard) rev. A1.02
AL-KO O2 Trailer for LT15SC (Classic) rev. A1.02
AL-KO Trailer for LT15WC (Wide) rev. A1.00



Safety is our #1 concern! Read and understand all safety information and instructions before operating, setting up or maintaining this machine.

Form #2489

Table of Contents

Section-Page

SECTION 1	PARTS LIST	1-1
1.1	How to Use the Parts List.....	1-1
1.2	Sample Assembly	1-1
1.3	Complete Axle, LT15 O1 Trailer	1-2
1.4	Drawbar w/o Homologation, LT15 O1	1-4
1.5	Drawbar w/ Homologation, LT15 O1	1-6
1.6	Steady Legs, LT15 O1 (Frame 1950)	1-8
1.7	Rear Light Beam, LT15 O1	1-9
1.8	Blade Height Scale, LT15 Mobile O1	1-11
1.9	Equipment Kit, LT15 O1	1-13
1.10	Equipment Kit, LT15SAS3 Mobile.....	1-15
1.11	Log Ramp w/Winch for LT15 Sawmills w/0.75 Trailer	1-16
1.12	Individual Homologation Kit, LT15SA (optional).....	1-17
1.13	Axle Assembly, LT15 O2	1-18
1.14	Leg Set, LT15 Mobile O2	1-21
1.15	Rear Light Beam, LT15 O2	1-22
1.16	Rear Light Beam, LT15 O2 - Service Kit	1-24
1.17	Drawbar w/Overrun Device, LT15 O2	1-25
1.18	Drawbar w/Overrun Device, LT15 O2 WFL	1-26
1.19	Blade Height Scale, LT15 O2	1-28
1.20	Additional Equipment (LT15 O2)	1-30
1.21	Individual Homologation Kit, LT15SC (optional).....	1-31
1.22	LT15 Manual Log Turner (Optional)	1-32
1.23	Saw Head Safety Belt	1-34
1.24	Axle Assembly, Trailer for LT15 Wide	1-35
1.25	Axle Assembly, Trailer for LT15 Wide - WFL version.....	1-37
1.26	Fender with Mount Bracket - Right, Trailer for LT15 Wide	1-38
1.27	Fender with Mount Bracket - Left, Trailer for LT15 Wide.....	1-40
1.28	Fender with Mount Bracket, Trailer for LT15 Wide, WFL version	1-42
1.29	Leg Set, Trailer for LT15 Wide.....	1-44
1.30	Rear Light Beam, Trailer for LT15 Wide	1-45
1.31	Drawbar with Overrun Device, Trailer for LT15 Wide	1-47
1.32	Additional Equipment, Trailer for LT15 Wide	1-49
1.33	Log Ramp w/Winch, LT15 Wide.....	1-50
1.34	Blade Height Scale, LT15 Wide (mobile sawmills).....	1-52

SECTION 1 PARTS LIST

1.1 How to Use the Parts List

- Use the index above to locate the assembly that contains the part you need.
- Go to the appropriate section and locate the part in the illustration.
- Use the number pointing to the part to locate the correct part number and description in the table.
- Parts shown indented under another part are included with that part.
- Parts marked with a diamond (◆) are only available in the assembly listed above the part.

See the sample table below. Sample Part #A01111 includes part F02222-2 and subassembly A03333. Subassembly A03333 includes part S04444-4 and subassembly K05555. The diamond (◆) indicates that S04444-4 is not available except in subassembly A03333. Subassembly K05555 includes parts M06666 and F07777-77. The diamond (◆) indicates M06666 is not available except in subassembly K05555.

1.2 Sample Assembly				
REF.	DESCRIPTION (◆ Indicates Parts Available In Assemblies Only)	PART #	QTY	
	Sample Assembly, Complete (Includes All Indented Parts Below)	A01111	1	
1	Sample Part	F02222-2	1	
	Sample Subassembly (Includes All Indented Parts Below)	A03333	1	
2	Sample Part (◆ Indicates Part Is Only Available With A03333)	S04444-4	1	◆
	Sample Subassembly (Includes All Indented Parts Below)	K05555	1	
3	Sample Part (◆ Indicates Part Is Only Available With K05555)	M06666	2	◆
4	Sample Part	F07777-77	1	

To Order Parts:

- From Europe call our European Headquarters and Manufacturing Facility in Kolo, Poland at **+48-63-2626000**. From the continental U.S., call our toll-free Parts hotline at **1-800-525-8100**. Have your customer number, vehicle identification number, and part numbers ready when you call. From other international locations, contact the Wood-Mizer distributor in your area for parts.

Office Hours:

Country	Monday - Friday	Saturday	Sunday
Poland	7-15	Closed	Closed
US	8 a.m.- 5 p.m.	8 a.m.- 12 p.m.	Closed



CAUTION! It is strongly recommended that only original spare parts be used.

1.3 Complete Axle, LT15 O1 Trailer

538506_004_A
538506_MANUAL

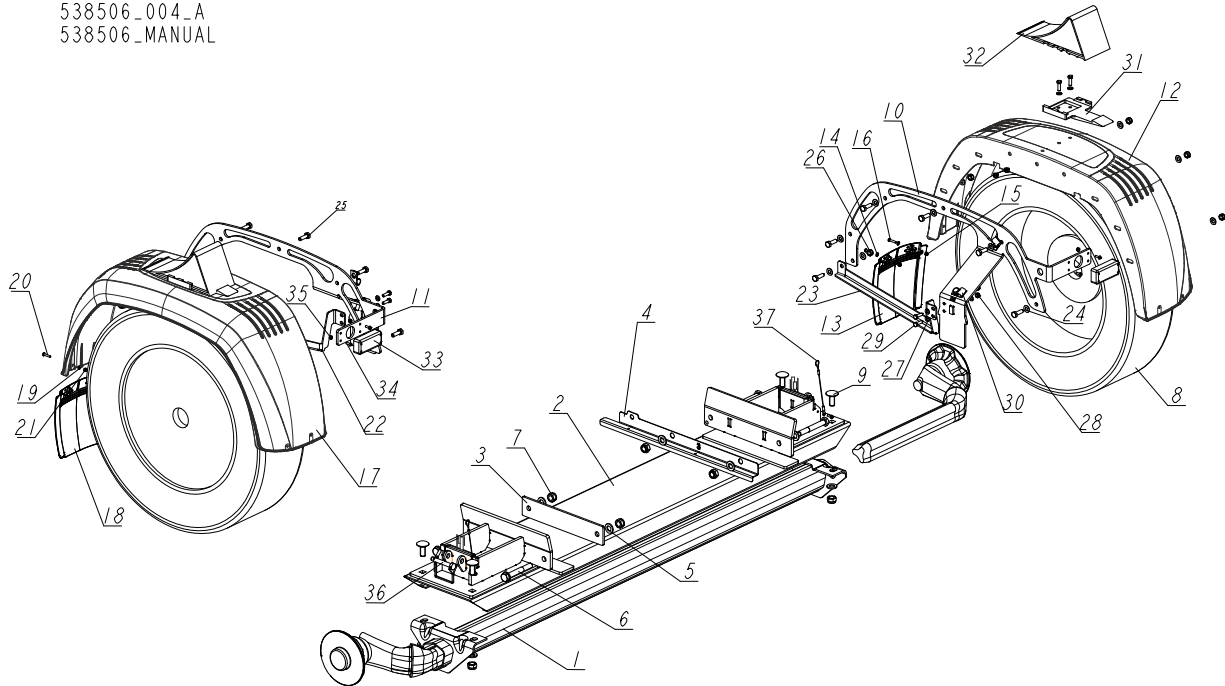

REF.	DESCRIPTION (* indicates parts available in assemblies only)	PART #	QTY
-	AXLE, LT15 O1 TRAILER COMPLETE	538506	1
1	AXLE, 750KG A=1300 C=1730 (200 596 12) U	538549	1
2	MOUNT ASSEMBLY, AXLE	538501-1	1
3	PLATE, FENDER BRACKET	501165-1	1
4	PLATE	538789-1	1
5	WASHER, M12, FLAT, ZINC	F81056-1	12
6	BIOLT, M12X90 8.8 HEX HEAD ZINC	F81004-2	4
7	NUT, M12-8, HEX,NYLON,ZINC,LOCK	F81034-2	8
8	WHEEL, 155/80 R13 4X100 ET30 COMPLETE	501134	2
9	BOLT, M12X30 8.8 FE/ZN5 DIN 603, CARRIAG	F81004-61	4
10	MOUNT WELDMENT, FENDER - RIGHT	538912-1	1
11	MOUNT WELDMENT, FENDER - LEFT	538910-1	1
-	FENDER, 200MM P (1 259 580) W/MUD FLAP	538906	1
12	FENDER, AL-KO EA200 (1 259 576)	538909	1
13	MUD FLAP, 200MM (1 258 651)	538824	1
14	WASHER 4,3 ZC DIN 126 ISO 7091	F81051-2	4
15	NUT M4 ZC 8 NYLOCK DIN 982 ISO 7040	F81029-1	2
16	SCREW, ISO 7045-M4X20-4.8-H-A2 CROSS REC	F81011-46	2

1

PARTS LIST

Complete Axle, LT15 O1 Trailer

REF.	DESCRIPTION (* indicates parts available in assemblies only)	PART #	QTY	
-	FENDER, 200MM (1 259 347) W/MUD FLAP - L	538907	1	
17	FENDER, AL-KO EA200 (1 259 576)	538909	1	
18	MUD FLAP, 200MM (1 258 651)	538824	1	
19	WASHER 4,3 ZC DIN 126 ISO 7091	F81051-2	4	
20	SCREW, ISO 7045-M4X20-4.8-H-A2 CROSS REC	F81011-46	2	
21	NUT M4 ZC 8 NYLOCK DIN 982 ISO 7040	F81029-1	2	
22	PLATE	538891-1	1	
23	PLATE	538892-1	1	
24	WASHER, 8.4 FLAT,ZINC	F81054-1	27	
25	BOLT,M8X25-8.8-B HEX HEAD FULL THREAD ZI	F81002-5	14	
26	NUT, M8-8-B HEX NYLON ZINC LOCK	F81032-2	14	
27	WASHER, M6, FLAT,ZINC	F81053-1	16	
28	NUT, M6-8-B HEX NYLON ZINC LOCK	F81031-2	8	
29	BOLT, M6X20-8.8 HEX HEAD FULL THREAD ZIN	F81001-2	8	
30	CLAMP, 1/2" EMT COATED	P07584	4	
31	HANDLE, TRAILER WEDGE STOP	P85106	2	
32	WEDGE, TIRE, TRAILER STOP	P85105	2	
33	LIGHTS, CONTOUR WHITE, HORIZONTAL HOLES	E85131	2	
34	SCREW M4X12 PHILLIPS ZC 5.8 DIN 7985	F81011-43	6	
35	NUT M4 ZC 8 NYLOCK DIN 982 ISO 7040	F81029-1	4	
36	PIN, 3/8 X 2 1/4 SQ WIRE LOCK	014151	2	
37	LANYARD, 3/64 X 6	016030	2	
-	WHEEL BOLT TAPER, M12X1.5 LT15SA	550507	8	

1.4 Drawbar w/o Homologation, LT15 O1

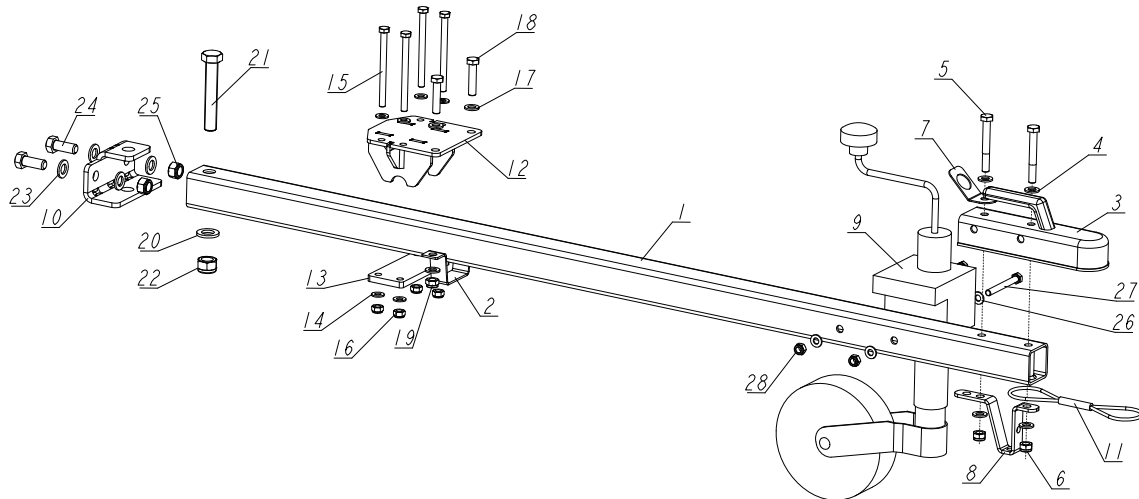
538884_001
538884_MANUAL

REF.	DESCRIPTION (* indicates parts available in assemblies only)	PART #	QTY
-	DRAWBAR, LT1501 W/O HOMOLOGATION	538884	1
1	TUBE WELDMENT, DRAWBAR	538885-1	1
2	SKID, AL-KO (589 087) CLAMPING	538522	1
3	HEAD, AK7 KW60 (1 224 743) COUPLING	538520	1
4	WASHER, 13 FLAT ZINC	F81056-1	4
5	BOLT, M12X90 8.8 HEX HEAD ZINC	F81004-2	2
6	NUT, M12-8 DIN 982 HEX NYLON ZINC LOCK	F81034-2	2
7	HOLDER, AL-KO (218 260 00 04) PLUG	538889	1
8	BRACKET, AL-KO (203 037) SKID	538890	1
9	WHEEL, N48 JOCKEY W/CLAMP (1 222 434+205 318)	538523	1
10	PLATE, DRAWBAR MOUNT	538816-1	1
11	CABLE, AL-KO (1 236 099) SAFETY	538825	1
-	BRACKET, O1 DRAWBAR MOUNT - COMPLETE	538864	1
12	BRACKET, O1 DRAWBAR MOUNT	538862-1	1
13	PLATE, BRACKET CLAMPING	538898-1	1
14	WASHER, 10.5 FLAT ZINC	F81055-1	8
15	BOLT, ISO4014 M10X130-8.8-A2E HEX HEAD	F81003-132	4
16	NUT, M10-8-B HEX NYLON ZINC LOCK	F81033-1	4
17	WASHER, 13 FLAT ZINC	F81056-1	4
18	BOLT, M12X45-8.8 HEX HEAD FULL THREAD ZINC	F81004-76	2
19	NUT, M12-8 DIN 982 HEX NYLON ZINC LOCK	F81034-2	2
20	WASHER, 21 FLAT ZINC	F81059-2	1
21	BOLT, M20X120-8.8 HEX HEAD FULL THREAD (BLACK)	F81007-18	1
22	NUT, M20-8 DIN985 HEX NYLON ZINC LOCK	F81037-2	1
23	WASHER, 17 SPLIT LOCK ZINC	F81058-1	4

1**PARTS LIST***Drawbar w/o Homologation, LT15 O1*

REF.	DESCRIPTION (* indicates parts available in assemblies only)	PART #	QTY	
24	BOLT, M16X40-8.8 HEX HEAD FULL THREAD ZINC	F81006-13	2	
25	NUT, M16-8 HEX NYLON ZINC LOCK	F81036-2	2	
26	WASHER, 10.5 FLAT ZINC	F81055-1	4	
27	BOLT, M10X85-8.8-B HEX HEAD ZINC	F81003-125	2	
28	NUT, M10-8-B HEX NYLON ZINC LOCK	F81033-1	2	

1.5 Drawbar w/ Homologation, LT15 O1

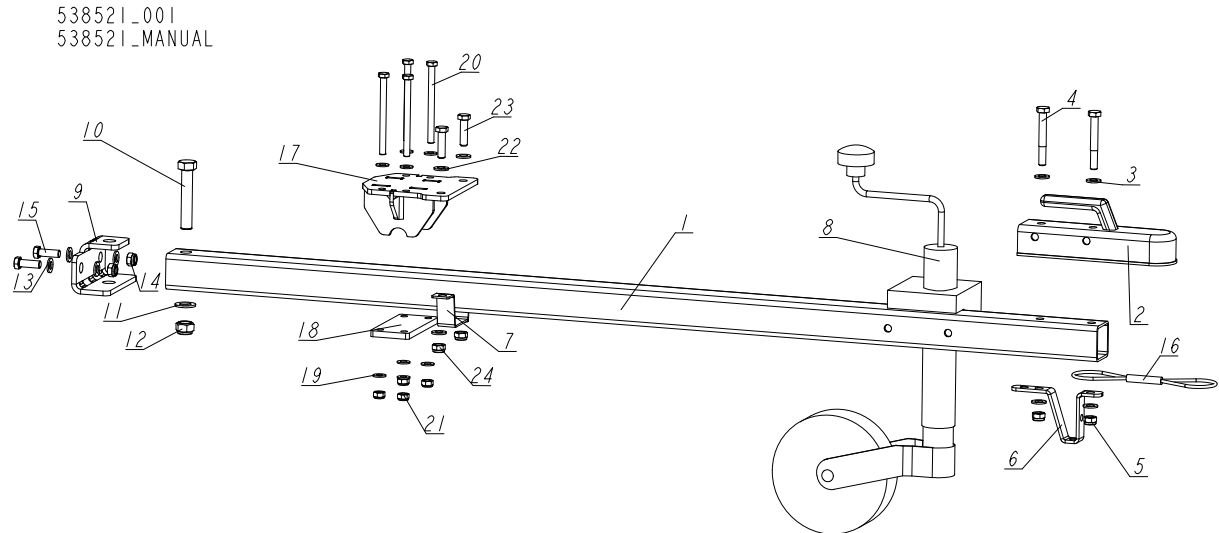

REF.	DESCRIPTION (* indicates parts available in assemblies only)	PART #	QTY
-	DRAWBAR, LT1501 W/ HOMOLOGATION	538521	1
-	DRAWBAR, R4 L1715 (200 350 02)	538780	1
1	TUBE WELDMENT, DRAWBAR	538764-1	1
2	HEAD, AK7 KW60 (1 224 743) COUPLING	538520	1
3	WASHER, 13 FLAT ZINC	F81056-1	4
4	BOLT, M12X90 8.8 HEX HEAD ZINC	F81004-2	2
5	NUT, M12-8 HEX NYLON ZINC LOCK	F81034-2	2
6	BRACKET, AL-KO (203 037) SKID	538890	1
7	SKID, AL-KO (589 087) CLAMPING	538522	1
8	WHEEL, N48 JOCKEY W/CLAMP (1 222 434+205)	538523	1
9	PLATE, DRAWBAR MOUNT	538816-1	1
10	BOLT, M18X100 -8.8 HEX HEAD ZINC	F81008-4	1
11	WASHER, 19 FLAT ZINC	F81060-1	1
12	NUT, M18 HEX NYLON LOCK	F81039-15	1
13	WASHER, 13 FLAT ZINC	F81056-1	4
14	NUT, M12-8 HEX NYLON ZINC LOCK	F81034-2	2
15	BOLT, M12 X 35-8.8 HEX HEAD FULL THREAD	F81004-24	2
16	CABLE, AL-KO (1 236 099) SAFETY	538825	1
-	BRACKET, O1 DRAWBAR MOUNT - COMPLETE	538864	1
17	BRACKET, O1 DRAWBAR MOUNT	538862-1	1
18	PLATE, BRACKET CLAMPING	538898-1	1
19	WASHER, 10.5 FLAT ZINC	F81055-1	8
20	BOLT, ISO4014 M10X130-8.8-A2E HEX HEAD	F81003-132	4
21	NUT, M10-8-B HEX NYLON ZINC LOCK	F81033-1	4
22	WASHER, 13 FLAT ZINC	F81056-1	4

1**PARTS LIST***Drawbar w/ Homologation, LT15 O1*

REF.	DESCRIPTION (* indicates parts available in assemblies only)	PART #	QTY	
23	BOLT, M12X45-8.8 HEX HEAD FULL THREAD ZI	F81004-76	2	
24	NUT, M12-8 HEX NYLON ZINC LOCK	F81034-2	2	

1.6 Steady Legs, LT15 O1 (Frame 1950)

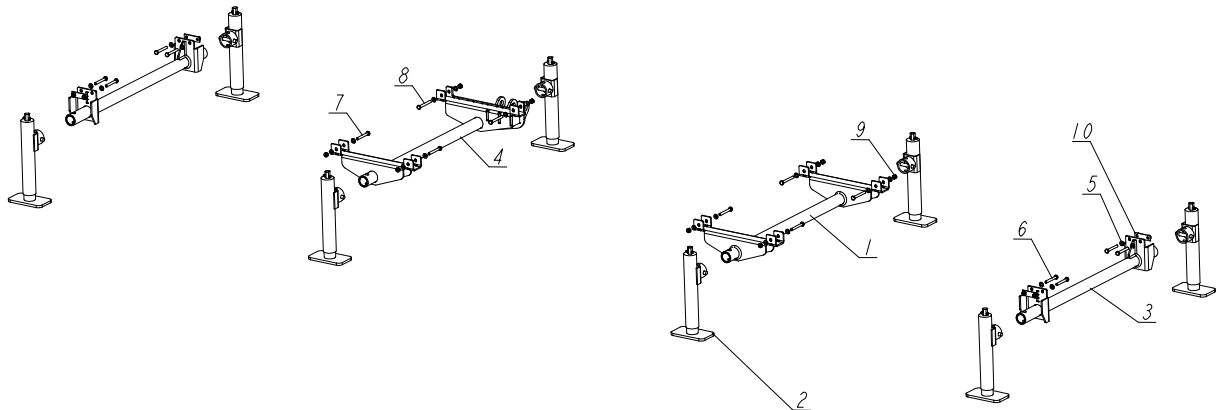
538525_001_A
538525_MANUAL

REF.	DESCRIPTION (* indicates parts available in assemblies only)	PART #	QTY
-	LEG SET, LT15 O1 STEADY (FRAME 1950)	538525	1
1	MOUNT WELDMENT, 01 TRAILER LEG	538753-1	1
2	LEG, SUPPORT - COMPLETE	550455	8
	CRANK, 140X665X12 SW19 HAND COMPLETE	084536	1
3	MOUNT WELDMENT, REAR LEG	538756-1	2
4	MOUNT WELDMENT, 01 TRAILER LEG	538820-1	1
5	WASHER, 10.5 FLAT ZINC	F81055-1	24
6	BOLT, M10X75-8.8 HEX HEAD ZINC	F81003-15	8
7	BOLT, M10X80-8.8 HEX HEAD ZINC	F81003-50	4
8	BOLT, M10X85-8.8 HEX HEAD ZINC	F81003-125	4
9	NUT, M10-8-B HEX NYLON ZINC LOCK	F81033-1	16
10	WASHER, LT15 BED LEG	085994-1	4

1

PARTS LIST

Rear Light Beam, LT15 O1

1.7 Rear Light Beam, LT15 O1

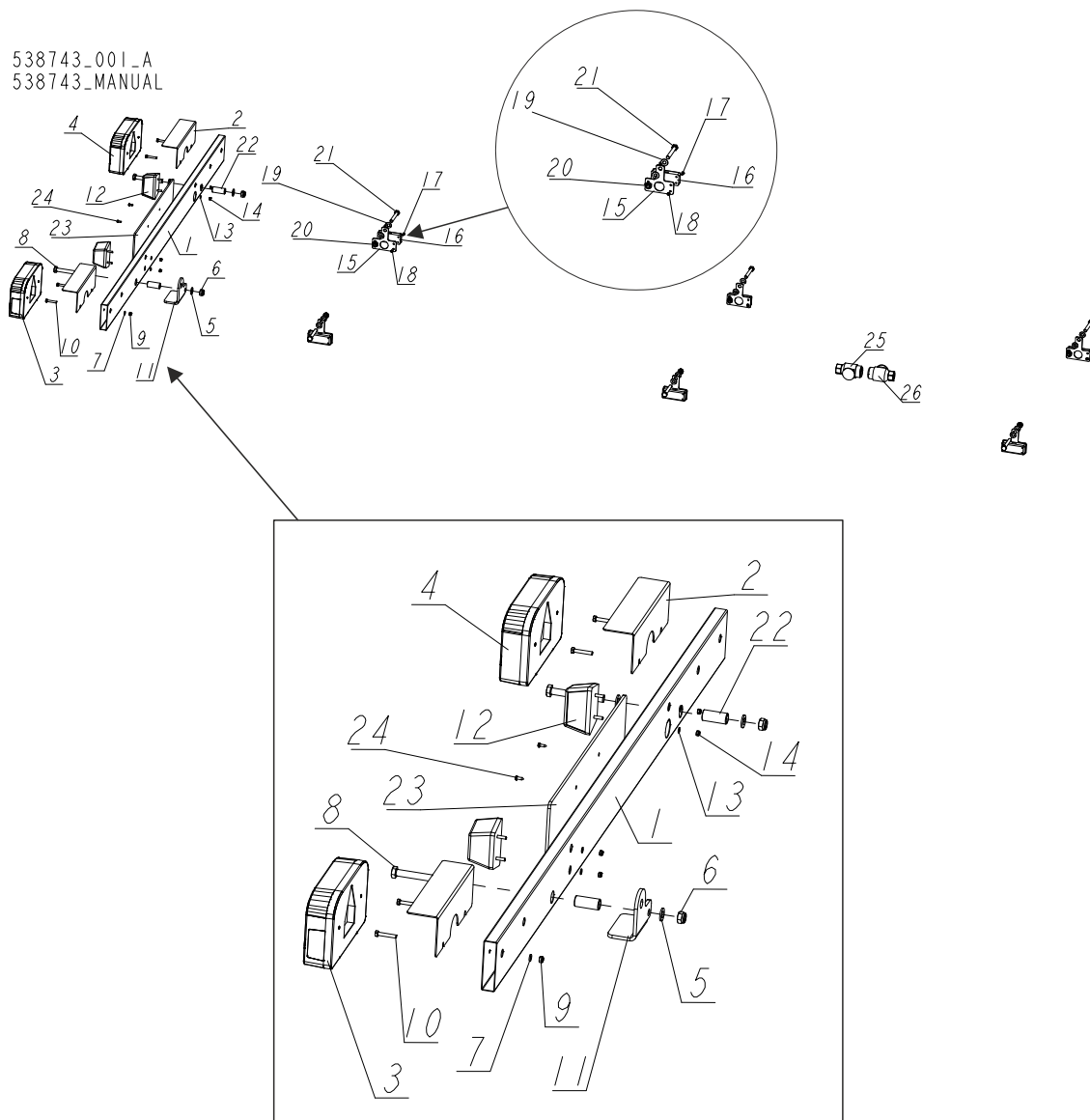

REF.	DESCRIPTION (* indicates parts available in assemblies only)	PART #	QTY
-	BEAM, LT15 O1 REAR - COMPLETE	538743	1
1	BEAM, ALUMINUM LIGHT	538858	1
2	GUARD, LIGHT	538880-1	2
3	LIGHT, FT-089 LEFT REAR	538718	1
4	LIGHT, FT-089 RIGHT REAR	538716	1
5	WASHER, 13 FLAT ZINC	F81056-1	4
6	NUT, M12-8 HEX NYLON ZINC LOCK	F81034-2	2
7	WASHER, 6.4 FLAT ZINC	F81053-1	4
8	BOLT, M12 X 100MM,HH,GRADE 5.8,ZINC	F81004-3	2
9	NUT, M6-8-B HEX NYLON ZINC LOCK	F81031-2	4

PARTS LIST
Rear Light Beam, LT15 O1

1

REF.	DESCRIPTION (* indicates parts available in assemblies only)	PART #	QTY	
10	BOLT M6X35 8.8	F81001-71	4	
11	PLATE	538777-1	1	
12	LIGHT, LT120 LICENCE PLATE	088597	2	
13	WASHER, 5.3 FLAT ZINC	F81052-1	4	
14	NUT, M5-8-FE/ZN5 DIN985	F81030-2	4	
-	LIGHT, MARKER - COMPLETE	538739	6	
15	PLATE, FL-011 LIGHT MOUNT	538738-1	1	
16	LIGHTS, CONTOUR YELLOW, CROSSWISE HOLES	E85217	1	
17	SCREW, M4X12 5,8-B CROSS RECESSED PAN HE	F81011-43	2	
18	NUT M4-B FE/ZN5 PN-M/82175	F81029-1	2	
19	WASHER, 10.5 FLAT ZINC	F81055-1	12	
20	NUT, M10-8-B HEX NYLON ZINC LOCK	F81033-1	6	
21	BOLT, M10X75-8.8-FE/ZN5 PN-M/82101	F81003-15	6	
22	BUSHING, 14/20-46	538901-1	2	
23	FRAME, LICENCE PLATE	550585	1	
24	SCREW, 4.2 X 13	F81010-1	2	

1 PARTS LIST

Blade Height Scale, LT15 Mobile O1

1.8 Blade Height Scale, LT15 Mobile O1

538837_001
538837_MANUAL

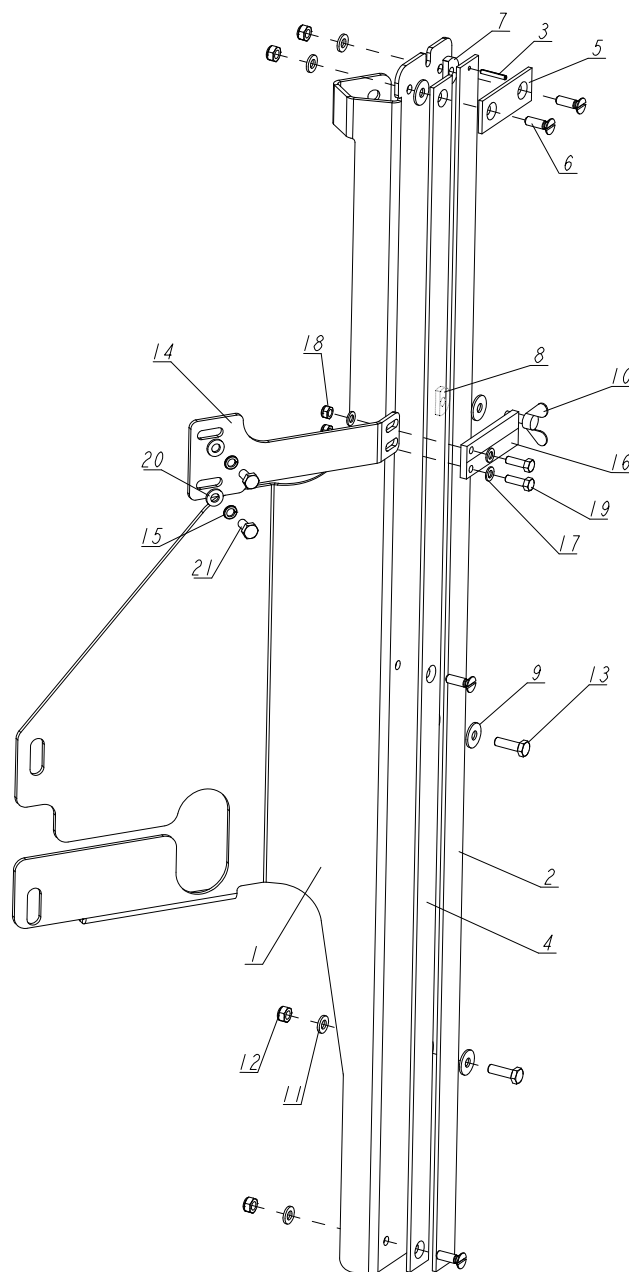

REF.	DESCRIPTION (* indicates parts available in assemblies only)	PART #	QTY
-	SCALE ASSEMBLY, LT15 MOBILE O1 BLADE HEIGHT	538837	1
-	BASE, BLADE HEIGHT SCALE - COMPLETE	538648	1
1	BRACKET WELDMENT, BLADE HEIGHT SCALE	538848-1	1
2	BAR, INCH SCALE	093133	1
3	PIN, 3X20 GEOMET ROLL	F81044-5	1
4	BAR, SCALE	092750	1
5	BAR, SCALE CLAMP	093134	1

PARTS LIST*Blade Height Scale, LT15 Mobile O1***1**

REF.	DESCRIPTION (* indicates parts available in assemblies only)	PART #	QTY	
6	SCREW, M6X20-5.8-B SLOTTED COUNTERSUNK HEAD ZINC	F81001-31	4	
7	WASHER, 6.2X20X4.5 SPECIAL	503098	3	
8	WASHER, 6.2X20X3.5 SPECIAL	503096	1	
9	WASHER, 6.5 SPECIAL FLAT ZINC	F81053-11	4	
10	SCREW, M6X16 DIN-316/BN-276 ZINC-PL. WING	F81001-16	1	
11	WASHER, 6.4 FLAT ZINC	F81053-1	6	
12	NUT, M6-8-B HEX NYLON ZINC LOCK	F81031-2	6	
13	BOLT, M6X20 8.8 HEX HEAD FULL THREAD ZINC	F81001-2	2	
14	PLATE, SCALE INDICATOR MOUNT	538711-1	1	
15	WASHER, Z 6.1 SPLIT LOCK ZINC	F81053-3	2	
16	INDICATOR, BLADE HEIGHT SCALE	094821	1	
17	WASHER, 5.3 FLAT ZINC	F81052-1	4	
18	NUT, M5-8 DIN985 HEX NYLON ZINC LOCK	F81030-2	2	
19	BOLT, M5 X 16-8.8 HEX HEAD FULL THREAD ZINC	F81000-20	2	
20	WASHER, 6.4 FLAT ZINC	F81053-1	2	
21	BOLT, M6X12 8.8 HEX HEAD FULL THREAD ZINC	F81001-7	2	



PARTS LIST

Equipment Kit, LT15 O1

1.9 Equipment Kit, LT15 O1

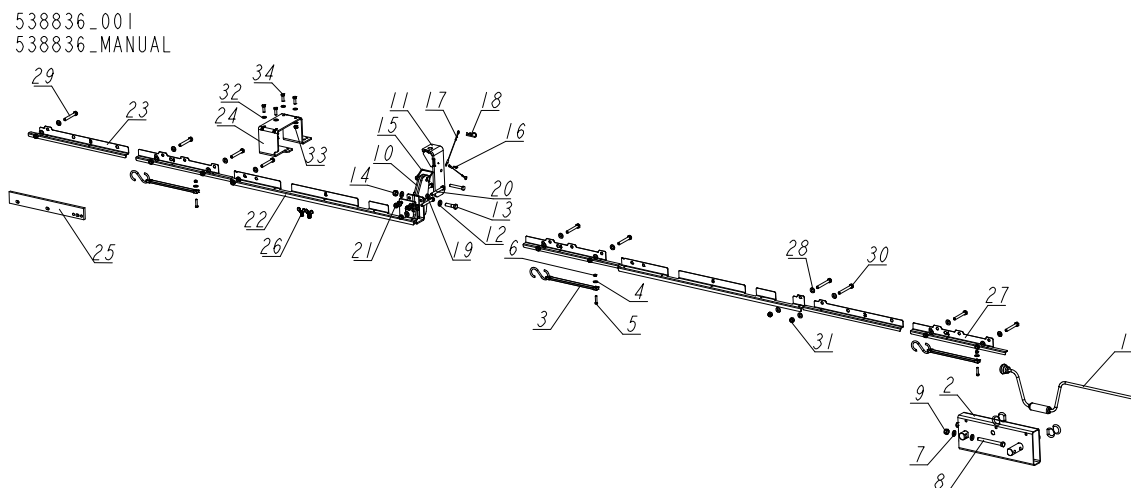

REF.	DESCRIPTION (* indicates parts available in assemblies only)	PART #	QTY
-	EQUIPMENT KIT, LT15 MOBILE O1	538836	1
1	HANDLE, HKB SW 19-L660 (W 4460) CRANK - COMPLETE	084536	1
2	EXTENSION, MAST TRACK	538759-1	1
-	STRAP, CLAMP TRANSPORT LOCK	538835	1
3	STRAP, 9" RUBBER WITH HOOKS	012965	3
4	WASHER, 6.5 SPECIAL FLAT ZINC	F81053-11	3
5	BOLT, M6X30-8.8 HEX HEAD FULL THREAD ZINC	F81001-8	3
6	NUT, M6-8-B HEX NYLON ZINC LOCK	F81031-2	3
7	WASHER, 13 FLAT ZINC	F81056-1	4
8	BOLT, M12X120-8.8 HEX HEAD ZINC	F81004-38	2
9	NUT, M12-8 DIN 982 HEX NYLON ZINC LOCK	F81034-2	2
-	SUPPORT, SAW HEAD	538806	1
10	BRACKET, SAW HEAD SUPPORT MOUNT	538804-1	1
-	BRACKET, SAW HEAD SUPPORT - COMPLETE	538706	1
11	BRACKET, SAW HEAD SUPPORT	538813-1	1
12	WASHER, 13 FLAT ZINC	F81056-1	2
13	BOLT, M12X45 8.8 HEX HEAD ZINC	F81004-32	1
14	NUT, M12-8 DIN 982 HEX NYLON ZINC LOCK	F81034-2	1
15	PIN, 3/8 X 2 1/4 SQ WIRE LOCK	014151	1
16	SCREW, M4X12 -5.8-B CROSS RECESSED PAN HEAD ZINC	F81011-43	1
17	LANYARD, 3/64 X 6	016030	2
18	PIN, 1/8X1 13/16 SAFETY	P05059	1
19	WASHER, 10.5 FLAT ZINC	F81055-1	4
20	BOLT, M10X80-8.8 HEX HEAD ZINC	F81003-50	2
21	NUT, M10-8-B HEX NYLON ZINC LOCK	F81033-1	2
22	PLATE	538792-1	2
23	PLATE	538789-1	2

PARTS LIST
Equipment Kit, LT15 O1

1

REF.	DESCRIPTION (* indicates parts available in assemblies only)	PART #	QTY	
24	PLATE	538770-1	1	
25	RAIL, EXTENSION ZINC-PLATED TRACK	538823-1	1	
26	SCREW, M8-1.25X16 WING	F05021-32	2	
27	PLATE	538838-1	3	
28	WASHER, 10.5 FLAT ZINC	F81055-1	22	
29	BOLT, M10X75-8.8 HEX HEAD ZINC	F81003-15	9	
30	BOLT, M10X85-8.8 HEX HEAD ZINC	F81003-125	2	
31	NUT, M10-8-B HEX NYLON ZINC LOCK	F81033-1	11	
32	WASHER, 8.4 FLAT ZINC	F81054-1	8	
33	NUT, M8-8-B HEX NYLON ZINC LOCK	F81032-2	4	
34	BOLT, M8X25-8.8-B HEX HEAD FULL THREAD ZINC	F81002-5	4	

1

PARTS LIST

Equipment Kit, LT15SAS3 Mobile

1.10 Equipment Kit, LT15SAS3 Mobile

538853_001
538853_MANUAL

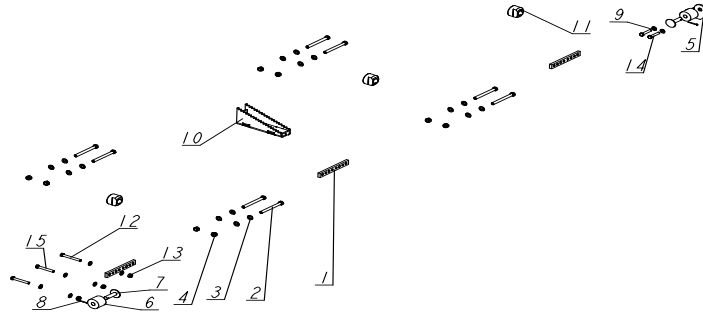

REF.	DESCRIPTION (* indicates parts available in assemblies only)	PART #	QTY
-	EQUIPMENT KIT, LT15SAS3 MOBILE	538853	1
1	SPLICE, TRACK RAIL PINNED ZINC-PLATED	086659-1	3
2	BOLT, M12X120-8.8 HEX HEAD ZINC	F81004-38	8
3	WASHER, 13 FLAT ZINC	F81056-1	16
4	NUT, M12-8 DIN 982 HEX NYLON ZINC LOCK	F81034-2	8
5	PLATE, LT15 POWER FEED SUPPORT	501414-1	1
6	BUSHING, 11/16X2 1/8X1 3/4 RUBBER	P12165	2
7	MOUNT WELDMENT, SAW HEAD STOP	086182-1	2
8	PIN, S-ZN 4X25 COTTER	F81043-2	2
9	WASHER, 10.5 FLAT ZINC	F81055-1	10
10	WEDGE, LT15 LOG TAPER ZINC-PLATED	510720-1	1
11	CAP, CLAMPING	T00414	3
12	BOLT, M10X85-8.8 HEX HEAD ZINC	F81003-125	1
13	NUT, M10-8-B HEX NYLON ZINC LOCK	F81033-1	5
14	BOLT, M10X50-8.8 HEX HEAD FULL THREAD ZINC	F81003-4	2
15	BOLT, M10X75-8.8 HEX HEAD ZINC	F81003-15	2

1.11 Log Ramp w/Winch for LT15 Sawmills w/0.75 Trailer

538822_001
538822_MANUAL

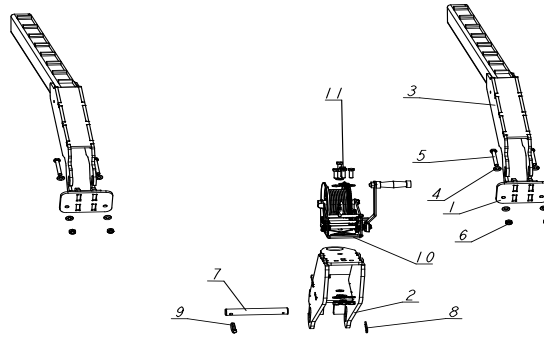

REF.	DESCRIPTION (* indicates parts available in assemblies only)	PART #	QTY
-	LOG RAMP W/WINCH, LT15 0.75 TRAILER	538822	1
1	BRACKET, RAMP MOUNT	534674-1	2
2	MOUNT WELDMENT, WINCH	534653-1	1
3	LOG RAMP - COMPLETE	543500-1	2
4	WASHER, 10.5 FLAT ZINC	F81055-1	18
5	BOLT, M10X85-8.8 HEX HEAD ZINC	F81003-125	4
6	NUT, M10-8-B HEX NYLON ZINC LOCK	F81033-1	9
7	PIN, LOCK	534657-1	1
8	PIN, 1/8X1 13/16 SAFETY	P05059	1
9	PIN, 8 BN914 LINCH (BOSSARD 1364650)	F81046-2	1
10	WINCH, DWK 35V HAND	534651	1
11	SCREW, DIN933-M10X30-8.8-A2E HEX CAP FULL THREAD	F81003-111	5

1 PARTS LIST

Individual Homologation Kit, LT15SA (optional)

1.12 Individual Homologation Kit, LT15SA (optional)

550477_001
550477_MANUAL

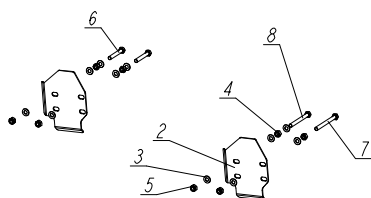

REF.	DESCRIPTION (* indicates parts available in assemblies only)	PART #	QTY	
-	INDIVIDUAL HOMOLOGATION KIT, LT15SA	550477	1	
1	CAP, 100X25X1.5-3 498692	550476	2	
2	CAP, TUBE END	550457-1	2	
3	WASHER, 10.5 FLAT ZINC	F81055-1	11	
4	NUT, M10 8 HEX ZINC	F81033-3	4	
5	NUT, M10-8-B HEX NYLON ZINC LOCK	F81033-1	4	
6	BOLT, M10X70 8.8 HEX HEAD FULL THREAD ZINC	F81003-20	2	
7	BOLT, M10X110 8.8 HEX HEAD ZINC	F81003-43	1	
8	BOLT, M10X100-8.8 FE/ZN5 PN-M/82101	F81003-52	1	

1.13 Axle Assembly, LT15 O2

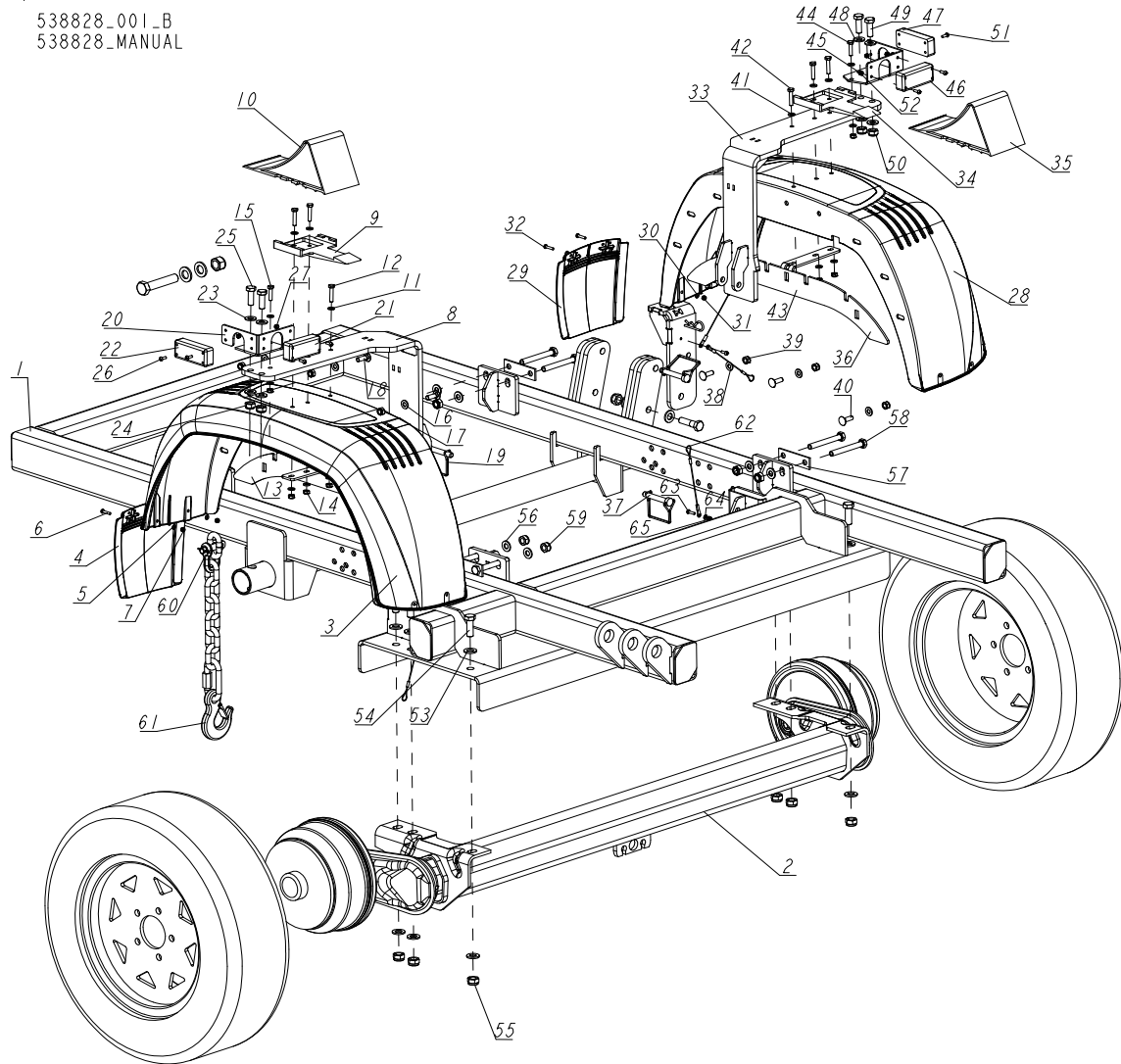

REF.	DESCRIPTION (* indicates parts available in assemblies only)	PART #	QTY
-	AXLE, LT15 O2 - COMPLETE	538828	1
-	AXLE, LT15 O2 WFL - COMPLETE	538868	1
1	FRAME, LT15GO AXLE MOUNT	534600-1	1
2	AXLE, DMC 1500 A=1000 C=1450 (#247 556)	538644	1
-	FENDER W/MOUNT BRACKET	534664	1
-	FENDER, 200MM (1 259 347) W/MUD FLAP - L	538907	1
3	FENDER, AL-KO EA200 (1 259 576)	538909	1
4	MUD FLAP, 200MM (1 258 651)	538824	1
5	WASHER, 4.3 FLAT ZINC	F81051-2	4
6	SCREW, ISO 7045-M4X20-4.8-H-A2 CROSS REC	F81011-46	2
7	NUT, M4-8 HEX NYLON ZINC LOCK	F81029-1	2
8	BRACKET WELDMENT, FENDER MOUNT	534666-1	1

1

PARTS LIST*Axle Assembly, LT15 O2*

REF.	DESCRIPTION (* indicates parts available in assemblies only)	PART #	QTY	
9	HANDLE, TRAILER WEDGE STOP	P85106	1	
10	WEDGE, TIRE, TRAILER STOP	P85105	1	
11	WASHER, 6.4 FLAT ZINC	F81053-1	8	
12	BOLT, M6X30-8.8 HEX HEAD FULL THREAD ZIN	F81001-8	3	
13	BRACE, FENDER	550614-1	1	
14	NUT, M6-8-B HEX NYLON ZINC LOCK	F81031-2	4	
15	BOLT, M6X25-5.8 HEX HEAD FULL THREAD ZIN	F81001-3	1	
16	WASHER, 8.4 FLAT ZINC	F81054-1	3	
17	NUT, M8-8-B HEX NYLON ZINC LOCK	F81032-2	3	
18	BOLT, M8X25 8.8 CARRIAGE ZINC	F81002-59	3	
19	PIN, 3/8X2 1/4 SNAP	014151	1	
20	PLATE, MARKER & FRONT LEFT LIGHT MOUNT	538865-1	1	
21	LIGHTS, CONTOUR WHITE, HORIZONTAL HOLES	E85131 ¹	1	
22	LIGHTS, CONTOUR YELLOW, CROSSWISE HOLES	E85217 ²	1	
23	WASHER, 10.5 FLAT ZINC	F81055-1	4	
24	NUT, M10-8-B HEX NYLON ZINC LOCK	F81033-1	2	
25	BOLT, DIN933-M10X30-8.8-A2E HEX HEAD	F81003-111	2	
26	SCREW, M4X12 5,8-B CROSS RECESSED PAN HE	F81011-43	4	
27	NUT, M4-8 HEX NYLON ZINC LOCK	F81029-1	4	
-	FENDER W/MOUNT BRACKET	538831	1	
-	FENDER, 200MM P (1 259 580) W/MUD FLAP	538906	1	
28	FENDER, AL-KO EA200 (1 259 576)	538909	1	
29	MUD FLAP, 200MM (1 258 651)	538824	1	
30	WASHER, 4.3 FLAT ZINC	F81051-2	4	
31	NUT, M4-8 HEX NYLON ZINC LOCK	F81029-1	2	
32	SCREW, ISO 7045-M4X20-4.8-H-A2 CROSS REC	F81011-46	2	
33	BRACKET WELDMENT, FENDER MOUNT	538900-1	1	
34	HANDLE, TRAILER WEDGE STOP	P85106	1	
35	WEDGE, TIRE, TRAILER STOP	P85105	1	
36	BRACE, FENDER	550614-1	1	
37	PIN, 3/8X2 1/4 SNAP	014151	1	
38	WASHER, 8.4 FLAT ZINC	F81054-1	3	
39	NUT, M8-8-B HEX NYLON ZINC LOCK	F81032-2	3	
40	BOLT, M8X25 8.8 CARRIAGE ZINC	F81002-59	3	
41	WASHER, 6.4 FLAT ZINC	F81053-1	8	
42	BOLT, M6X30-8.8 HEX HEAD FULL THREAD ZIN	F81001-8	3	
43	NUT, M6-8-B HEX NYLON ZINC LOCK	F81031-2	4	
44	BOLT, M6X25-5.8 HEX HEAD FULL THREAD ZIN	F81001-3	1	
45	PLATE, MARKER & FRONT RIGHT LIGHT MOUNT	538866-1	1	
46	LIGHTS, CONTOUR WHITE, HORIZONTAL HOLES	E85131 ³	1	
47	LIGHTS, CONTOUR YELLOW, CROSSWISE HOLES	E85217 ⁴	1	
48	WASHER, 10.5 FLAT ZINC	F81055-1	4	
49	BOLT, DIN933-M10X30-8.8-A2E HEX HEAD	F81003-111	2	
50	NUT, M10-8-B HEX NYLON ZINC LOCK	F81033-1	2	
51	SCREW, M4X12 5,8-B CROSS RECESSED PAN HE	F81011-43	4	

REF.	DESCRIPTION (* indicates parts available in assemblies only)	PART #	QTY	
52	NUT, M4-8 HEX NYLON ZINC LOCK	F81029-1	4	
53	WASHER, 13 FLAT ZINC	F81056-1	12	
54	BOLT, M12X35 8.8 HEX HEAD FULL THREAD ZI	F81004-24	6	
55	NUT, M12 8 HEX NYLON ZINC LOCK	F81034-2	6	
56	WASHER, 10.5 FLAT ZINC	F81055-1	8	
57	WASHER, LT15 BED LEG	085994-1	4	
58	BOLT, M10 X 80 -8.8- FE/ZN5 HEX HEAD	F81003-50	8	
59	NUT, M10-8-B HEX NYLON ZINC LOCK	F81033-1	8	
60	SHACKLE, M-D .63	086540	1	
61	TIE DOWN CHAIN ASSEMBLY	A04376-1	1	
62	LANYARD, 3/64 X 6	016030	2	
63	SCREW, M4X16 5.8-B CROSS RECESSED PAN HE	F81011-42	2	
64	WASHER, 4.3 FLAT ZINC	F81051-2	2	
65	NUT, M4-8 HEX NYLON ZINC LOCK	F81029-1	2	
-	WHEEL BOLT BALL, M12X1.5 LT15SC	550508	10	
-	BRAKE CABLE (BOWDEN CABLE)	550502	2	

¹ Not included in LT15 O2 WFL

² Not included in LT15 O2 WFL

³ Not included in LT15 O2 WFL

⁴ Not included in LT15 O2 WFL

1 PARTS LIST

Leg Set, LT15 Mobile O2

1.14 Leg Set, LT15 Mobile O2

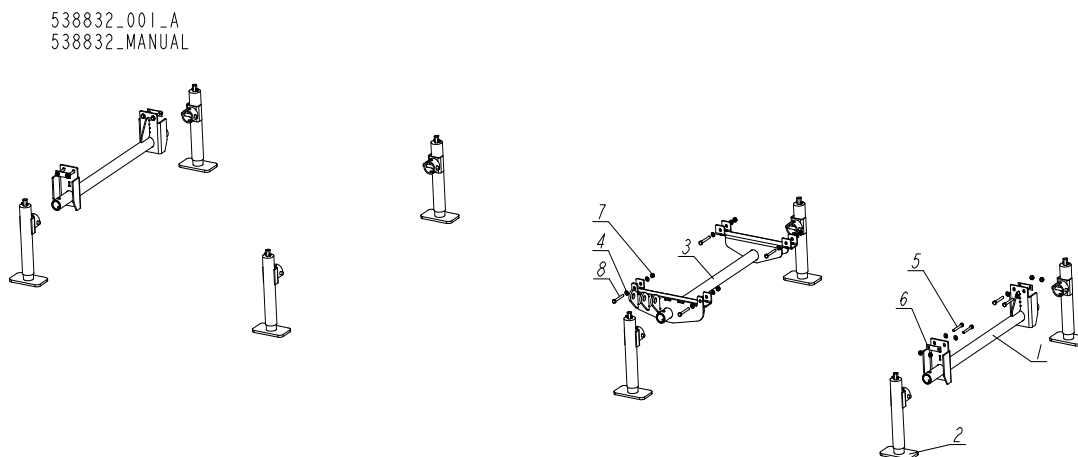

REF.	DESCRIPTION (* indicates parts available in assemblies only)	PART #	QTY
-	LEG SET, LT15 MOBILE O2	538832	1
1	TUBE WELDMENT, LEG MOUNT	538633-1	2
2	LEG, SUPPORT - COMPLETE	550455	8
	CRANK, 140X665X12 SW19 HAND COMPLETE	084536	1
3	MOUNT WELDMENT, 01 TRAILER LEG	538820-1	1
4	WASHER, 10.5 FLAT ZINC	F81055-1	16
5	BOLT, M10X75-8.8 HEX HEAD ZINC	F81003-15	8
6	WASHER, LT15 BED LEG	085994-1	4
7	NUT, M10-8-B HEX NYLON ZINC LOCK	F81033-1	12
8	BOLT, M10X80-8.8 HEX HEAD ZINC	F81003-50	4

1.15 Rear Light Beam, LT15 O2

538740_001_B
538740_MANUAL

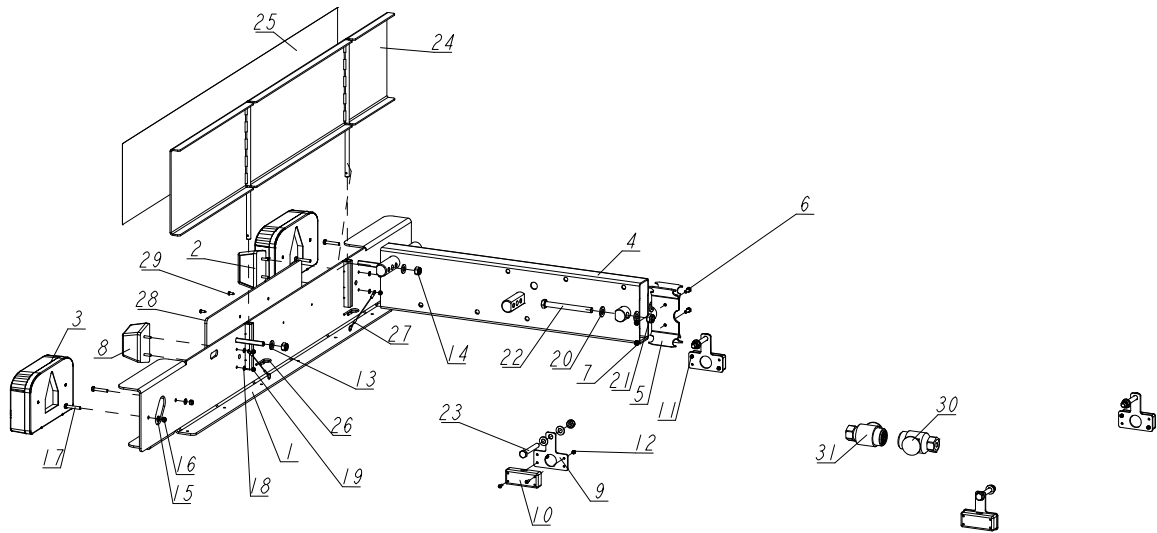

REF.	DESCRIPTION (* indicates parts available in assemblies only)	PART #	QTY
-	BEAM, LT15 O2 REAR - COMPLETE	538740	1
1	BRACKET, LIGHT BEAM	534676-1	1
2	LIGHT, FT-089 LEFT REAR	538718	1
3	LIGHT, FT-089 RIGHT REAR	538716	1
4	TUBE, MAST TRACK EXTENSION	538809-1	1
-	CONNECTOR, LT15 BED SECTION	506288	1
5	PLATE, LT15 BED SECTION CONNECTOR	506287-1	2
6	BOLT, M6 X 16 8.8 FE/ZN5 PN-M/82105	F81001-15	2
7	NUT, M6-8-B HEX NYLON ZINC LOCK	F81031-2	2
8	LIGHT, LT120 LICENCE PLATE	088597	2
-	LIGHT, MARKER - COMPLETE	538739	4
9	PLATE, FL-011 LIGHT MOUNT	538738-1	1
10	LIGHTS, CONTOUR YELLOW, CROSSWISE HOLES	E85217	1
11	SCREW, M4X12 5,8-B CROSS RECESSED PAN HE	F81011-43	2
12	NUT M4-B FE/ZN5 PN-M/82175	F81029-1	2
13	WASHER, 10.5 FLAT ZINC	F81055-1	10
14	NUT, M10-8-B HEX NYLON ZINC LOCK	F81033-1	6
15	WASHER, 6.4 FLAT ZINC	F81053-1	4
16	NUT, M6-8-B HEX NYLON ZINC LOCK	F81031-2	4
17	BOLT M6X35 8.8	F81001-71	4
18	WASHER, 5.3 FLAT ZINC	F81052-1	4
19	NUT, M5-8-FE/ZN5 DIN985	F81030-2	4

1**PARTS LIST***Rear Light Beam, LT15 O2*

REF.	DESCRIPTION (* indicates parts available in assemblies only)	PART #	QTY	
20	WASHER, 13 FLAT ZINC	F81056-1	4	
21	NUT, M12-8 HEX NYLON ZINC LOCK	F81034-2	2	
22	BOLT M12X120 8.8 FE/ZN5	F81004-38	2	
23	BOLT, M10X75-8.8-FE/ZN5 PN-M/82101	F81003-15	4	
24	PLATE	538844-1	1	
25	STICKER, 1200 X 200 MM LONG VEHICLE	538846	1	
26	PIN, 1/8 X 1 13/16 SAFETY	P05059	2	
27	LANYARD, 3/64 X 6	016030	2	
28	FRAME, LICENCE PLATE	550585	1	
29	SCREW, 4.2 X 13	F81010-1	2	

1.16 Rear Light Beam, LT15 O2 - Service Kit

534676-S_001
534676-S_MANUAL

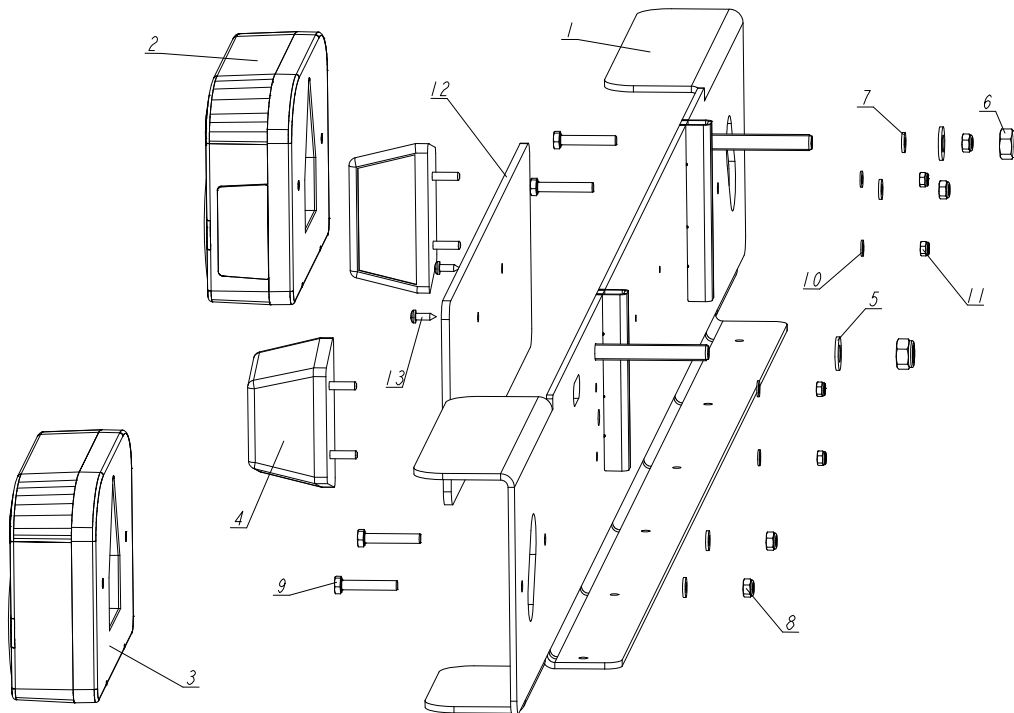

REF.	DESCRIPTION (* indicates parts available in assemblies only)	PART #	QTY
-	BEAM, LT15 O2 REAR - COMPLETE (SERVICE KIT)	534676-S	1
1	BRACKET, LIGHT BEAM	534676-1	1
2	LIGHT, FT-089 LEFT REAR	538718	1
3	LIGHT, FT-089 RIGHT REAR	538716	1
4	LIGHT, LT120 LICENCE PLATE	088597	2
5	WASHER, 10.5 FLAT ZINC	F81055-1	2
6	NUT, M10-8-B HEX NYLON ZINC LOCK	F81033-1	2
7	WASHER, 6.4 FLAT ZINC	F81053-1	4
8	NUT, M6-8-B-HEX NYLON ZINC LOCK	F81031-2	4
9	BOLT, M6X35-8.8 HEX HEAD ZINC	F81001-71	4
10	WASHER, 5,3 FLAT ZINC	F81052-1	4
11	NUT, M5-8-FE/ZN5 DIN985 NYLON LOCK	F81030-2	4
12	FRAME, LICENCE PLATE	550585	1
13	SCREW, 4.2 X 13	F81010-1	2



PARTS LIST

Drawbar w/Overrun Device, LT15 O2

1.17 Drawbar w/Overrun Device, LT15 O2

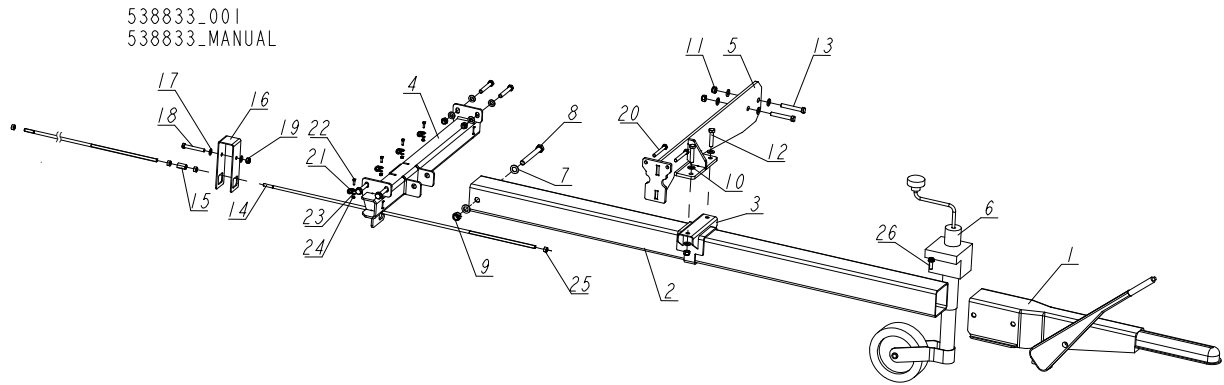

REF.	DESCRIPTION (* indicates parts available in assemblies only)	PART #	QTY
-	DRAWBAR, LT15 O2 W/OVERRUN DEVICE	538833	1
-	DRAWBAR, COMPLETE (200 622 06)	534685	1
1	DEVICE, ALKO KOBER OVERRUN (1 251 906)	S85325	1
2	TUBE, 70X70X4 SQUARE	534607	1
3	BRACKET, VKT 100 AL-KO (247 638) SADDLE	534686	1
4	BRACKET WELDMENT, DRAWBAR MOUNT	538916-1	1
5	BRACKET, DRAWBAR	534610-1	1
6	WHEEL, JOCKEY	085862	1
7	WASHER, 17 SPLIT LOCK ZINC	F81058-1	2
8	BOLT, M16X140 HEX HEAD ZINC	F81006-4	1
9	NUT, M16-8 HEX NYLON ZINC LOCK	F81036-2	1
10	WASHER, 13 FLAT ZINC	F81056-1	16
11	NUT, M12-8 DIN 982 HEX NYLON ZINC LOCK	F81034-2	8
12	BOLT, M12X55-8.8 HEX HEAD ZINC	F81004-12	2
13	BOLT, M12X80 -8.8 HEX HEAD ZINC	F81004-46	6
14	ROD, M10 L-1290MM BRAKE	538656-1	2
15	NUT, M10 DIN6334/BN1933 LONG COUPLING	F81033-19	1
16	BRACKET, BRAKE ROD	538830-1	1
17	WASHER, 10.5 FLAT ZINC	F81055-1	10
18	BOLT, M10X75-8.8 HEX HEAD ZINC	F81003-15	1
19	NUT, M10-8-B HEX NYLON ZINC LOCK	F81033-1	5
20	BOLT, M10X85-8.8 HEX HEAD ZINC	F81003-125	2
21	CLIP, RSGU 1.10/12 W1 RETAINING	086861	4
22	BOLT, M5 X 16-8.8 HEX HEAD FULL THREAD ZINC	F81000-20	4
23	WASHER, 5.3 FLAT ZINC	F81052-1	4
24	NUT, M5-8 DIN985 HEX NYLON ZINC LOCK	F81030-2	4
25	NUT, M10 8 HEX ZINC	F81033-3	4
26	SCREW, DIN933-M10X30-8.8-A2E HEX CAP FULL THREAD	F81003-111	4

1.18 Drawbar w/Overrun Device, LT15 O2 WFL

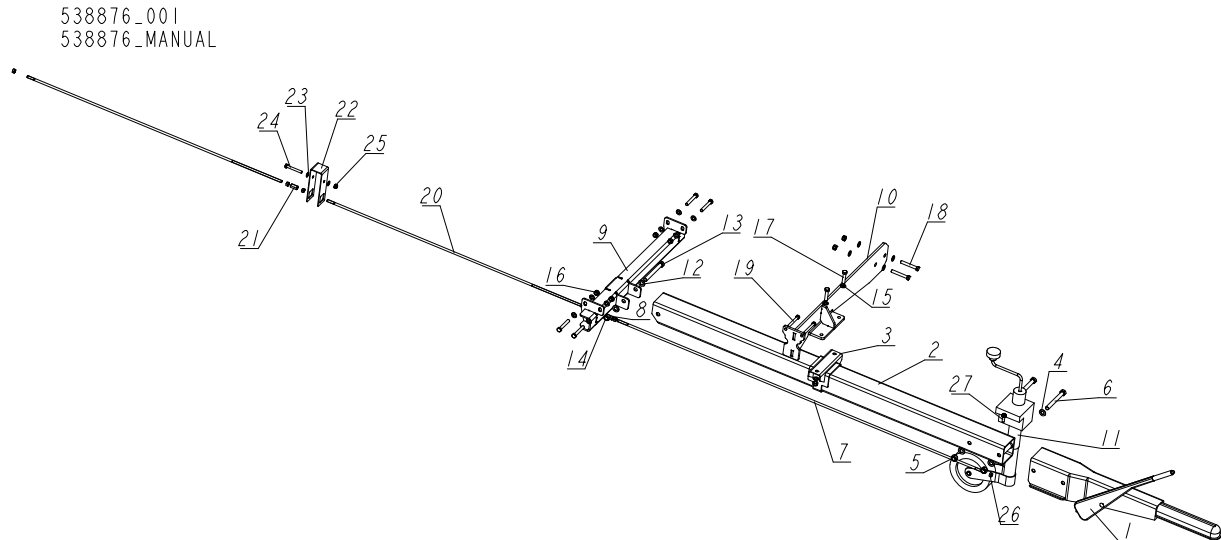

REF.	DESCRIPTION (* indicates parts available in assemblies only)	PART #	QTY
-	DRAWBAR, LT15 O2 WFL W/OVERRUN DEVICE	538876	1
-	COMPLETE DRAWBAR	538871	1
1	DEVICE, ALKO KOBER OVERRUN (1 251 906)	S85325	1
2	DRAWBAR, O2 WFL	538874-1	1
3	BRACKET, VKT 100 AL-KO (247 638) SADDLE	534686	1
4	WASHER, 17 FLAT ZINC	F81058-1	4
5	NUT, M16-8 HEX NYLON ZINC LOCK	F81036-2	2
6	BOLT, M16X140 HEX HEAD ZINC	F81006-4	2
7	ROD, M10 L-1850MM BRAKE	538875-1	1
8	NUT, M10 DIN6334/BN1933 LONG COUPLING	F81033-19	1
9	BRACKET WELDMENT, DRAWBAR MOUNT	538916-1	1
10	BRACKET, DRAWBAR	534610-1	1
11	WHEEL, JOCKEY	085862	1
12	WASHER, 17 FLAT ZINC	F81058-1	2
13	BOLT, M16X140 HEX HEAD ZINC	F81006-4	1
14	NUT, M16-8 HEX NYLON ZINC LOCK	F81036-2	1
15	WASHER, 13 FLAT ZINC	F81056-1	16
16	NUT, M12-8 DIN 982 HEX NYLON ZINC LOCK	F81034-2	8
17	BOLT, M12X55-8.8 HEX HEAD ZINC	F81004-12	2
18	BOLT, M12X80-8.8 HEX HEAD ZINC	F81004-46	6
19	BOLT, M10X85-8.8 HEX HEAD ZINC	F81003-125	2
20	ROD, M10 L-1290MM BRAKE	538656-1	2
21	NUT, M10 DIN6334/BN1933 LONG COUPLING	F81033-19	1
22	BRACKET, BRAKE ROD	538830-1	1
23	WASHER, 10.5 FLAT ZINC	F81055-1	10
24	BOLT, M10X75-8.8 HEX HEAD ZINC	F81003-15	1
25	NUT, M10-8-B HEX NYLON ZINC LOCK	F81033-1	5

1**PARTS LIST***Drawbar w/Overrun Device, LT15 O2 WFL*

REF.	DESCRIPTION (* indicates parts available in assemblies only)	PART #	QTY	
26	NUT, M10 8 HEX ZINC	F81033-3	6	
27	SCREW, DIN933-M10X30-8.8-A2E HEX CAP FULL THREAD	F81003-111	4	

1.19 Blade Height Scale, LT15 O2

538834_001
538834_MANUAL

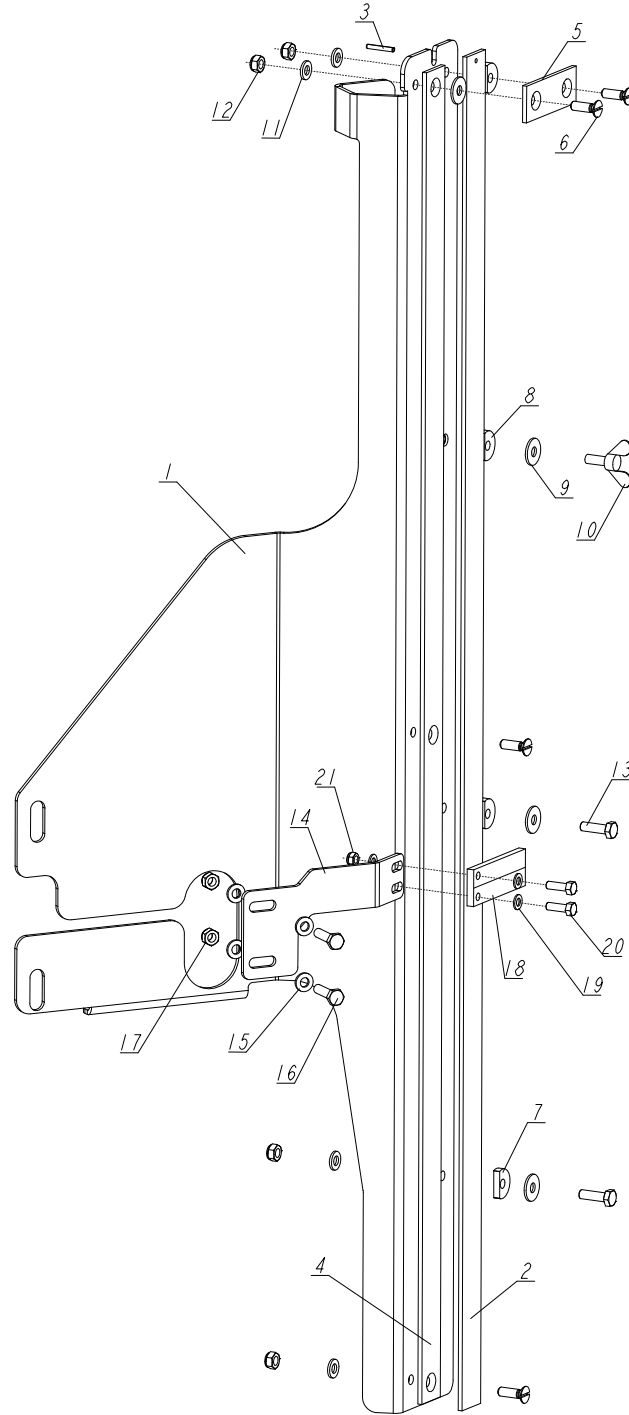

REF.	DESCRIPTION (* indicates parts available in assemblies only)	PART #	QTY
-	SCALE ASSEMBLY, LT15 O2 BLADE HEIGHT	538834	1
-	BASE, BLADE HEIGHT SCALE - COMPLETE	538648	1
1	BRACKET WELDMENT, BLADE HEIGHT SCALE	538848-1	1
2	BAR, INCH SCALE	093133	1

1**PARTS LIST***Blade Height Scale, LT15 O2*

REF.	DESCRIPTION (* indicates parts available in assemblies only)	PART #	QTY	
3	PIN, 3X20 GEOMET ROLL	F81044-5	1	
4	BAR, SCALE	092750	1	
5	BAR, SCALE CLAMP	093134	1	
6	SCREW, M6X20-5.8-B SLOTTED COUNTERSUNK HEAD ZINC	F81001-31	4	
7	WASHER, 6.2X20X4.5 SPECIAL	503098	3	
8	WASHER, 6.2X20X3.5 SPECIAL	503096	1	
9	WASHER, 6.5 SPECIAL FLAT ZINC	F81053-11	4	
10	SCREW, M6X16 DIN-316/BN-276 ZINC-PL. WING	F81001-16	1	
11	WASHER, 6.4 FLAT ZINC	F81053-1	6	
12	NUT, M6-8-B HEX NYLON ZINC LOCK	F81031-2	6	
13	BOLT, M6X20 8.8 HEX HEAD FULL THREAD ZINC	F81001-2	2	
14	BRACKET, SCALE INDICATOR	538650-1	1	
15	WASHER, 6.4 FLAT ZINC	F81053-1	4	
16	BOLT, M6X25-8.8 HEX HEAD FULL THREAD ZINC	F81001-3	2	
17	NUT, M6-8-B HEX NYLON ZINC LOCK	F81031-2	2	
18	INDICATOR, BLADE HEIGHT SCALE	094821	1	
19	WASHER, 5.3 FLAT ZINC	F81052-1	4	
20	BOLT, M5 X 16-8.8 HEX HEAD FULL THREAD ZINC	F81000-20	2	
21	NUT, M5-8 DIN985 HEX NYLON ZINC LOCK	F81030-2	2	

1.20 Additional Equipment (LT15 O2)

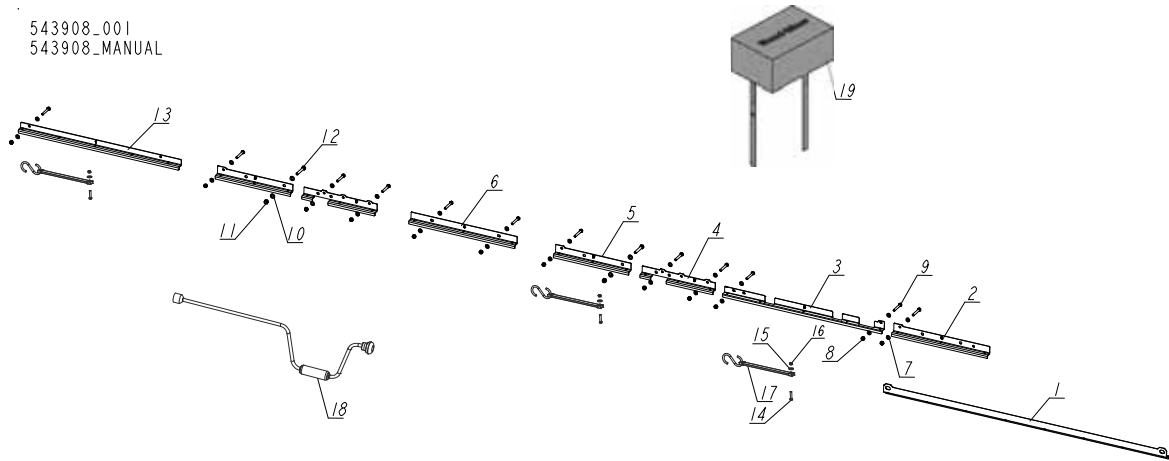

REF.	DESCRIPTION (* indicates parts available in assemblies only)	PART #	QTY
-	DUCT SET, CABLE - COMPLETE	543908	1
1	DUCT, CABLE (1)	543907-1	1
2	DUCT, CABLE (3)	543905-1	1
3	PLATE	538792-1	1
4	DUCT, CABLE (5)	543903-1	2
5	DUCT, CABLE (6)	543902-1	2
6	DUCT, CABLE (4)	543904-1	1
7	WASHER, 10.5 FLAT ZINC	F81055-1	24
8	NUT, M10-8-B HEX NYLON ZINC LOCK	F81033-1	12
9	BOLT, M10X70 8.8 HEX HEAD FULL THREAD ZINC	F81003-20	12
10	WASHER, 13 FLAT ZINC	F81056-1	4
11	NUT, M12-8 DIN 982 HEX NYLON ZINC LOCK	F81034-2	2
12	BOLT, M12X75-8.8 DIN 933 HEX HEAD FULL THREAD ZINC	F81004-10	2
13	PLATE	538923-1	1
	STRAP, CLAMP TRANSPORT LOCK	538835	1
14	STRAP, 9" RUBBER WITH HOOKS	012965	3
15	WASHER, 6.5 SPECIAL FLAT ZINC	F81053-11	3
16	BOLT, M6x30-8.8 HEX HEAD FULL THREAD ZINC	F81001-8	3
17	NUT, M6-8-B HEX NYLON ZINC LOCK	F81031-2	3
18	HANDLE, HKB SW 19-L660 (W 4460) CRANK - COMPLETE	084536	1
19	COVER, 35X25X15 CONTROL BOX	550414	1

1 PARTS LIST

Individual Homologation Kit, LT15SC (optional)

1.21 Individual Homologation Kit, LT15SC (optional)

550478_001
550478_MANUAL

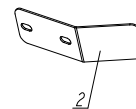
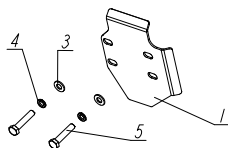

REF.	DESCRIPTION (* indicates parts available in assemblies only)	PART #	QTY	
-	INDIVIDUAL HOMOLOGATION KIT, LT15SC	550478	1	
1	CAP, TUBE END	550457-1	1	
2	GUARD	550456-1	1	
3	WASHER, 10.5 FLAT ZINC	F81055-1	2	
4	WASHER, 10.2 SPLIT LOCK ZINC	F81055-2	2	
5	BOLT, M10X50-8.8 HEX HEAD FULL THREAD ZINC	F81003-4	2	

1.22 LT15 Manual Log Turner (Optional)

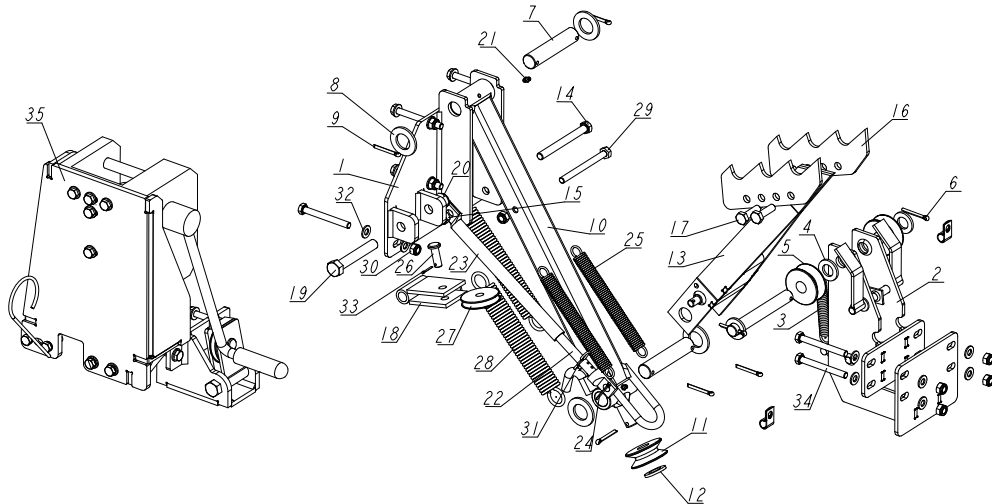
538960_001
538960_MANUAL

REF.	DESCRIPTION (* indicates parts available in assemblies only)	PART #	QTY
-	TURNER, LT15 MANUAL LOG - COMPLETE	538960	1
1	BRACKET WELDMENT, LT15 MANUAL LOG TURNER	538959-1	1
-	BRACKET, MANUAL LOG TURNER CABLE - COMPLETE	538972	1
2	BRACKET WELDMENT, TURNER CABLE	538974-1	1
3	SPRING, N1.9 N20X114.3 (U.200.190.1143.AX) EXTENSION	538975	1
4	WASHER, 21 FLAT ZINC	F81059-2	4
5	SHEAVE, ZINC-PLATED	091280-1	2
6	PIN, S-FE 5X40 COTTER	F81043-31	2
7	PIN, MANUAL TURNER ARM PIVOT ZINC-PL.	091275-1	2
8	WASHER, 28 FLAT ZINC	F81061-1	4
9	PIN, S-FE 5X40 COTTER	F81043-31	5
10	ARM WELDMENT, LT15 MANUAL TURNER - LOWER	538962-1	1
11	SHEAVE, ZINC-PLATED	091280-1	1
12	WASHER, 21 FLAT ZINC	F81059-2	1
13	ARM WELDMENT, LT15 MANUAL TURNER - UPPER	538964-1	1
14	BOLT, M12X120-8.8 HEX HEAD ZINC	F81004-38	1
15	NUT, M12-8 DIN 982 HEX NYLON ZINC LOCK	F81034-2	3
16	CLAW, LOG TURNER	088082-OLD	2
17	BOLT, M12X40-8.8 HEX HEAD FULL THREAD ZINC	F81004-4	2
18	BRACKET WELDMENT, CABLE GUIDE PULLEY	091295-1	1
19	BOLT, M16X100-8.8 HEX HEAD FULL THREAD ZINC	F81006-2	1
20	NUT, M16-8 HEX NYLON ZINC LOCK	F81036-2	1
21	FITTING, M6 TYPE A STRAIGHT GREASE	086280	2
22	ROD WELDMENT, COMPLETE	538968-1	1
23	TUBE	538969-1	1
24	PIN, S-ZN 4X25 COTTER	F81043-2	1

1**PARTS LIST***LT15 Manual Log Turner (Optional)*

REF.	DESCRIPTION (* indicates parts available in assemblies only)	PART #	QTY	
25	SPRING, N2.8XN22.2X183	091864	2	
26	PIN, B-12X35-FS/ZN5	F81049-1	1	
27	PULLEY, CABLE GUIDE ZINC-PLATED	091273-1	1	
28	SPRING, N4.5XN40X236 (T_400_450_2360_A)	538971	2	
29	BOLT, M10X115-8.8 HEX HEAD	F81003-19	1	
30	NUT, M10-8-B HEX NYLON ZINC LOCK	F81033-1	10	
31	PIN, 1/8X1 13/16 SAFETY	P05059	1	
32	WASHER, 10.5 ZINC FLAT	F81055-1	18	
33	PIN, S-ZN-2.5X20 COTTER	F81043-1	1	
34	BOLT, M10X90-8.8-B HEX HEAD ZINC	F81003-66	9	
35	COMPLETE WINCH	538991	1	

1.23 Saw Head Safety Belt

527064_001
527064_MANUAL

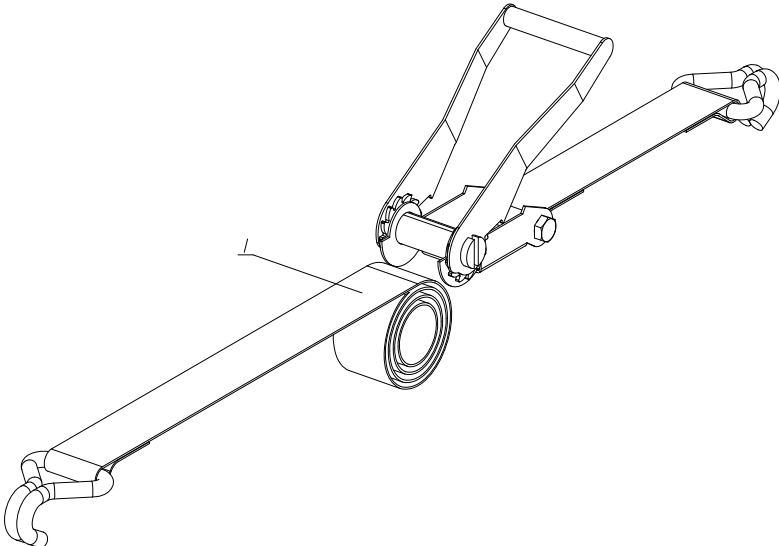

REF.	DESCRIPTION (* indicates parts available in assemblies only)	PART #	QTY	
1	BELT, SAW HEAD SAFETY	527064	1	

1

PARTS LIST

Axle Assembly, Trailer for LT15 Wide

1.24 Axle Assembly, Trailer for LT15 Wide

550501_001_A
550501_MANUAL

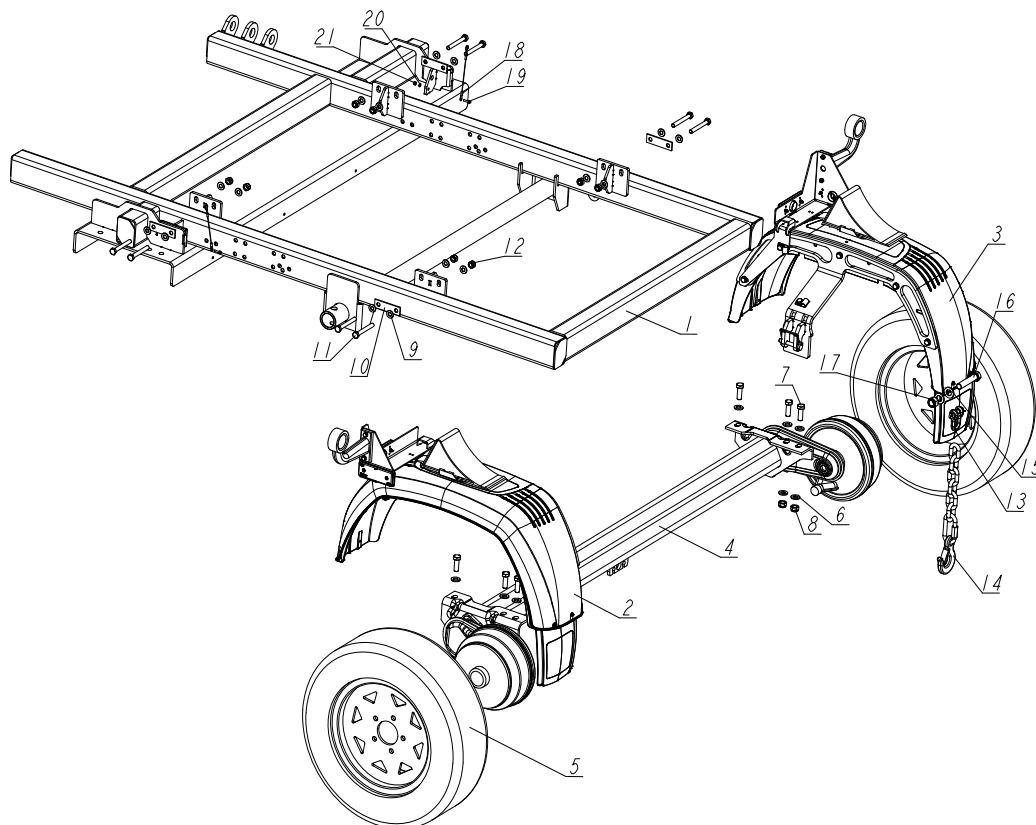

REF.	DESCRIPTION (* indicates parts available in assemblies only)	PART #	QTY
-	AXLE, LT15 WIDE TRAILER - COMPLETE	550501	1
1	FRAME, LT15 WIDE TRAILER	550450-1	1
2	FENDER, LEFT - COMPLETE See Section 1.27	550595	1
3	FENDER, RIGHT - COMPLETE See Section 1.26	550596	1
4	AXLE, AL-KO DMC-1500; A-1400; C- 1850 (2	550805	1
5	COMPLETE WHEEL, 155/70 R12 ET20/30 112X5	534597	2
6	WASHER, 13 FLAT ZINC	F81056-1	12
7	BOLT, M12X35 8.8 HEX HEAD FULL THREAD ZI	F81004-24	6
8	NUT, M12 8 HEX NYLON ZINC LOCK	F81034-2	6
9	WASHER, 10.5 FLAT ZINC	F81055-1	16
10	WASHER, LT15 BED LEG	085994-1	4
11	BOLT, M10 X 80 -8.8- FE/ZN5 HEX HEAD	F81003-50	8
12	NUT, M10-8-B HEX NYLON ZINC LOCK	F81033-1	8
13	SHACKLE, M-D 63	086540	1
14	TIE DOWN CHAIN ASSEMBLY	A04376-1	1
15	WASHER, 17 SPLIT LOCK ZINC	F81058-1	2
16	BOLT, M16X80 8.8-B- HEX HEAD FULL THREAD	F81006-11	1
17	NUT, M16-8-HEX NYLON ZINC LOCK	F81036-2	1

PARTS LIST*Axle Assembly, Trailer for LT15 Wide***1**

REF.	DESCRIPTION (* indicates parts available in assemblies only)	PART #	QTY	
18	LANYARD, 3/64 X 6	016030	2	
19	SCREW, M4X16 5.8-B CROSS RECESSED PAN HE	F81011-42	2	
20	WASHER, 4.3 FLAT ZINC	F81051-2	2	
21	NUT, M4-8 HEX NYLON ZINC LOCK	F81029-1	2	
-	WHEEL BOLT BALL, M12X1.5 LT15SC	550508	10	
-	BRAKE CABLE (BOWDEN CABLE)	550502	2	

1

PARTS LIST

Axle Assembly, Trailer for LT15 Wide - WFL version

1.25 Axle Assembly, Trailer for LT15 Wide - WFL version

550826_001
550826_MANUAL

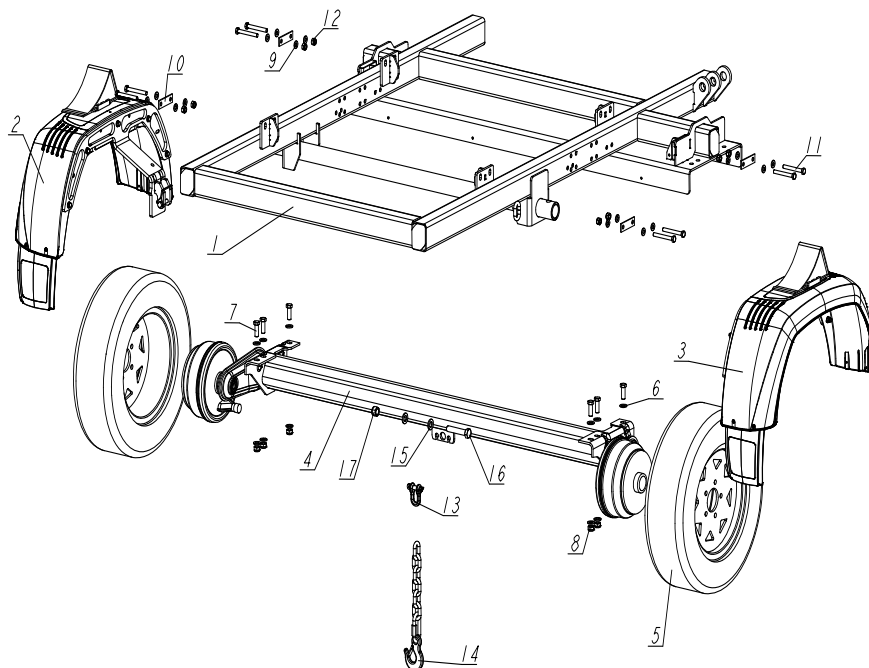

REF.	DESCRIPTION (* indicates parts available in assemblies only)	PART #	QTY
-	AXLE, LT15 WIDE TRAILER WFL - COMPLETE	550826	1
1	FRAME, LT15 WIDE TRAILER	550450-1	1
2	FENDER, LEFT - COMPLETE See Section 1.27	550827	1
3	FENDER, RIGHT - COMPLETE See Section 1.27	550828	1
4	AXLE, AL-KO DMC-1500; A-1400; C- 1850 (2)	550805	1
5	COMPLETE WHEEL, 155/70 R12 ET20/30 112X5	534597	2
6	WASHER, 13 FLAT ZINC	F81056-1	12
7	BOLT, M12 X 35-8.8 HEX HEAD FULL THREAD	F81004-24	6
8	NUT, M12 8 HEX NYLON ZINC LOCK	F81034-2	6
9	WASHER 10,5 ZC DIN 126 ISO 7091	F81055-1	16
10	WASHER, LT15 BED	085994-1	4
11	BOLT, M10 X 80 -8.8- FE/ZN5 HEX HEAD	F81003-50	8
12	NUT, M10-8-B HEX NYLON ZINC LOCK	F81033-1	8
13	SHACKLE, M-D 63	086540	1
14	CHAIN, LOG LOADER SAFETY	A04376-1	1
15	WASHER, 17 FLAT ZINC	F81058-1	2
16	BOLT, M16X80 8.8-B- HEX HEAD FULL THREAD	F81006-11	1
17	NUT, M16-8 HEX NYLON ZINC LOCK	F81036-2	1
-	WHEEL BOLT BALL, M12X1.5 LT15SC	550508	10
-	BRAKE CABLE (BOWDEN CABLE)	550502	2

1.26 Fender with Mount Bracket - Right, Trailer for LT15 Wide

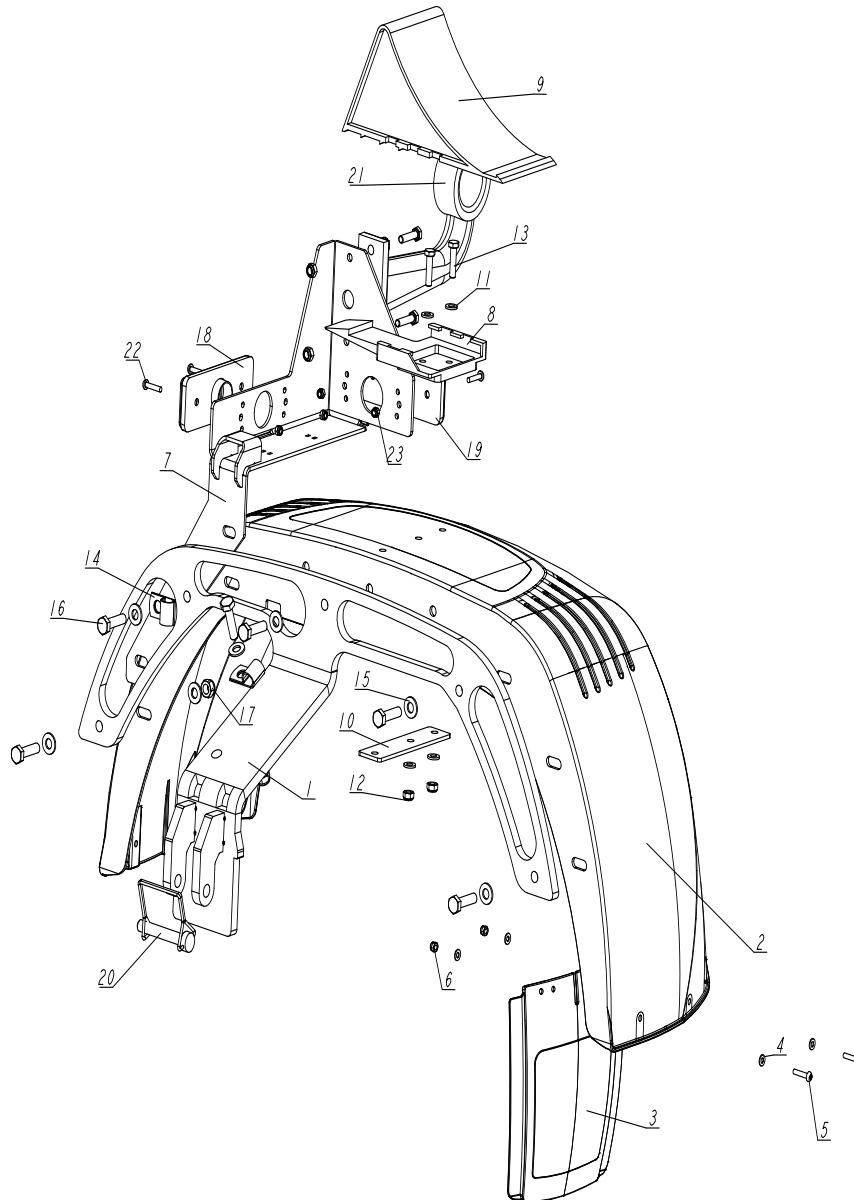
550596_001_A
550596_MANUAL

REF.	DESCRIPTION (* indicates parts available in assemblies only)	PART #	QTY
-	FENDER, RIGHT - COMPLETE	550596	1
1	MOUNT WELDMENT, FENDER - RIGHT	550504-1	1
-	FENDER, 200MM (1 259 347) W/MUD FLAP - L	538907	1
2	FENDER, AL-KO EA200 (1 259 576)	538909	1
3	MUD FLAP, 200MM (1 258 651)	538824	1
4	WASHER, 4.3 ZINC FLAT	F81051-2	4
5	SCREW, ISO 7045-M4X20-4.8-H-A2 CROSS REC	F81011-46	2

1**PARTS LIST***Fender with Mount Bracket - Right, Trailer for LT15 Wide*

REF.	DESCRIPTION (* indicates parts available in assemblies only)	PART #	QTY	
6	NUT, M4-B HEX NYLON ZINC LOCK	F81029-1	2	
7	BRACKET, LIGHT MOUNT RIGHT	550521-1	1	
8	HANDLE, TRAILER WEDGE STOP	P85106	1	
9	WEDGE, TIRE, TRAILER STOP	P85105	1	
10	PLATE	550413-1	1	
11	WASHER, 6.4 FLAT ZINC	F81053-1	6	
12	NUT, M6-8-B NYLON HEX ZINC LOCK	F81031-2	4	
13	BOLT, M6X25-5.8 HEX HEAD FULL THREAD ZIN	F81001-3	4	
14	CLAMP, 1/2" EMT COATED	P07584	2	
15	WASHER, 8.4 FLAT ZINC	F81054-1	12	
16	BOLT, M8X30-8.8-B HEX HEAD FULL THREAD Z	F81002-7	6	
17	NUT, M8-8-B HEX NYLON ZINC LOCK	F81032-2	6	
18	LED MARKER LIGHT, WHITE, RECTANGULAR LD 160/4	550564	1	
19	LED MARKER LIGHT, ORANGE, RECTANGULAR LD 161/4	550565	1	
20	PIN, 3/8 X 2 1/4 SQ WIRE LOCK	014151	1	
21	LD 724/P – MARKER LIGHT, WHITE-RED. HOR. 69, RIGHT	550567	1	
22	SCREW, ISO 7045-M4X20-4.8-H-A2 CROSS REC	F81011-46	4	
23	NUT, M4-B HEX NYLON ZINC LOCK	F81029-1	4	

1.27 Fender with Mount Bracket - Left, Trailer for LT15 Wide

550595_001_A
550595_MANUAL

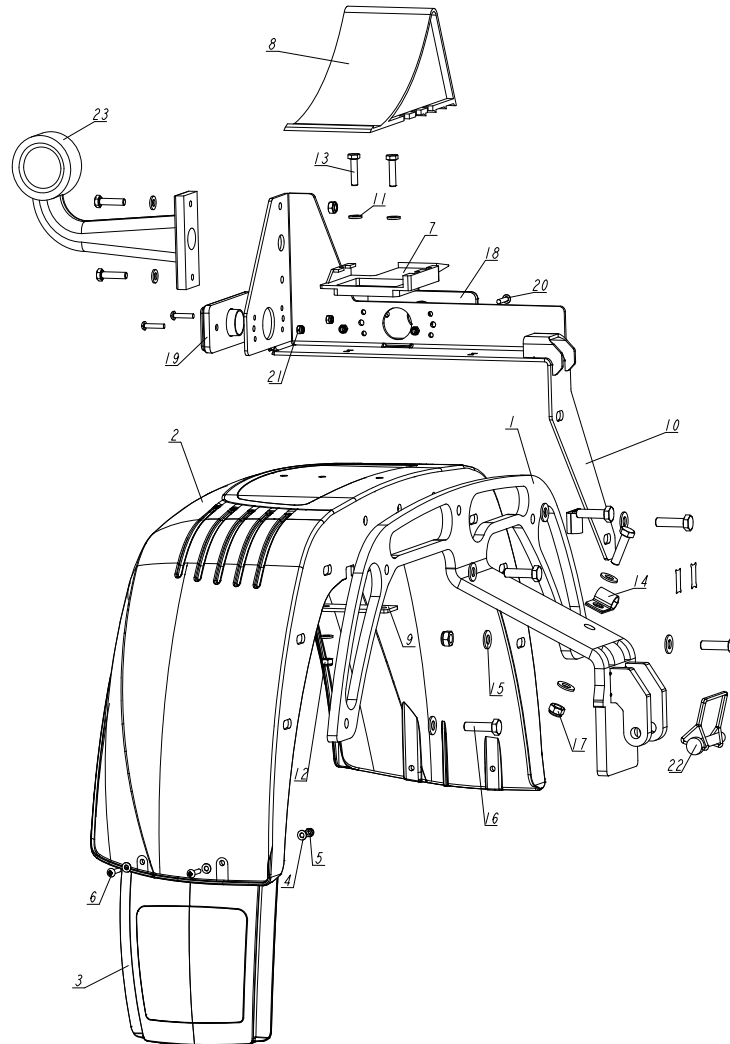

REF.	DESCRIPTION (* indicates parts available in assemblies only)	PART #	QTY
-	FENDER, LEFT - COMPLETE	550595	1
1	MOUNT WELDMENT, FENDER - LEFT	550509-1	1
-	FENDER, 200MM P (1 259 580) W/MUD FLAP	538906	1
2	FENDER, AL-KO EA200 (1 259 576)	538909	1
3	MUD FLAP, 200MM (1 258 651)	538824	1
4	WASHER, 4.3 ZINC FLAT	F81051-2	4
5	NUT, M4-B HEX NYLON ZINC LOCK	F81029-1	2
6	SCREW, ISO 7045-M4X20-4.8-H-A2 CROSS REC	F81011-46	2
7	HANDLE, TRAILER WEDGE STOP	P85106	1
8	WEDGE, TIRE, TRAILER STOP	P85105	1
9	PLATE	550413-1	1
10	BRACKET, LIGHT MOUNT LEFT	550520-1	1

1**PARTS LIST***Fender with Mount Bracket - Left, Trailer for LT15 Wide*

REF.	DESCRIPTION (* indicates parts available in assemblies only)	PART #	QTY	
11	WASHER, 6.4 FLAT ZINC	F81053-1	6	
12	NUT, M6-8-B NYLON HEX ZINC LOCK	F81031-2	4	
13	BOLT, M6X25-5.8 HEX HEAD FULL THREAD ZINC	F81001-3	4	
14	CLAMP, 1/2" EMT COATED	P07584	2	
15	WASHER, 8.4 FLAT ZINC	F81054-1	12	
16	BOLT, M8X30-8.8-B HEX HEAD FULL THREAD ZINC	F81002-7	6	
17	NUT, M8-8-B HEX NYLON ZINC LOCK	F81032-2	6	
18	LED MARKER LIGHT, WHITE, RECTANGULAR LD 160/4	550564	1	
19	LED MARKER LIGHT, ORANGE, RECTANGULAR LD 161/4	550565	1	
20	SCREW, ISO 7045-M4X20-4.8-H-A2 CROSS REC	F81011-46	4	
21	NUT, M4-B HEX NYLON ZINC LOCK	F81029-1	4	
22	PIN, 3/8 X 2 1/4 SQ WIRE LOCK	014151	1	
23	LD 724/L – MARKER LIGHT, WHITE-RED. HOR. 69, LEFT	550566	1	

1.28 Fender with Mount Bracket, Trailer for LT15 Wide, WFL version

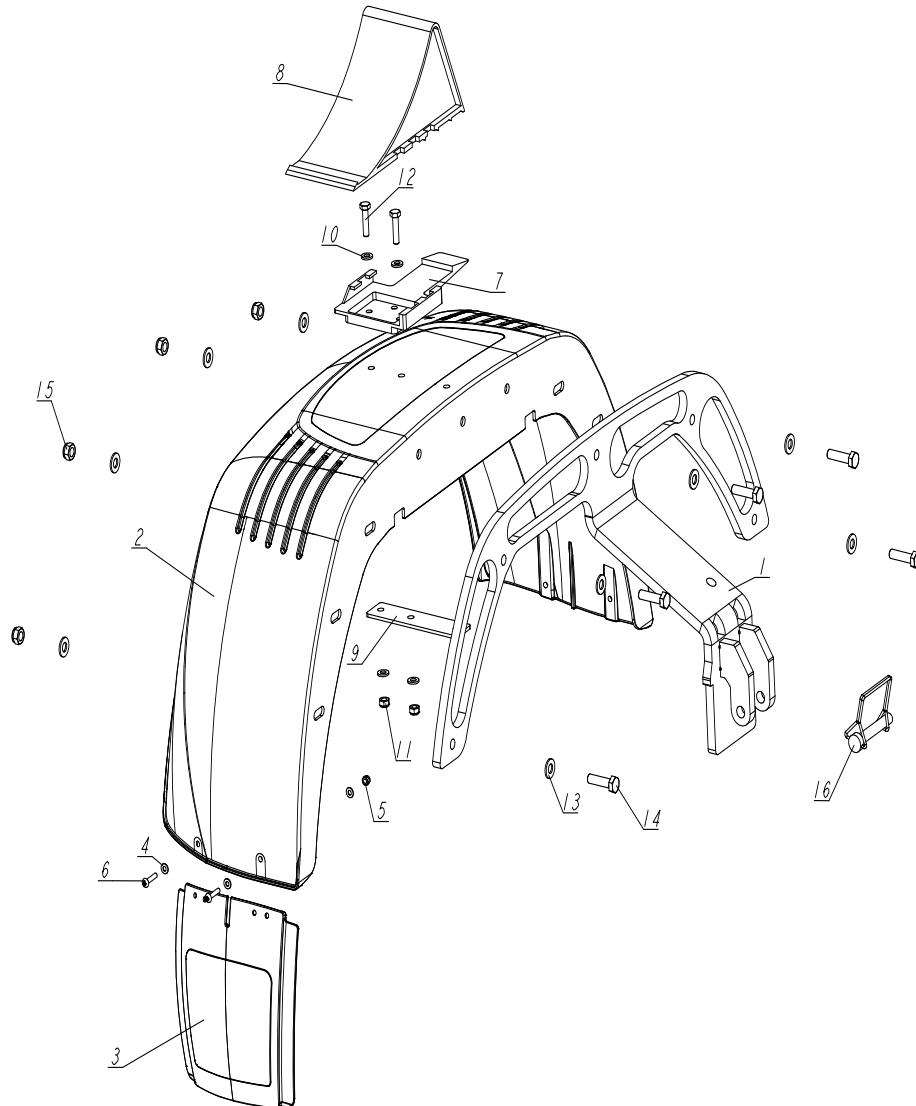
550827_001
550827_MANUAL

REF.	DESCRIPTION (* indicates parts available in assemblies only)	PART #	QTY
-	FENDER, LEFT - COMPLETE, WFL VERSION	550827	1
	FENDER, RIGHT - COMPLETE, WFL VERSION	550828	1
1	MOUNT WELDMENT, FENDER - LEFT, LT15 WIDE TRAILER, WFL VERSION	550509-1	1
	MOUNT WELDMENT, FENDER - RIGHT, LT15 WIDE TRAILER, WFL VERSION	550504-1	1
-	FENDER, 200MM P (1 259 580) W/MUD FLAP	538906	1
	FENDER, 200MM (1 259 347) W/MUD FLAP - L	538907	1
2	FENDER, AL-KO EA200 (1 259 576)	538909	1
3	MUD FLAP, 200MM (1 258 651)	538824	1
4	WASHER, 4.3 FLAT ZINC	F81051-2	4
5	NUT, M4-8 HEX NYLON ZINC LOCK	F81029-1	2

1**PARTS LIST***Fender with Mount Bracket, Trailer for LT15 Wide, WFL version*

REF.	DESCRIPTION (* indicates parts available in assemblies only)	PART #	QTY	
6	SCREW, ISO 7045-M4X20-4.8-H-A2 CROSS REC	F81011-46	2	
7	HANDLE, TRAILER WEDGE STOP	P85106	1	
8	WEDGE, TIRE, TRAILER STOP	P85105	1	
9	PLATE	550413-1	1	
10	WASHER, 6.4 FLAT ZINC	F81053-1	4	
11	NUT, M6-8-B HEX NYLON ZINC LOCK	F81031-2	2	
12	BOLT, M6X25 -8.8 HEX HEAD FULL THREAD ZI	F81001-3	2	
13	WASHER, 8.4 FLAT ZINC	F81054-1	10	
14	BOLT M8X30 HH ZC FT 8.8 DIN 933	F81002-7	5	
15	NUT, M8-8-B HEX NYLON ZINC LOCK	F81032-2	5	
16	PIN, 3/8 X 2 1/4 SQ WIRE LOCK	014151	1	

1.29 Leg Set, Trailer for LT15 Wide

550522_001_A
 550522_MANUAL

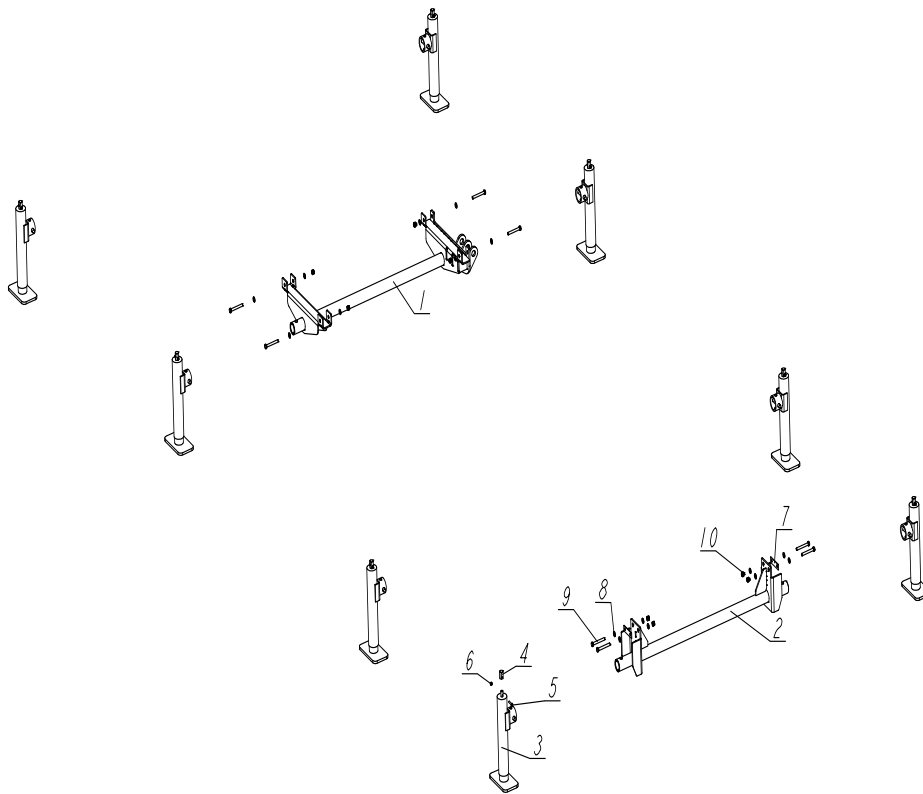

REF.	DESCRIPTION (* indicates parts available in assemblies only)	PART #	QTY
-	LEG SET, TRAILER FOR LT15 WIDE	550522	1
1	MOUNT WELDMENT, LT15 WIDE TRAILER LEG	550494-1	1
2	TUBE WELDMENT, LEG MOUNT LT15 WIDE TRAILER	550495-1	1
-	LEG, SUPPORT - COMPLETE	550455	8
3	LEG, SUPPORT - MOBILE SAWMILLS	110403	1
4	ADAPTER, SUPPORT LEG	550454-1	1
5	BOLT, M6X30-8.8 HEX HEAD FULL THREAD ZIN	F81001-8	1
6	NUT, M6-8-B NYLON HEX ZINC LOCK	F81031-2	1
7	WASHER, LT15 BED	085994-1	2
8	WASHER, 10.5 FLAT ZINC	F81055-1	16
9	BOLT, M10 X 80 -8.8- FE/ZN5 HEX HEAD	F81003-50	8
10	NUT, M10-8-B HEX NYLON ZINC LOCK	F81033-1	8



PARTS LIST

Rear Light Beam, Trailer for LT15 Wide

1.30 Rear Light Beam, Trailer for LT15 Wide

550597_001
550597_MANUAL

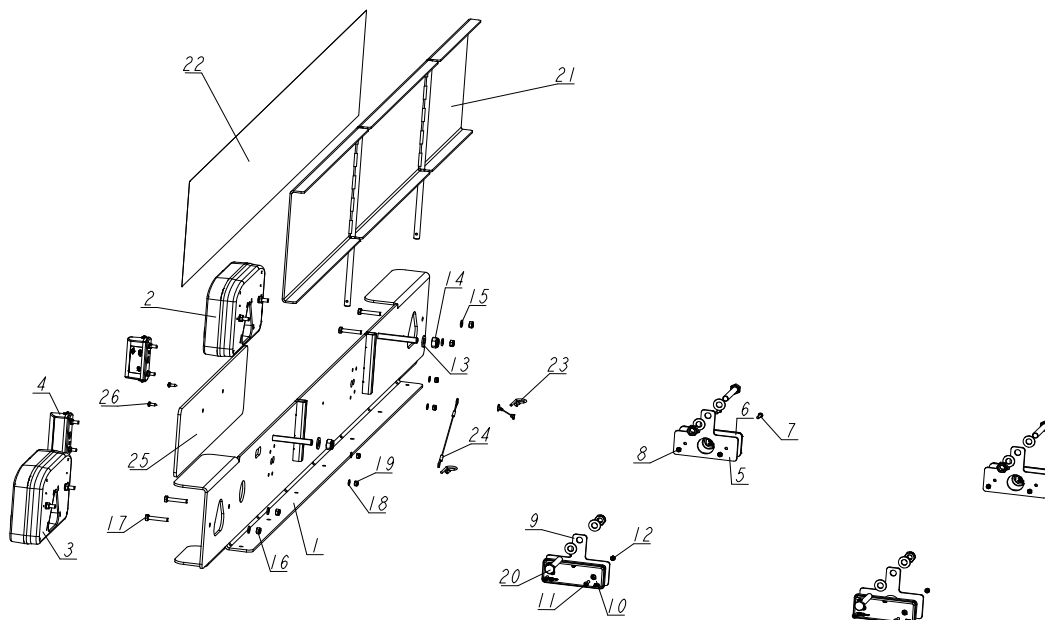

REF.	DESCRIPTION (* indicates parts available in assemblies only)	PART #	QTY
-	REAR LIGHT BEAM, TRAILER FOR LT15 WIDE	550597	1
1	BRACKET, LIGHT BEAM	550513-1	1
2	LZD 845 – REAR LIGHT, LEFT	550570	1
3	LZD 844 – REAR LIGHT, RIGHT	550569	1
4	LTD 665 – LIGHT - LICENCE PLATE, SMALL HOR 63, 12/24V	550568	2
-	LIGHT, MARKER - COMPLETE	550598	2
5	PLATE, LIGHT MOUNT HOR 42	550599-1	1
6	LED MARKER LIGHT, ORANGE, RECTANGULAR LD 161/4	550565	1
7	SCREW, ISO 7045-M4X20-4.8-H-A2 CROSS REC	F81011-46	2
8	NUT, M4-B HEX NYLON ZINC LOCK	F81029-1	2
-	LIGHT, MARKER - WIRE, 1,5M - COMPLETE	550598-L	2
9	PLATE, LIGHT MOUNT HOR 42	550599-1	1
10	LED MARKER LIGHT, ORANGE, RECTANGULAR LD 161/4 L	550565-L	1
11	SCREW, ISO 7045-M4X20-4.8-H-A2 CROSS REC	F81011-46	2
12	NUT, M4-B HEX NYLON ZINC LOCK	F81029-1	2
13	WASHER, 10.5 FLAT ZINC	F81055-1	10
14	NUT, M10-8-B HEX NYLON ZINC LOCK	F81033-1	6
15	WASHER, 6.4 FLAT ZINC	F81053-1	4
16	NUT, M6-8-B NYLON HEX ZINC LOCK	F81031-2	4
17	BOLT, M6X35 8.8 HEX HEAD ZINC	F81001-71	4
18	WASHER, 5.3 FLAT ZINC	F81052-1	4
19	NUT, M5-8-FE/ZN5 DIN985	F81030-2	4
20	BOLT, M10X75-8.8-HEX HEAD ZINC	F81003-15	4

PARTS LIST*Rear Light Beam, Trailer for LT15 Wide***1**

REF.	DESCRIPTION (* indicates parts available in assemblies only)	PART #	QTY	
21	PLATE, REFLECTIVE STICKER	550517-1	1	
22	STICKER, LONG VEHICLE MARKING 1400X200	550518	1	
23	PIN, 1/8X1 13/16 SAFETY	P05059	2	
24	LANYARD, 3/64 X 6	016030	2	
25	FRAME, LICENCE PLATE	550585	1	
26	SCREW, 4.2 X 13	F81010-1	2	

1

PARTS LIST

Drawbar with Overrun Device, Trailer for LT15 Wide

1.31 Drawbar with Overrun Device, Trailer for LT15 Wide

550499_001
550499_MANUAL

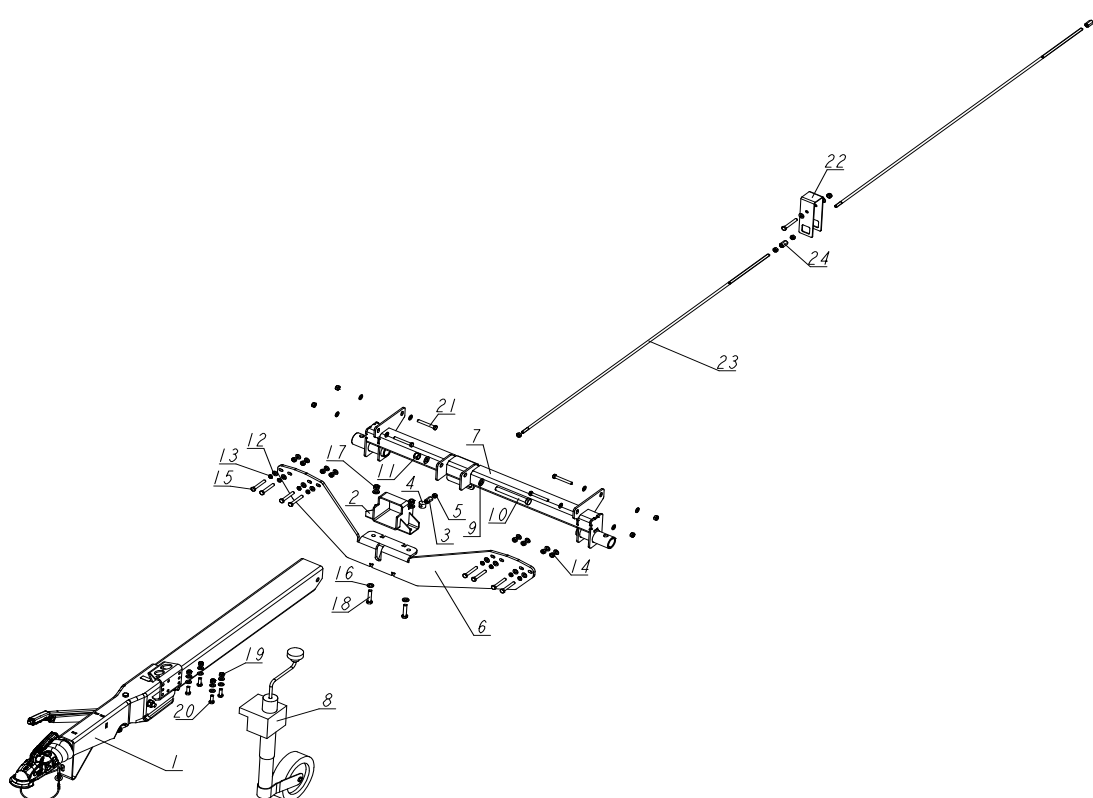

REF.	DESCRIPTION (* indicates parts available in assemblies only)	PART #	QTY
-	DRAWBAR, LT15 WIDE TRAILER W/OVERRUN DEVICE	550499	1
-	DRAWBAR - COMPLETE L=1850 (200 622 02)	550490	1
1	DRAWBAR	20062202	1
2	BRACKET, VKT 100 AL-KO (247 638) SADDLE	534686	1
3	NUT, M10 DIN6334/BN1933 LONG COUPLING	F81033-19	1
4	OVERRUN DEVICE, 2600KG KW 251S B100	085591	1
5	NUT, M10-8-B-HEX ZINC	F81033-3	1
6	BRACKET, DRAWBAR FOR LT15 WIDE TRAILER	550498-1	1
7	BRACKET WELDMENT, DRAWBAR MOUNT	550488-1	1
8	WHEEL, JOCKEY	085862	1
9	WASHER, 17 FLAT ZINC	F81058-1	2
10	BOLT, M16X140-8.8 HEX HEAD ZINC	F81006-4	1
11	NUT, M16-8 HEX NYLON ZINC LOCK	F81036-2	1
12	WASHER, 10.5 FLAT ZINC	F81055-1	34
13	WASHER, Z 10.2 SPLIT LOCK ZINC	F81055-2	8
14	NUT, M10-8-B-HEX ZINC	F81033-3	12
15	BOLT, M10X70 8.8 HEX HEAD FULL THREAD ZI	F81003-20	8

PARTS LIST**1***Drawbar with Overrun Device, Trailer for LT15 Wide*

REF.	DESCRIPTION (* indicates parts available in assemblies only)	PART #	QTY	
16	WASHER,13 FLAT ZINC	F81056-1	4	
17	NUT, M12 8 HEX NYLON ZINC LOCK	F81034-2	2	
18	BOLT, M12X55-8.8 HEX HEAD ZINC	F81004-12	2	
19	NUT, M10-8-B HEX NYLON ZINC LOCK	F81033-1	9	
20	BOLT, DIN933-M10X30-8.8-A2E HEX HEAD	F81003-111	4	
21	BOLT, M10X75-8.8-HEX HEAD ZINC	F81003-15	5	
22	BRACKET, BRAKE ROD	538830-1	1	
23	ROD, BRAKE M10 L-1580MM	550613-1	2	
24	NUT, M10 DIN6334/BN1933 LONG COUPLING	F81033-19	2	

1 PARTS LIST

Additional Equipment, Trailer for LT15 Wide

1.32 Additional Equipment, Trailer for LT15 Wide

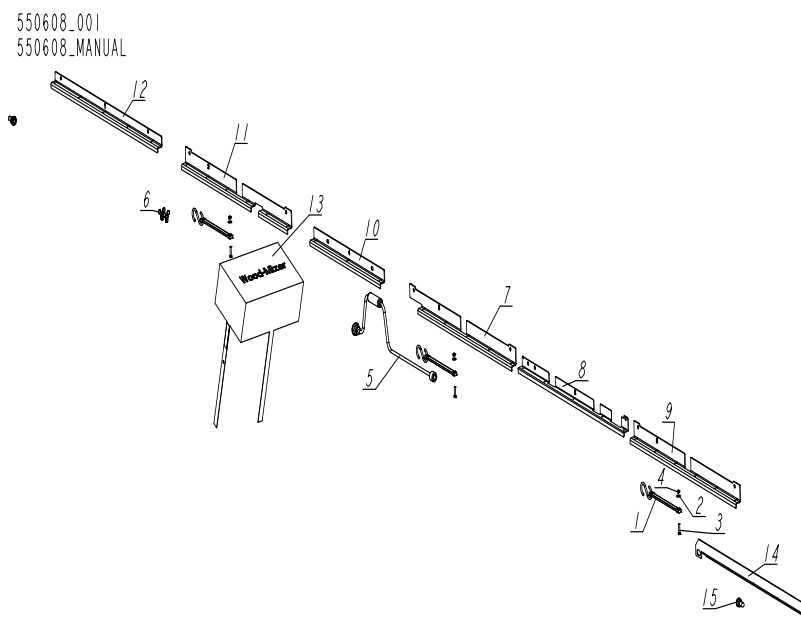

REF.	DESCRIPTION (* indicates parts available in assemblies only)	PART #	QTY
-	ADDITIONAL EQUIPMENT SET, TRAILER FOR LT15 WIDE	550608	1
1	STRAP, 9" RUBBER WITH HOOKS	012965	3
2	WASHER, 6.5 SPECIAL FLAT ZINC	F81053-11	3
3	BOLT, M6X30-8.8 HEX HEAD FULL THREAD ZIN	F81001-8	3
4	NUT, M6-8-B NYLON HEX ZINC LOCK	F81031-2	3
5	HANDLE, HKB SW 19-L660 (W 4460) CRANK -	084536	1
6	SCREW, M8-1.25X16 WING	F05021-32	2
7	DUCT, CABLE (3)	550610-1	1
8	PLATE	538792-1	1
9	DUCT, CABLE (6)	550611-1	1
10	DUCT, CABLE (4)	543904-1	1
11	DUCT, CABLE (2)	550609-1	1
12	PLATE	538923-1	1
13	COVER, 35X25X15 CONTROL BOX	550414	1
14	DUCT, CABLE	550809-1	1
15	M12 BOLT ELONGATED CAP	550829	2

1.33 Log Ramp w/Winch, LT15 Wide

550562_001
550562_MANUAL

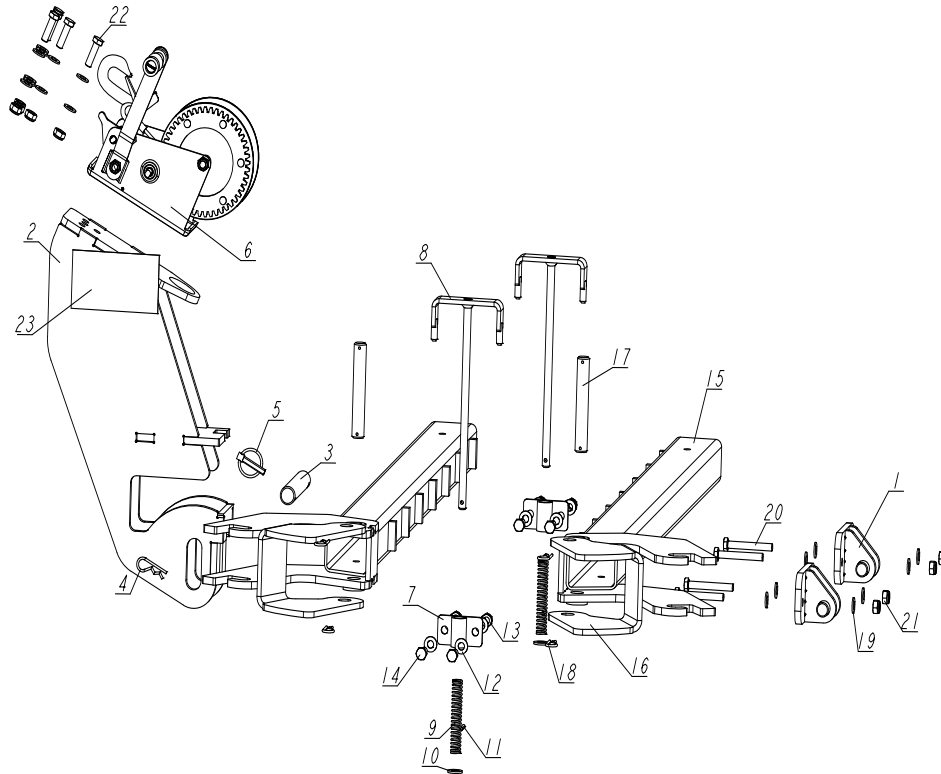

REF.	DESCRIPTION (◆ indicates parts available in assemblies only)	PART #	QTY
-	LOG RAMP W/WINCH, TRAILER FOR LT15 WIDE	550562	1
1	BRACKET, RAMP MOUNT	550550-1	2
2	MOUNT WELDMENT, WINCH	550626-1	1
3	PIN, LOCK	534657-1	1
4	PIN, 1/8X1 13/16 SAFETY	P05059	1
5	PIN, 8 BN914 (BOSSARD 134650) LOCK	F81046-2	1
6	WINCH, DWK 35V HAND	534651	1
-	MOUNT, LOG RAMP	538787	2
7	MOUNT WELDMENT	538786-1	1
8	HANDLE	538784-1	1
9	SPRING 13X100X2.0	538788	1
10	WASHER,13 FLAT ZINC	F81056-1	1
11	PIN, 5X26 ROLL ZINC	F81044-2	1
12	WASHER OKR. 10,5 FE/ZN5 PN-78/M-82005	F81055-1	4
13	NUT, M10-8-B HEX NYLON ZINC LOCK	F81033-1	2
14	BOLT, M10X30-5.8 HEX HEAD FULL THREAD ZI	F81003-2	2
-	LEG, LOG RAMP - COMPLETE	550563	2
15	LEG WELDMENT, LOG RAMP	550553-1	1

1**PARTS LIST***Log Ramp w/Winch, LT15 Wide*

REF.	DESCRIPTION (◆ indicates parts available in assemblies only)	PART #	QTY	
16	PLATE	550559-1	1	
17	PIN, LOCK	550561-1	1	
18	PIN, 1/8X1 13/16 SAFETY	P05059	2	
19	WASHER OKR. 10,5 FE/ZN5 PN-78/M-82005	F81055-1	18	
20	BOLT, M10X75-8.8-HEX HEAD ZINC	F81003-15	4	
21	NUT, M10-8-B HEX NYLON ZINC LOCK	F81033-1	9	
22	BOLT, M10X35-8.8 HEX HEAD FULL THREAD ZI	F81003-17	5	
23	DECAL, WINCH - TRAILER FOR LT15 WIDE	550824	1	

1.34 Blade Height Scale, LT15 Wide (mobile sawmills)

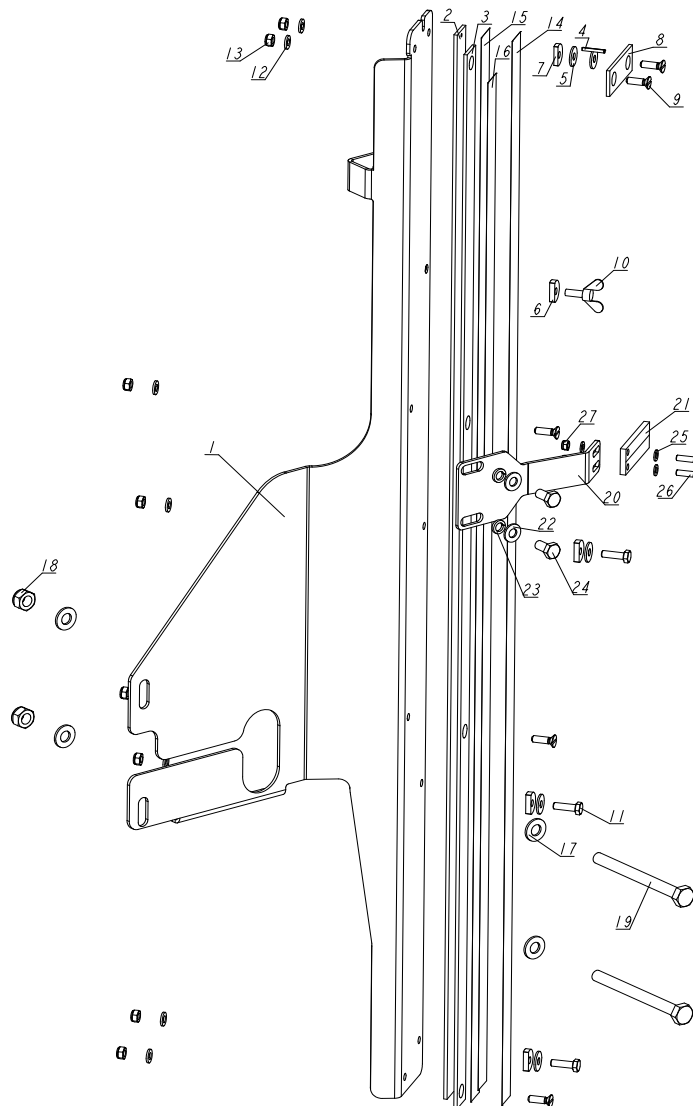
538613-001_A
538613_MANUAL

REF.	DESCRIPTION (◆ indicates parts available in assemblies only)	PART #	QTY
-	BLADE HEIGHT SCALE ASSEMBLY, LT15 WIDE	538613	1
-	BASE, BLADE HEIGHT SCALE, LT15 WIDE - COMPLETE	550437	1
1	BRACKET WELDMENT, BLADE HEIGHT SCALE	550436-1	1
2	BAR, SCALE	550434	1
3	BAR, SCALE	550435	1
4	PIN, 3X20 ROLL ZINC	F81044-5	1
5	WASHER, 6.5 SPECIAL FLAT ZINC	F81053-11	5
6	WASHER, 6.2X20X4.5 SPECIAL	503098	4
7	WASHER, 6.2X20X3.5 SPECIAL	503096	1
8	BAR, SCALE MOUNT	093134	1

1

PARTS LIST

Blade Height Scale, LT15 Wide (mobile sawmills)

REF.	DESCRIPTION (◆ indicates parts available in assemblies only)	PART #	QTY	
9	SCREW, M6X20-5.8-B SLOTTED COUNTERSUNK H	F81001-31	5	
10	SCREW, M6 X 16 BN276 DIN 316 THUMB	F81001-16	1	
11	BOLT, M6X20 8.8 HEX HEAD FULL THREAD ZIN	F81001-2	3	
12	WASHER, 6.4 FLAT ZINC	F81053-1	8	
13	NUT, M6-8-B HEX NYLON ZINC LOCK	F81031-2	8	
14	DECAL, METRIC SCALE 16-40MM, LT15 WIDE	550438	1	
15	DECAL, METRIC SCALE, 45-63MM, LT15 WIDE	550439	1	
16	DECAL, CENTIMETER-SCALE, LT15 WIDE	550440	1	
17	WASHER, 10.5 FLAT ZINC	F81055-1	4	
18	NUT, M10-8-B HEX NYLON ZINC LOCK	F81033-1	2	
19	BOLT, M10 X 115-8.8 FE/ZN5, PN-M/82101	F81003-19	2	
-	BLADE HEIGHT SCALE INDICATOR - COMPLETE	550801	1	
20	PLATE, BLADE HEIGHT SCALE	550797-1	1	
21	INDICATOR, BLADE HEIGHT SCALE	094821	1	
22	WASHER, 8.4 FLAT ZINC	F81054-1	2	
23	WASHER 8,2 SPLIT LOCK ZINC	F81054-4	2	
24	BOLT, M8X16 -8.8-B HEX HEAD FULL THREAD	F81002-20	2	
25	WASHER, 5.3 FLAT ZINC	F81052-1	4	
26	BOLT, M5X16-8.8 HEX HEAD FULL THREAD ZIN	F81000-20	2	
27	NUT, M5-8 DIN985 ZINC-PLATED	F81030-2	2	