

FORM 135PL INSTRUCTIONS FOR MOUNTING POWER FEED SYSTEM ON LT15AC SAWMILLS REV.F1.00

 **WARNING!** Before performing any service to the sawmill control box panel, turn the key to the “0”. Set the main switch, located on the control box in “0” position and disconnect the power supply cable.

To mount the power feed system (Part No. **500860**) on LT15AC Rev. F1.00 sawmills with manual feed system manufactured from 28 September 2009 it is necessary to:

1. Remove the lower guard.

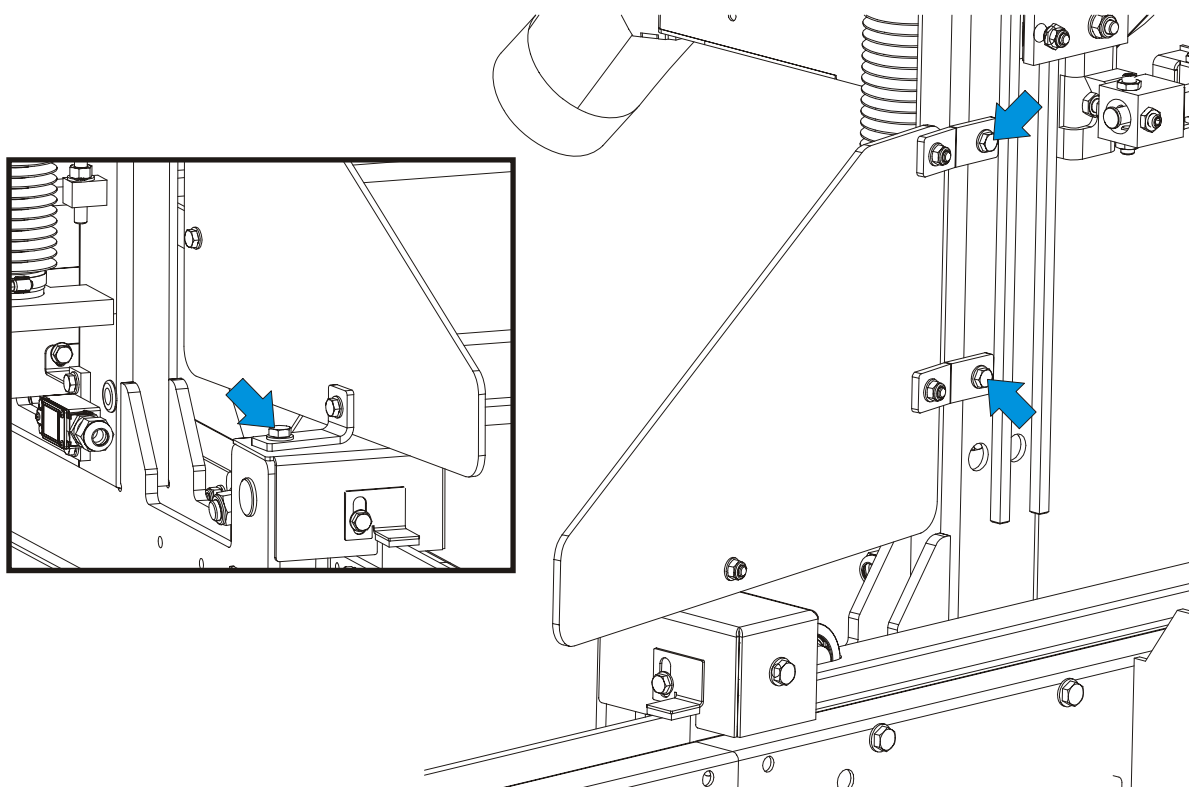

2. Remove middle track cover with felt strip.

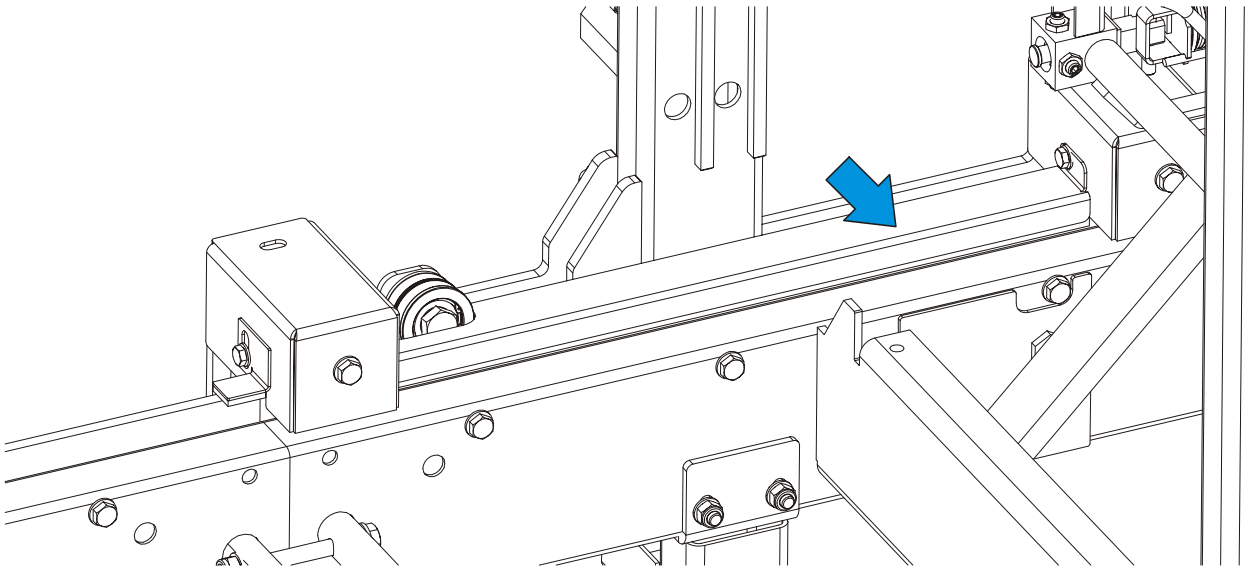

3. Take the rope off and remove front & rear rope mount brackets.

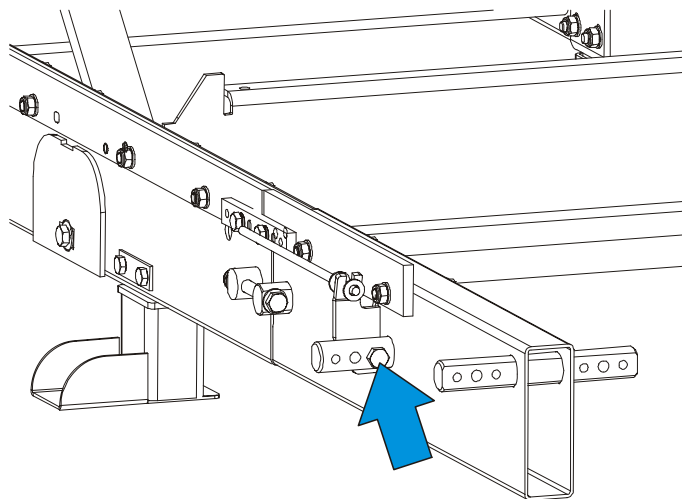
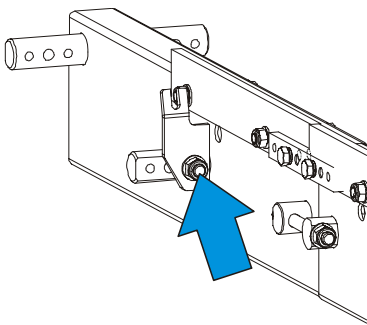

4. Remove feed crank and manual feed system support.

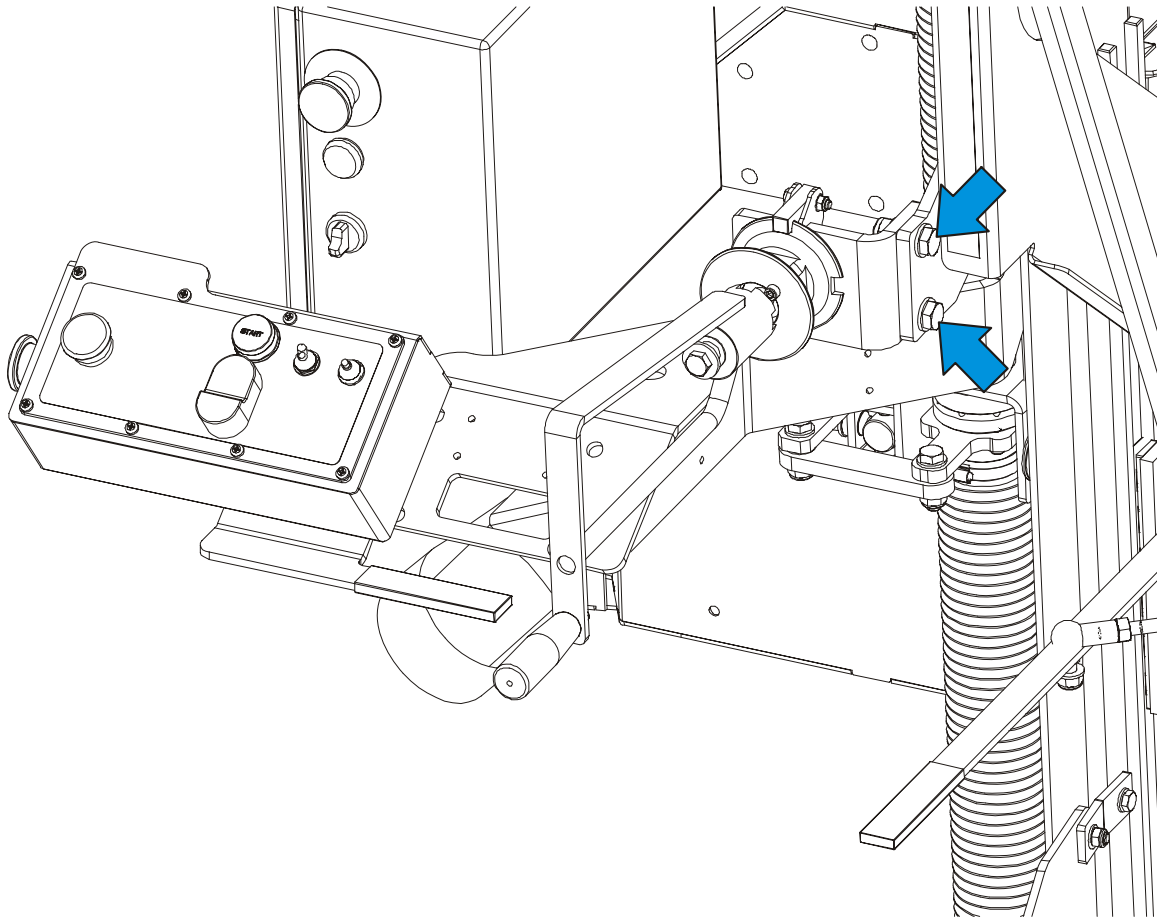

5. Remove the rope guide roller system.

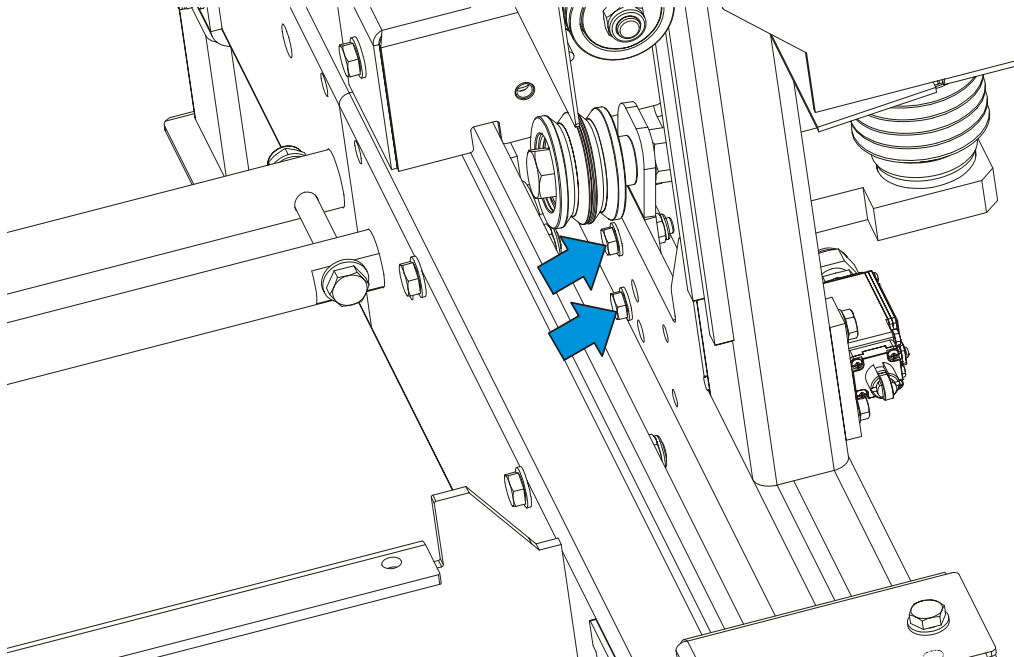

6. Dismount control box front panel. Mount forward/backward joystick and feed speed potentiometer. Make electrical connections according to electrical diagram attached at the end of instruction.

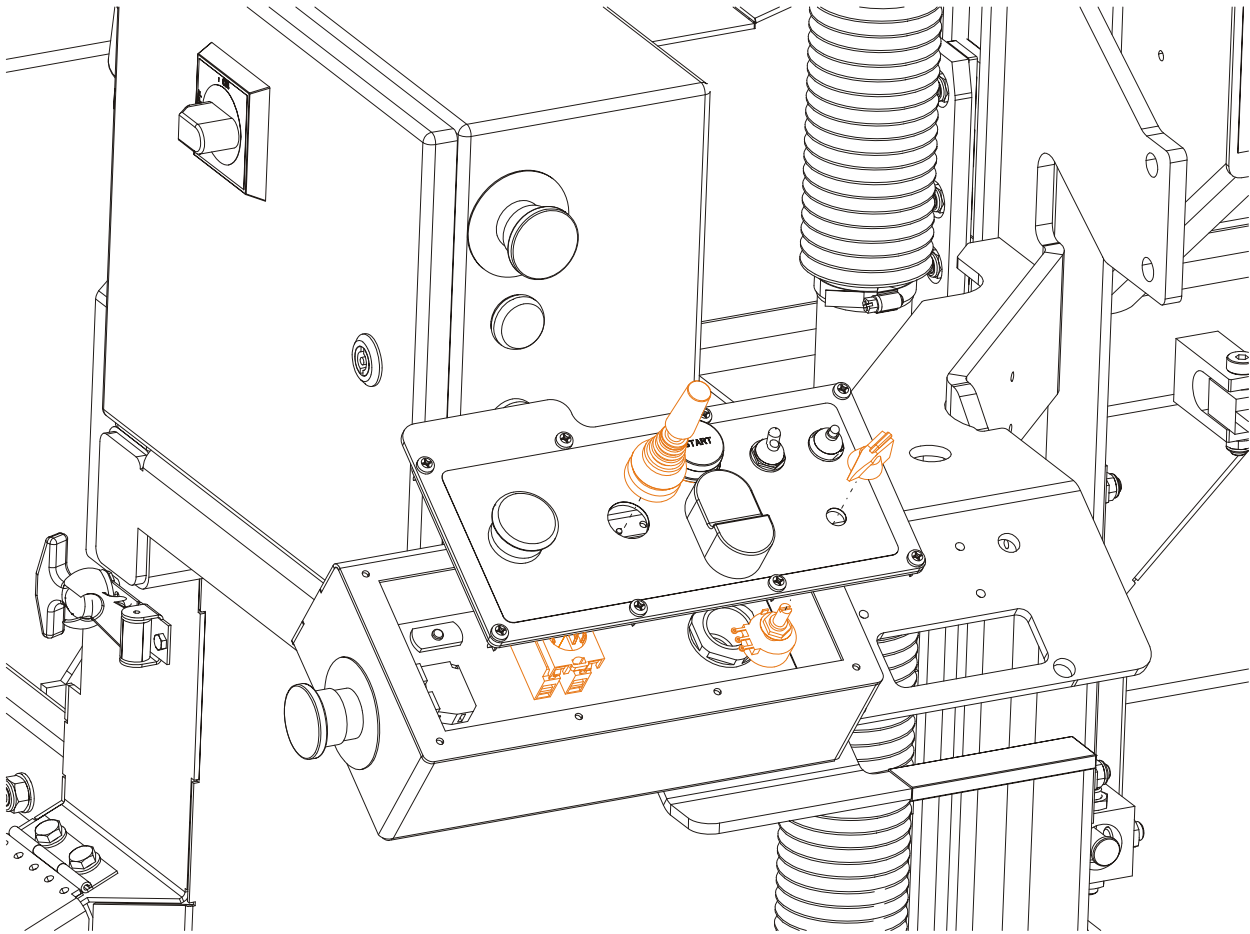

7. Mount power feed support plates with rubber bushings (2) to pins placed in the middle of bed extensions (1), screw tensioners (3) to extreme pins. Fasten spring to short tensioner.

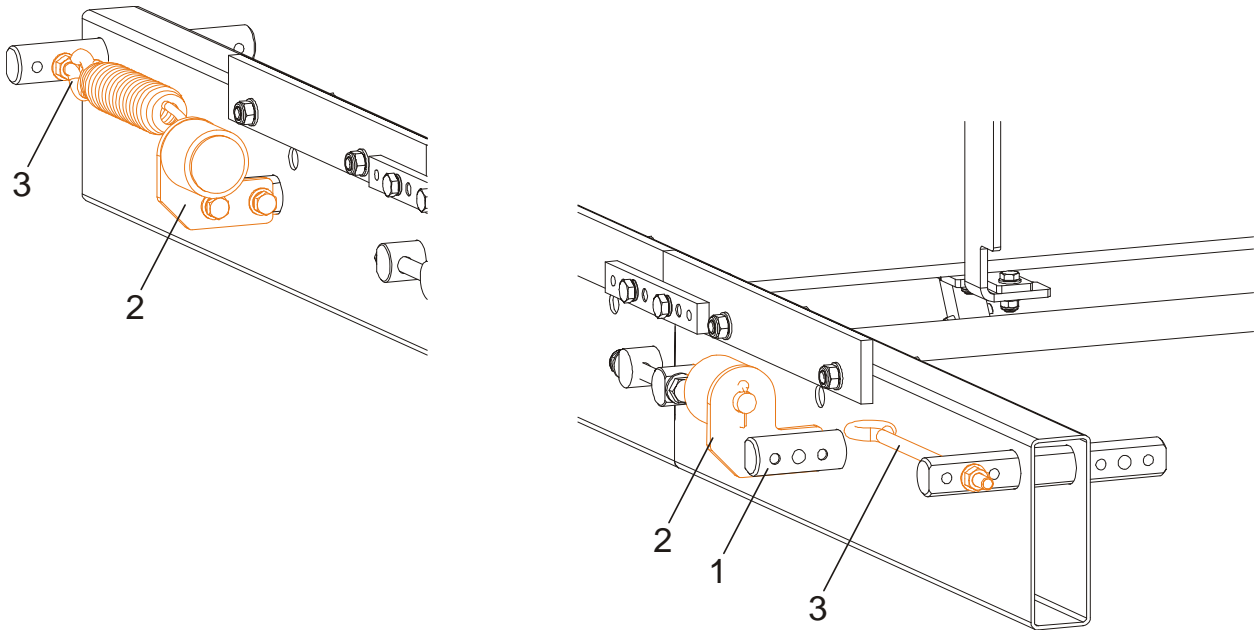

8. Mount the motoreducer with four bolts.

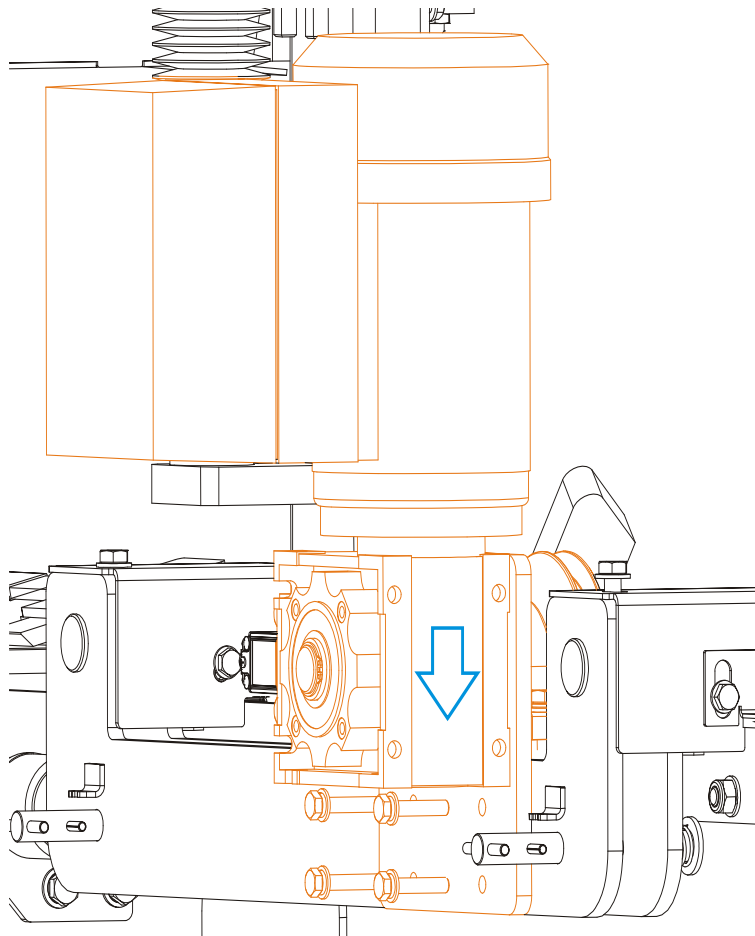

9. Prepare cable by closing its ends up using steel links.

10. Mount the cable. Install it on pulley as shown below and protect by clamps (1). Tighten the rope, until the gap between spring coils will be 0,8-1,2mm.

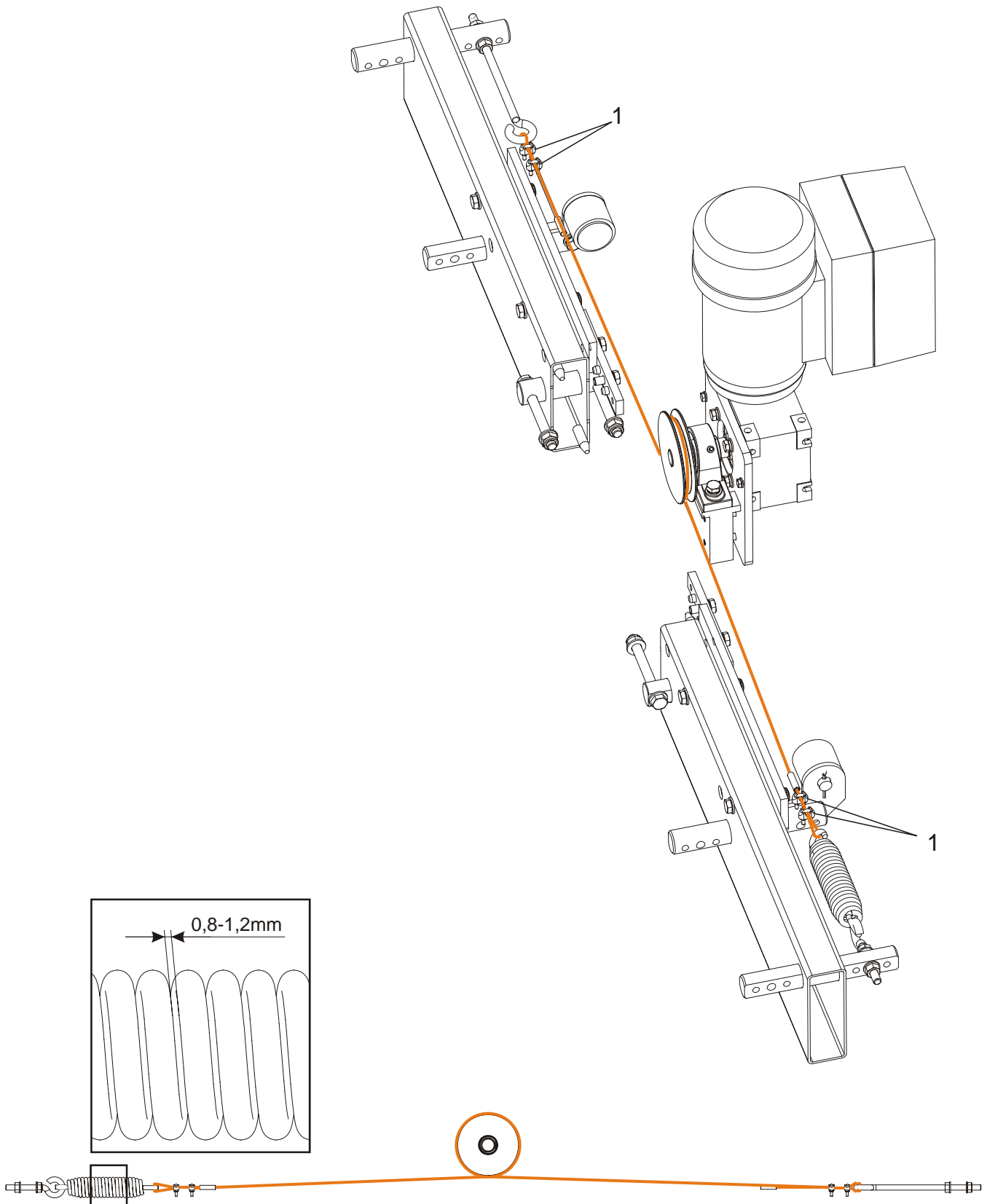

11. Mount new middle track cover with felt strip. Soak up the felt strip by oil (WD-40).

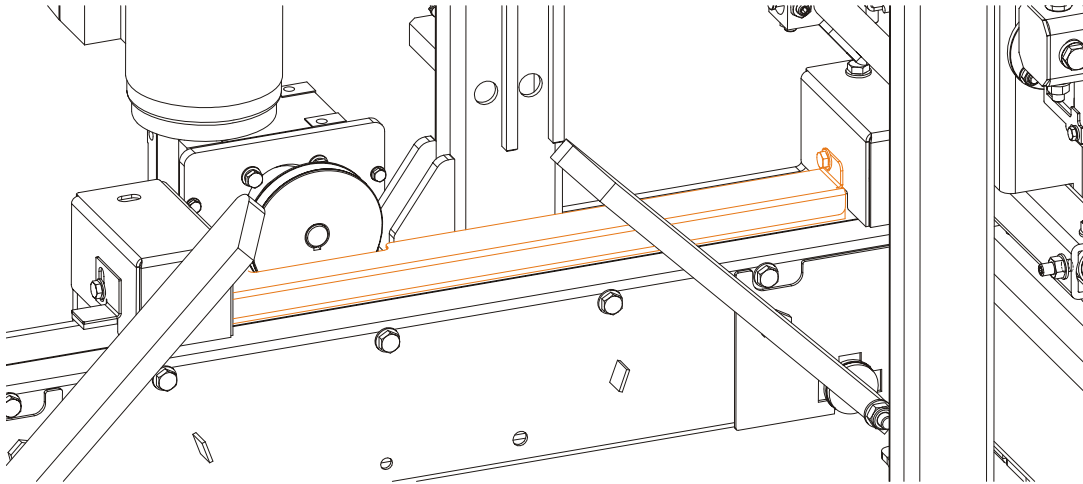

12. Mount a motoreducer pulley front cover.

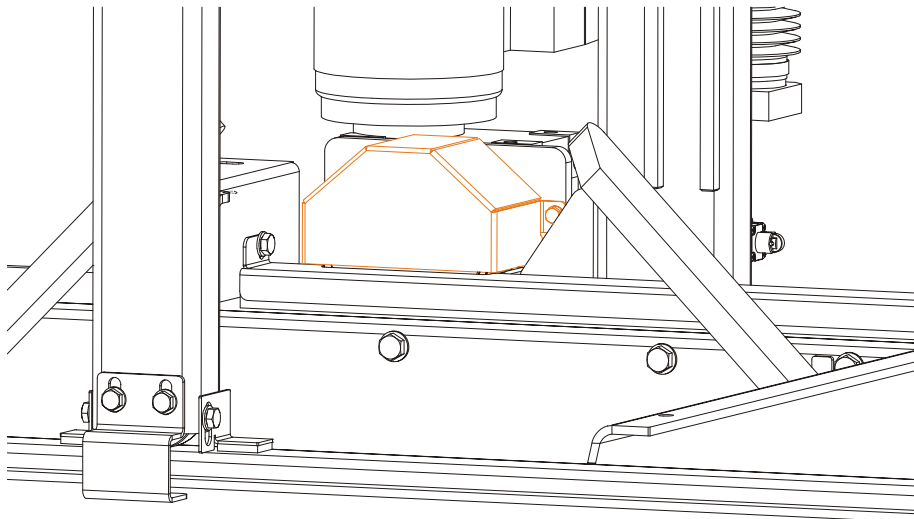

13. Mount new lower guard.

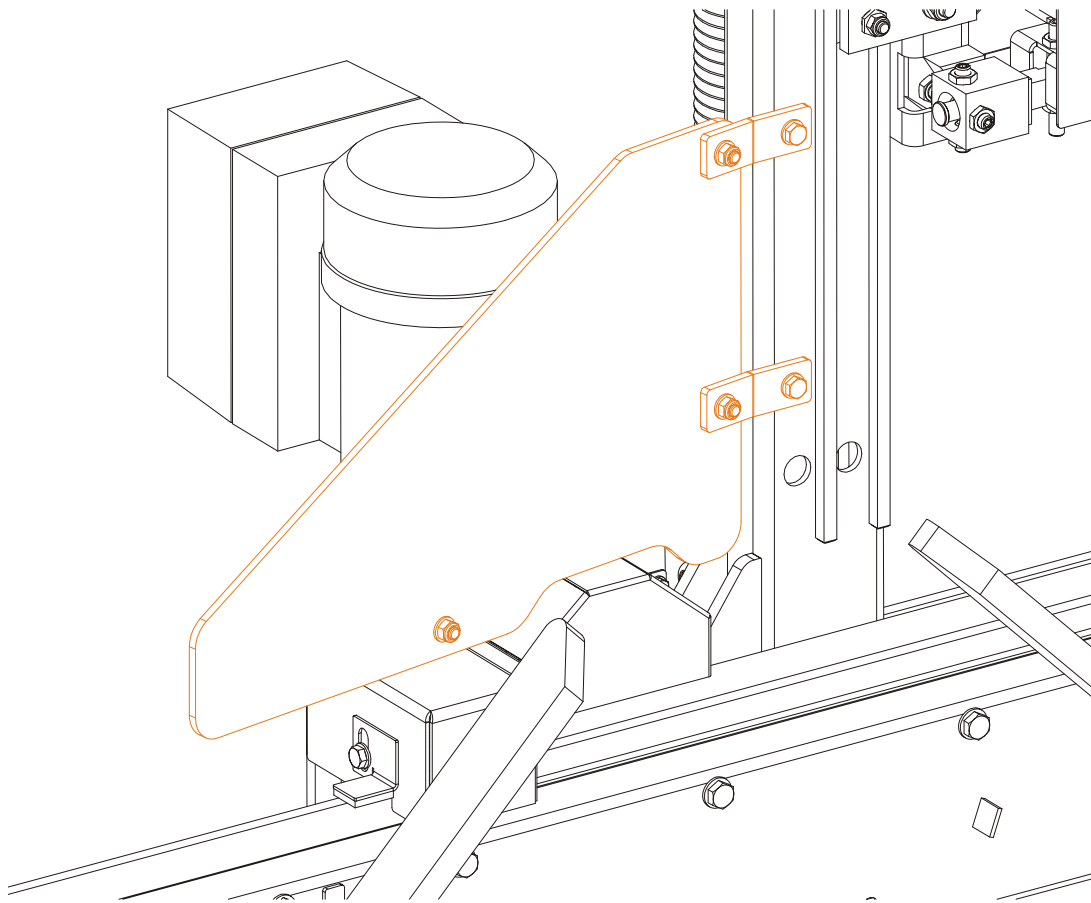

LT15AC Electrical Diagram with Power Feed System

