

# **Wood-Mizer®**

## **Replacement Parts**

---

**MP160 E3S**

**rev. A1.02**

**MP160 E3S-V**

**rev. A1.02**

---



**Safety is our #1 concern!** Read and understand all safety information and instructions before operating, setting up or maintaining this machine.

*Form #2403*

# Table of Contents

# Section-Page

<b>SECTION 1</b>	<b>GENERAL INFORMATION</b>	<b>1-1</b>
1.1	How To Use the Parts List.....	1-1
1.2	Sample Assembly .....	1-1
<b>SECTION 2</b>	<b>PLANER/THICKNESSER, MP160</b>	<b>2-1</b>
2.1	Shaft .....	2-1
2.2	Side covers .....	2-2
2.3	Inspection Window Covers .....	2-3
2.4	Chain slide block .....	2-4
2.5	Chip duct .....	2-5
2.6	Knife Set .....	2-6
2.7	Decals .....	2-7
2.8	MP160 Table Extension (Part No. 540581) .....	2-9
2.9	Castor wheels 535166 .....	2-10
2.10	Castor wheel assembly 535163 .....	2-11
2.11	Wrench Set (No. 535185) .....	2-12
2.12	Foot Set (No. 536996) .....	2-13
2.13	Protective guard adjustment assembly 534170 .....	2-14
2.14	Bottom table (No. 534352) .....	2-15
2.15	Chip channel assembly 534218 .....	2-16
2.16	Small guard assembly 534182 .....	2-17
2.17	Chain tensioner assembly 534171 .....	2-18
2.18	Pusher 534166 .....	2-19
2.19	Cutter protective cover assembly 534752 .....	2-20
2.20	Cutter assembly 534223 .....	2-21
2.21	Cutter assembly 534785 .....	2-23
2.22	Helical Top Cutter assembly THH160TC-S .....	2-25
2.23	Cutter Guard (No. 534220) .....	2-26
2.24	Bearing assembly 534225 .....	2-27
2.25	Upper outfeed table 534205 .....	2-28
2.26	Mounting bar assembly 534357 .....	2-29
2.27	Fence assembly 534185 .....	2-30
2.28	Adjuster Assembly, Fence Panel (No. 534213) .....	2-32
2.29	Upper infeed table 534355 .....	2-33
2.30	Front guide rail assembly 534375 .....	2-34
2.31	Rear guide rail assembly 534376 .....	2-35
2.32	Infeed table adjustment handle 534380 .....	2-36
2.33	Up/down Assembly 534385 .....	2-37
2.34	Chain Tensioner (No. 534390) .....	2-39
2.35	Knob and scale assembly 534760 .....	2-40
<b>SECTION 3</b>	<b>MOTOR KITS, 534198, 534197</b>	<b>3-1</b>
3.1	MP160 Motor Kits PRO 534198, ECO 534197 .....	3-1

## Table of Contents

## Section-Page

3.2	Cutting Head Drive 534196 .....	3-3
3.3	ECO Feed drive 533638 .....	3-5
3.4	PRO Feed drive 533650 .....	3-6
3.5	Electric box 532805 .....	3-8
3.6	Cover MP160 534776 .....	3-9
3.7	Cover MP160 UL 570009 .....	3-11
3.8	Emergency stop switch assembly 535669 .....	3-12

## SECTION 1 GENERAL INFORMATION

### 1.1 How To Use the Parts List

- Use the index above to locate the assembly that contains the part you need.
- Go to the appropriate section and locate the part in the illustration.
- Use the number pointing to the part to locate the correct part number and description in the table.
- Parts shown indented under another part are included with that part.
- Parts marked with a diamond (◆) are only available in the assembly listed above the part.

See the sample table below. Sample Part #A01111 includes part F02222-2 and subassembly A03333. Subassembly A03333 includes part S04444-4 and subassembly K05555. The diamond (◆) indicates that S04444-4 is not available except in subassembly A03333. Subassembly K05555 includes parts M06666 and F07777-77. The diamond (◆) indicates M06666 is not available except in subassembly K05555.

1.2 Sample Assembly				
REF.	DESCRIPTION (◆ Indicates Parts Available In Assemblies Only)	PART #	QTY	
	Sample Assembly, Complete (Includes All Indented Parts Below)	A01111	1	
1	Sample Part	F02222-22	1	
	Sample Subassembly (Includes All Indented Parts Below)	A03333	1	
2	Sample Part (◆ Indicates Part Is Only Available With A03333)	S04444-4	1	◆
	Sample Subassembly (Includes All Indented Parts Below)	K05555	1	
3	Sample Part (◆ Indicates Part Is Only Available With K05555)	M06666	2	◆
4	Sample Part	F07777-77	1	

#### To Order Parts:

- From Europe call our European Headquarters and Manufacturing Facility in Kolo, Poland at **+48-63-2626000**. From the continental U.S., call our toll-free Parts hotline at **1-800-525-8100**. Have your customer number, vehicle identification number, and part numbers ready when you call. From other international locations, contact the Wood-Mizer distributor in your area for parts.

#### Office Hours:

Country	Monday - Friday	Saturday	Sunday
Poland	7-15	Closed	Closed
US	8 a.m.- 5 p.m.	8 a.m.- 12 p.m.	Closed



**CAUTION!** It is strongly recommended that only original spare parts be used.

## SECTION 2 PLANER/THICKNESSER, MP160

### 2.1 Shaft

MP160EH3S-V\_002  
MP160EH3S-V\_MANUAL

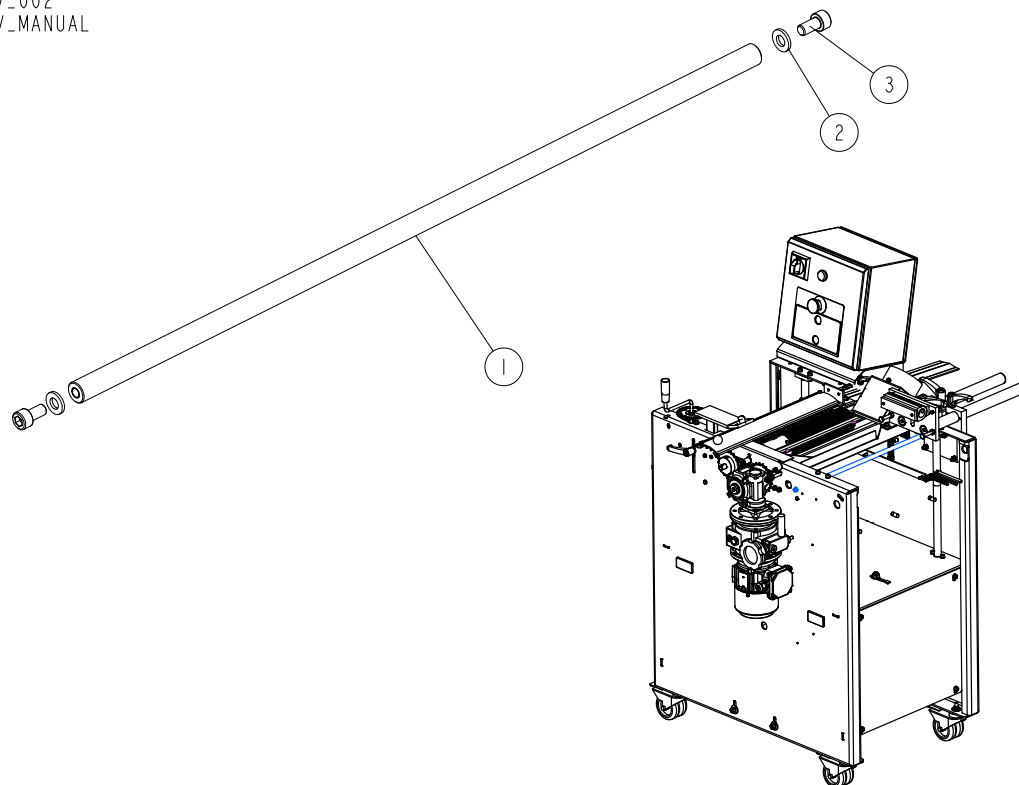

REF.	DESCRIPTION (* indicates parts available in assemblies only)	PART #	QTY
1	SHAFT	533092-1	1
2	WASHER, 6.4 FLAT ZINC	F81053-1	2
3	SCREW, ISO 4762-M6X12-8.8-A2E HEX SOCKET HEAD CAP	F81001-87	2

2.2 Side covers

MP160EH3S-V\_003-1  
MP160EH3S-V\_MANUAL

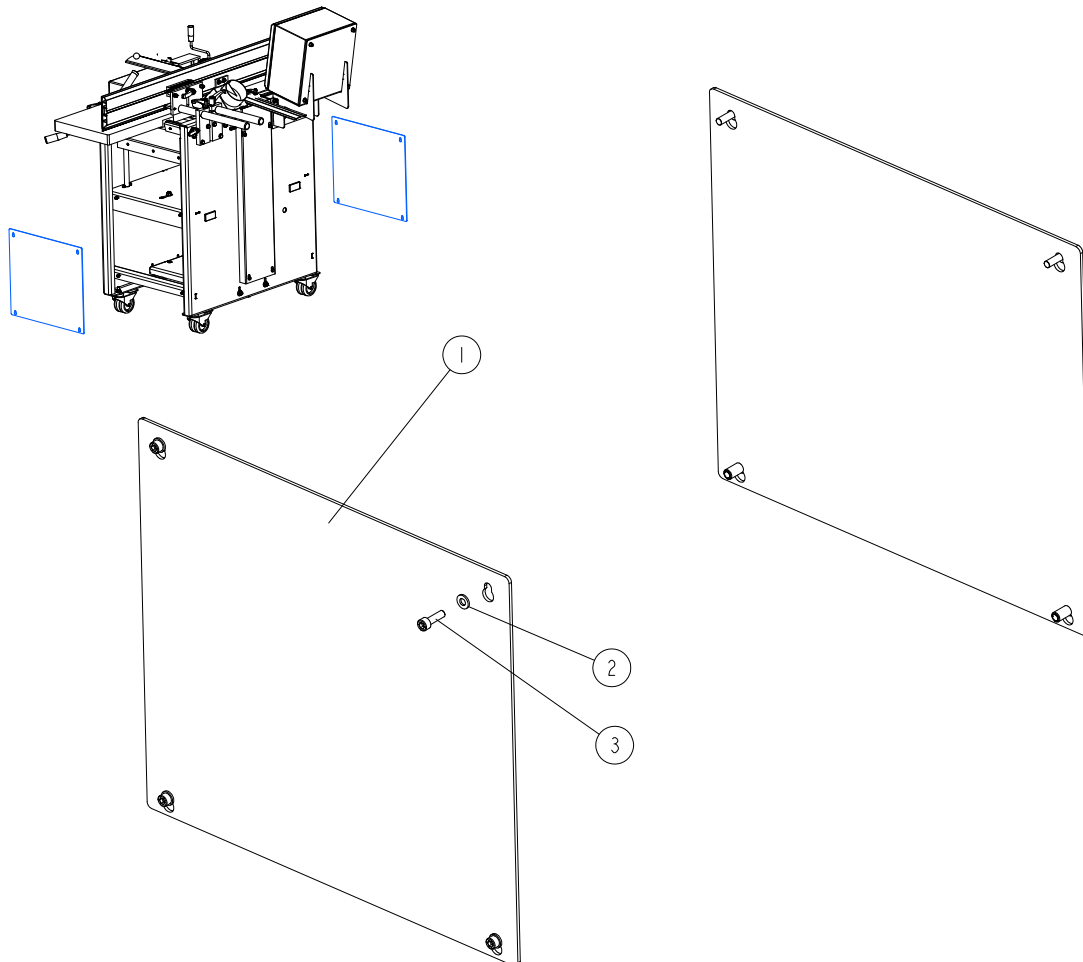

REF.	DESCRIPTION (* indicates parts available in assemblies only)	PART #	QTY
1	PLATE, SIDE	533096-1	2
2	WASHER, 6.4 FLAT ZINC	F81053-1	8
3	SCREW, M6X20 8.8 HEX SOCKET HEAD CAP ZINC	F81001-22	8

**2.3 Inspection Window Covers**

MP160EH3S-V\_009  
 MP160EH3S-V\_MANUAL

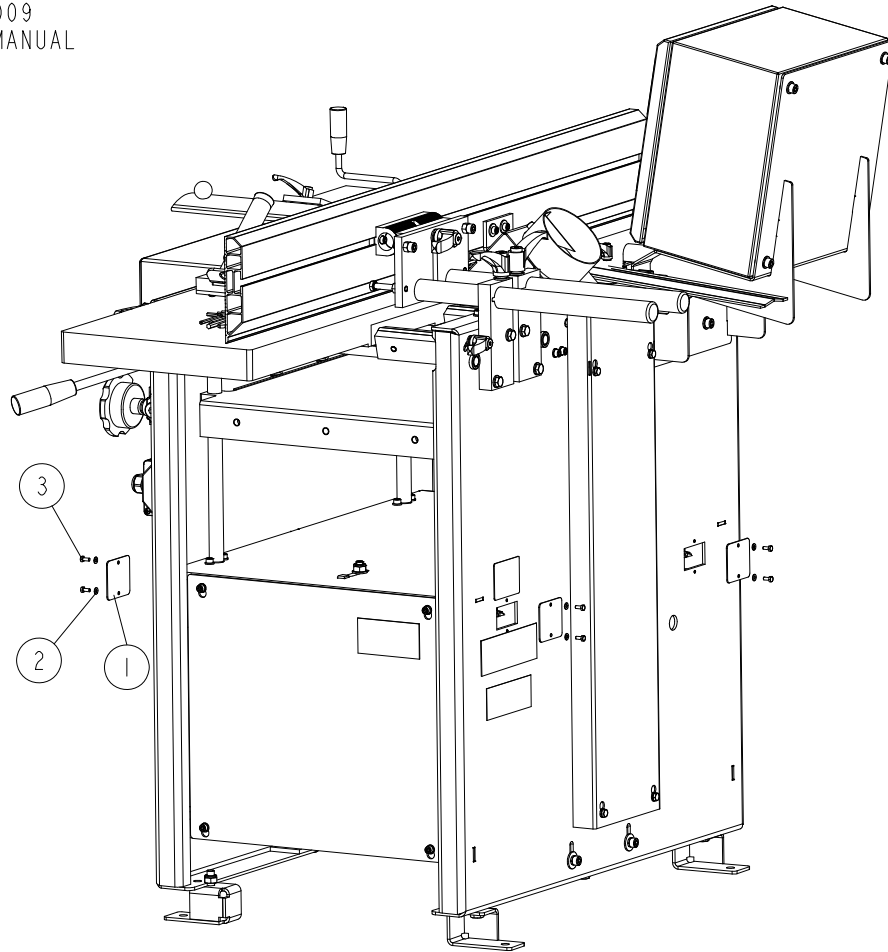

REF.	DESCRIPTION (* indicates parts available in assemblies only)	PART #	QTY
-	<b>MP160EH3S-V PLANER/THICKNESSER</b>	MP160EH3S-V	1
1	COVER, INSPECTION WINDOW	536995-1	4
2	WASHER, 4.3 FLAT ZINC	F81051-2	8
3	BOLT, M4X10 DIN933(A2)/ISO 4017 STAINLESS STEEL	F81000-27	8

2.4 Chain slide block

MP160EH3S-V\_006-1  
MP160EH3S-V\_MANUAL

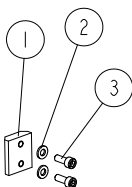

SCALE 0.140

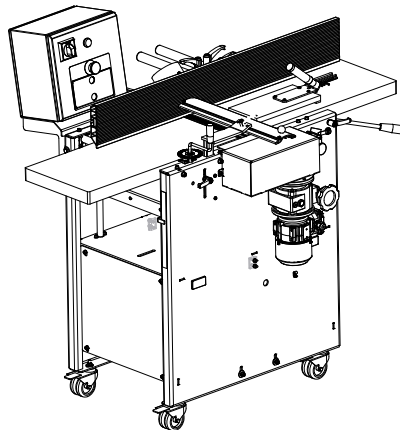

REF.	DESCRIPTION (* indicates parts available in assemblies only)	PART #	QTY
1	BLOCK, CHAIN SLIDE	533681	2
2	WASHER, 6.4 FLAT ZINC	F81053-1	4
3	SCREW, M6X16 8.8 HEX SOCKET HEAD CAP ZINC	F81001-21	4



## 2.5 Chip duct

534180\_001  
 534180\_MANUAL

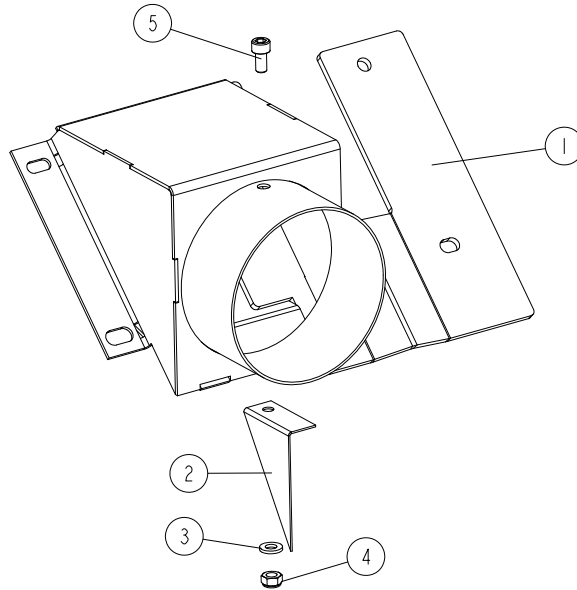

REF.	DESCRIPTION (* indicates parts available in assemblies only)	PART #	QTY
-	<b>DUCT, CHIP</b>	534180	1
1	DUCT, CHIP	534175-1	1
2	PLATE, CHIP DUCT	534179	1
3	WASHER, 6.4 FLAT ZINC	F81053-1	1
4	NUT, M6-8-B HEX NYLON ZINC LOCK	F81031-2	1
5	SCREW, ISO 4762-M6X12-8.8-A2E HEX SOCKET HEAD CAP	F81001-87	1

**2.6 Knife Set**

MP160EH3S-V\_010  
MP160EH3S-V\_MANUAL

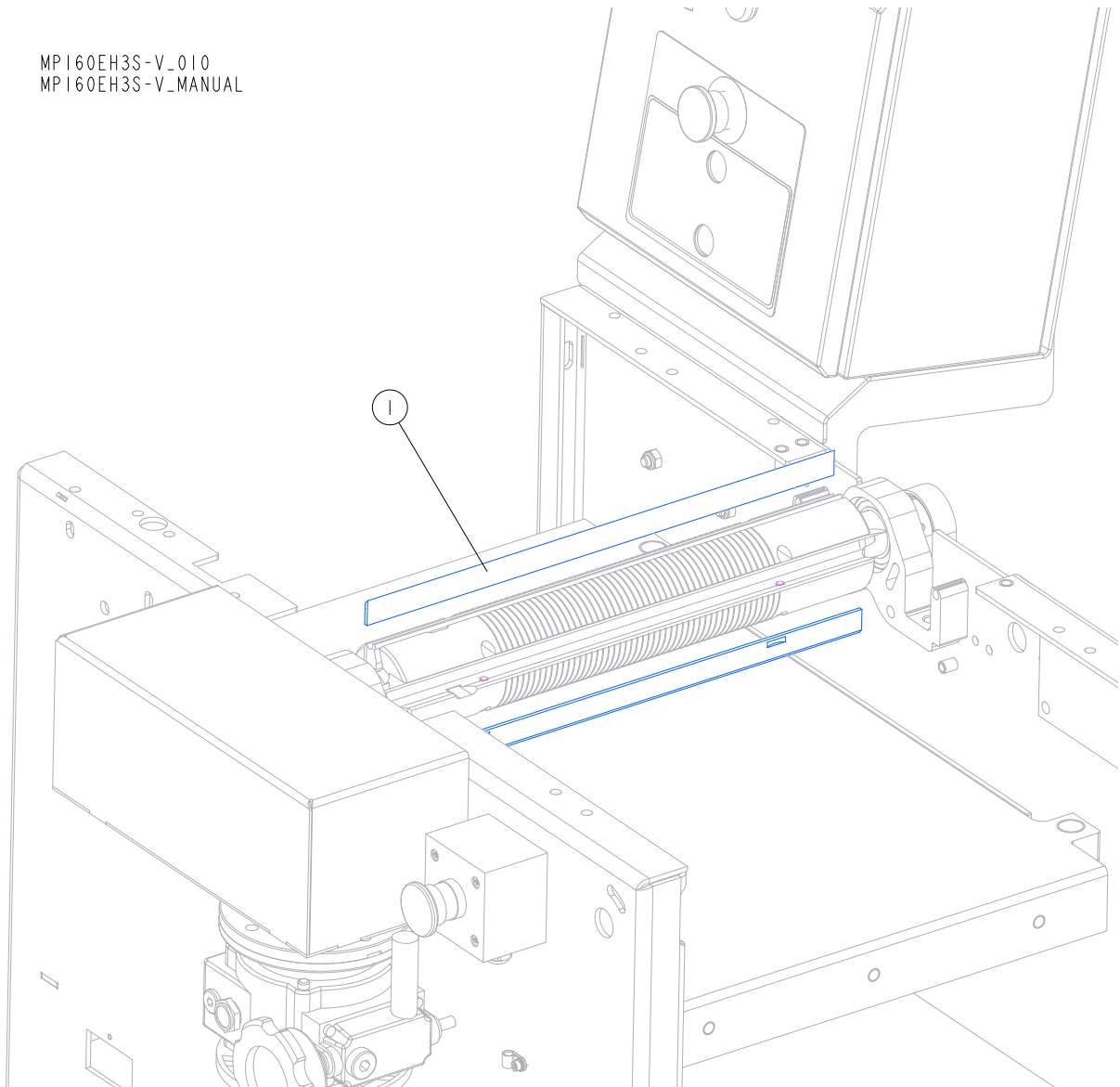

REF	DESCRIPTION (* indicates parts available in assemblies only)	PART #	QTY
1	PLANER KNIFE WITH NOTCHES	TPK410.20MP	2

2.7 Decals

MP160EH3S-V\_007  
MP160EH3S-V\_MANUAL

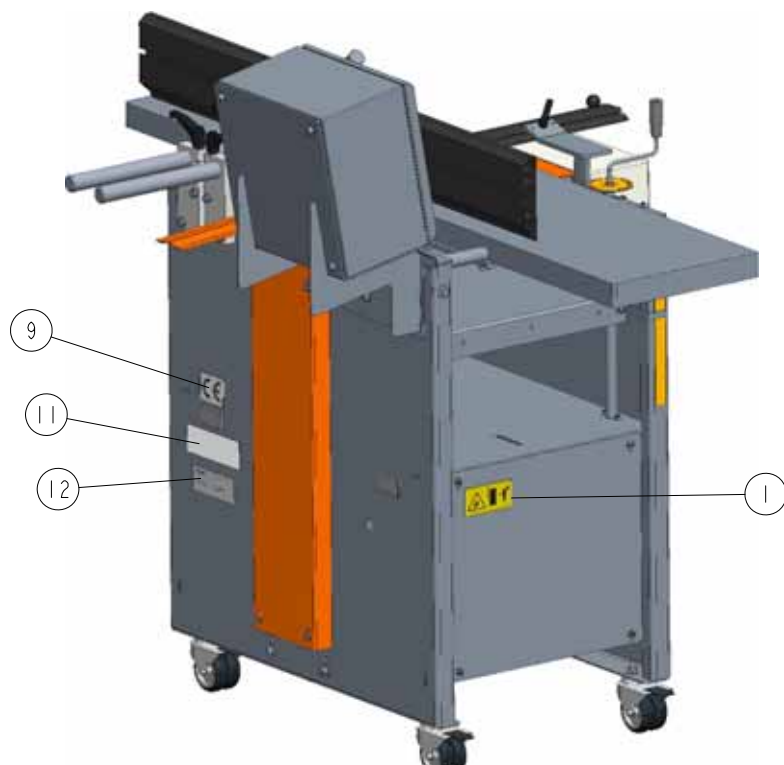
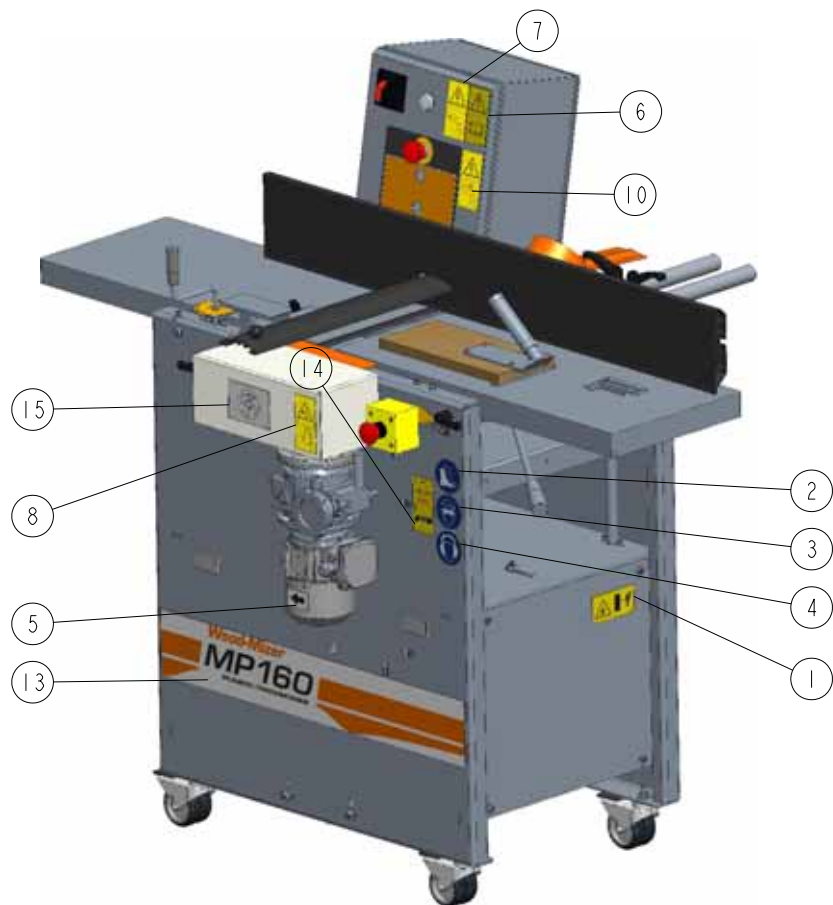

REF.	DESCRIPTION (* indicates parts available in assemblies only)	PART #	QTY
-	DECAL KIT, MP160	536229	1
1	DECAL, "KEEP A SAFE DISTANCE" PICTOGRAM	099221H	2
2	DECAL, "WEAR SAFETY BOOTS" PICTOGRAM, SMALL	501465-1	1
3	DECAL, "WEAR SAFETY GOGGLES" (PICTOGRAM) - SMALL	S12004G-1	1
4	DECAL, "WEAR PROTECTIVE EAR MUFFS" (PICTOGRAM) SMALL	S12005G-1	1
5	DECAL, MOTOR DIRECTION	S20097	1
6	DECAL, "READ THE OPERATOR'S MANUAL"	096317	1
7	DECAL, HAZARDOUS VOLTAGE INSIDE THE ELECTRIC BOX (PICTOGRAM)	096316	1
8	DECAL, "CLOSE GUARDS BEFORE OPERATING"	099220	1
9	DECAL, CE CERTIFIED SAWMILL - SMALL	P85070	1
10	DECAL, REMOVE THE PLUG BEFORE OPENING THE ELECTRIC BOX (PICTOGRAM)	096319	1
11	DECAL, VIN	VIN	1
12	DECAL, EUROPEAN HEADQUARTER ADDRESS	015841	1
13	DECAL, MP160 PLANER TYPE	536228	1
14	DECAL, "USE THE CONTINUOUSLY VARIABLE TRANSMISSION WHEN THE FEED IS TURNED ON" (PICTOGRAM)	535252	1
15	DECAL, MP160 SHAFT ROTATION DIRECTION	536401	1

## 2.8 MP160 Table Extension (Part No. 540581)

MP160EH3S-V\_011  
MP160EH3S-V\_MANUAL

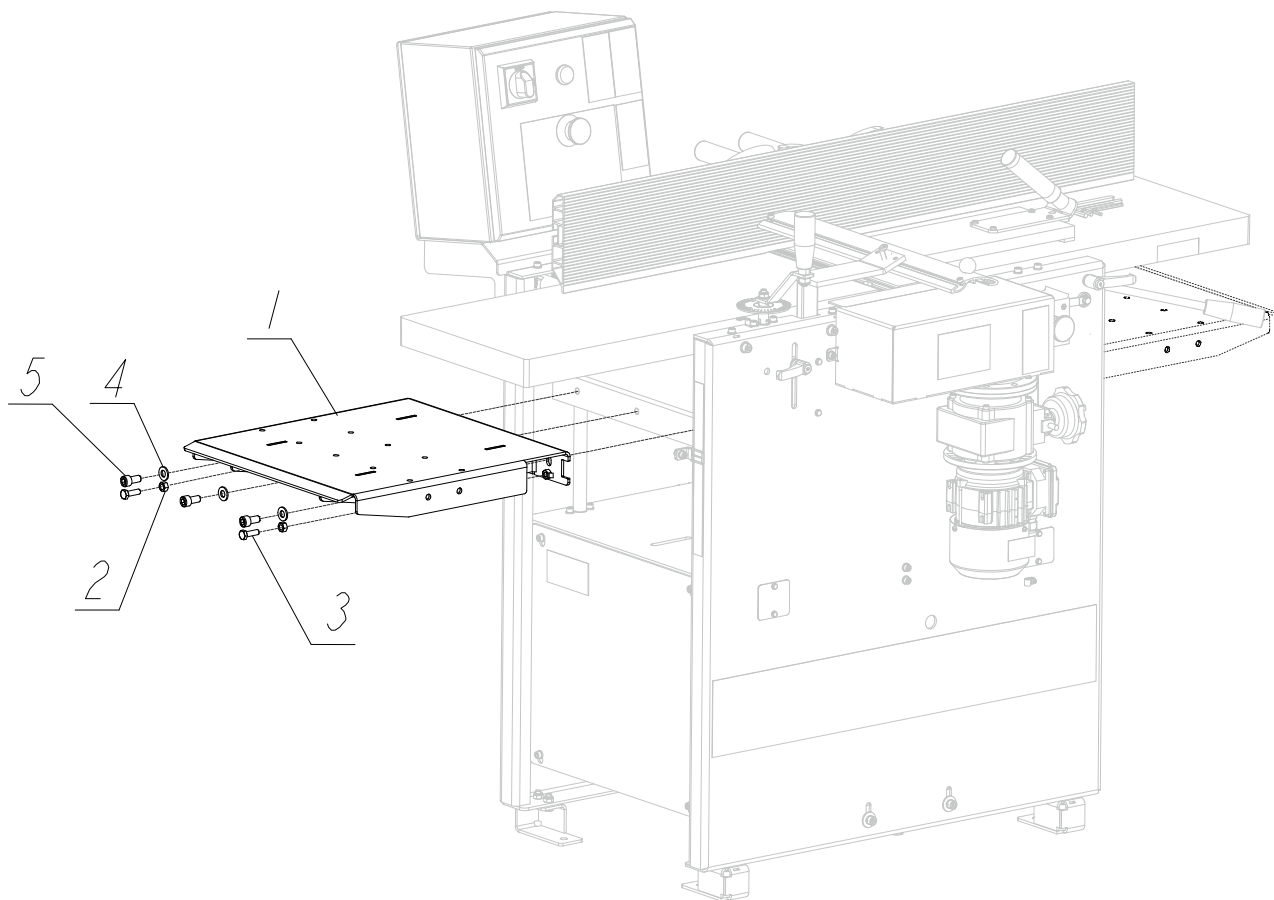

REF.	DESCRIPTION (* indicates parts available in assemblies only)	PART #	QTY	
-	<b>EXTENSION, MP160 TABLE - COMPLETE</b>	540581	2	
1	EXTENSION WELDMENT, MP160 TABLE	540580-1	1	
2	NUT, M8-8-B HEX ZINC	F81032-1	2	
3	BOLT, M8X25-8.8-B HEX HEAD FULL THREAD ZINC	F81002-5	2	
4	WASHER, 10.5 FLAT ZINC	F81055-1	3	
5	SCREW, M10X20 8.8 HEX SOCKET HEAD CAP ZINC	F81003-108	3	

## 2.9 Castor wheels 535166

535166\_001  
535166\_MANUAL

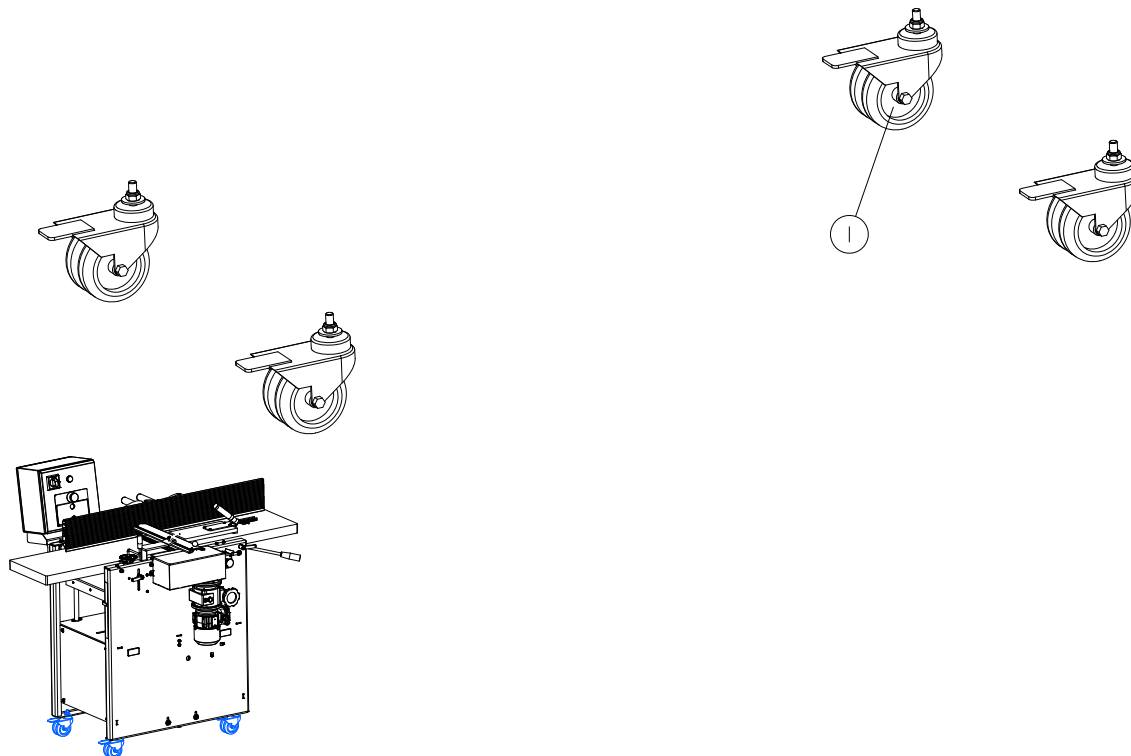

REF.	DESCRIPTION (* indicates parts available in assemblies only)	PART #	QTY	
-	CASTOR WHEELS, 4 PCS. KIT	535166	1	
1	CASTOR WHEEL ASSEMBLY <a href="#">See Section 2.10</a>	535163	4	

## 2.10 Castor wheel assembly 535163

535163\_001  
535163\_MANUAL

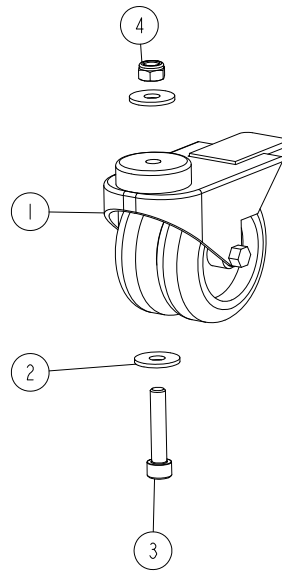

REF.	DESCRIPTION (* indicates parts available in assemblies only)	PART #	QTY	
-	<b>CASTOR WHEEL ASSEMBLY</b>	535163	1	
1	DUAL WHEEL CASTOR, KMDA-TPA 75S-HC	533510	1	
2	WASHER, ISO 7093-1-8-200 HV-A2E.	F81054-11	2	
3	SCREW, M8X40-8.8 HEX SOCKET HEAD CAP ZINC	F81002-29	1	
4	NUT, M8-8-B HEX NYLON ZINC LOCK	F81032-2	1	

**2.11 Wrench Set (No. 535185)**

535185\_001  
535185\_MANUAL

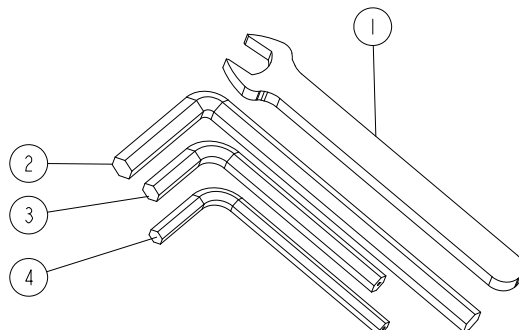

REF.	DESCRIPTION (* indicates parts available in assemblies only)	PART #	QTY	
-	<b>WRENCH SET, MP160</b>	535185	1	
1	WRENCH, 10 OPEN-END	541315	1	
2	WRENCH, 6 MM ALLEN	535186	1	
3	WRENCH, 5 ALLEN	092915	1	
4	WRENCH, 4MM ALLEN	093368	1	



## 2.12 Foot Set (No. 536996)

536996\_001  
536996\_MANUAL



REF.	DESCRIPTION (* indicates parts available in assemblies only)	PART #	QTY	
-	<b>FOOT SET</b>	536996	1	
1	FOOT	535828-1	4	
2	BOLT, M8X20MM, HEX HEAD,GR 5.8 ZINC,	F81002-4	4	
3	NUT,M8-8-B,HEX,NYLON LOCK ZINC, NUT, M8-8-B HEX NYLON ZINC LOCK	F81032-2	4	

2.13 Protective guard adjustment assembly 534170

534170\_001\_A  
534170\_MANUAL

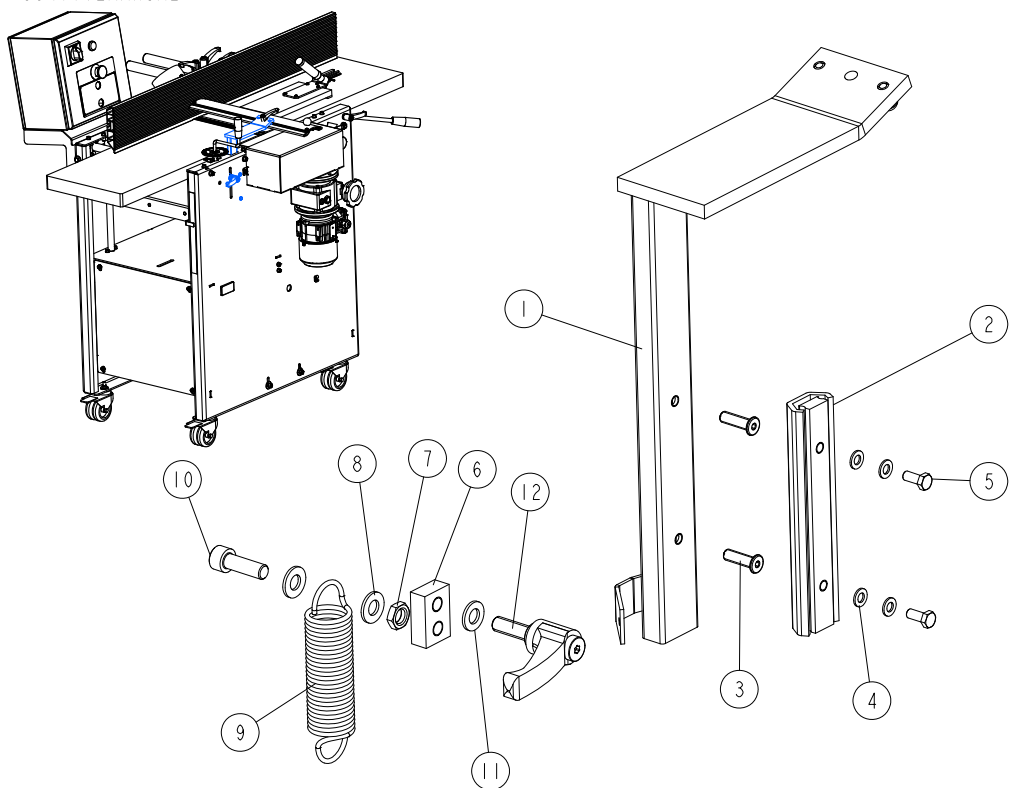

REF	DESCRIPTION (◆ indicates parts available in assemblies only)	PART #	QTY
-	<b>PROTECTIVE GUARD ADJUSTMENT ASSEMBLY</b>	534170	1
1	PROTECTIVE GUARD ADJUSTMENT ASSEMBLY	534155-1	1
2	LINEAR GUIDE	534167	1
3	SCREW, M6X20 HEX SOCKET HEAD CAP 10.9 BN	F81001-90	2
4	WASHER, M5, FLAT ZINC	F81052-1	4
5	BOLT, M5X12-5.8 HEX HEAD FULL THREAD ZIN	F81000-5	2
6	BLOCK, HOUSING MOUNT ASSEMBLY	534168-1	1
7	NUT, M8-04-FE/ZN ISO4035 HEX THIN	F81032-8	1
8	WASHER, 8.4 FLAT,ZINC	F81054-1	2
9	SPRING, 25X105X2,5	534169	1
10	SCREW, M8X25 8.8 HEX SOCKET HEAD CAP ZINC	F81002-21	1
11	WASHER, 8.4/16-1.6 PA66	546948	1
12	ADJUSTABLE HANDLE, ERZ.63P-M8X25	533591	1

## 2.14 Bottom table (No. 534352)

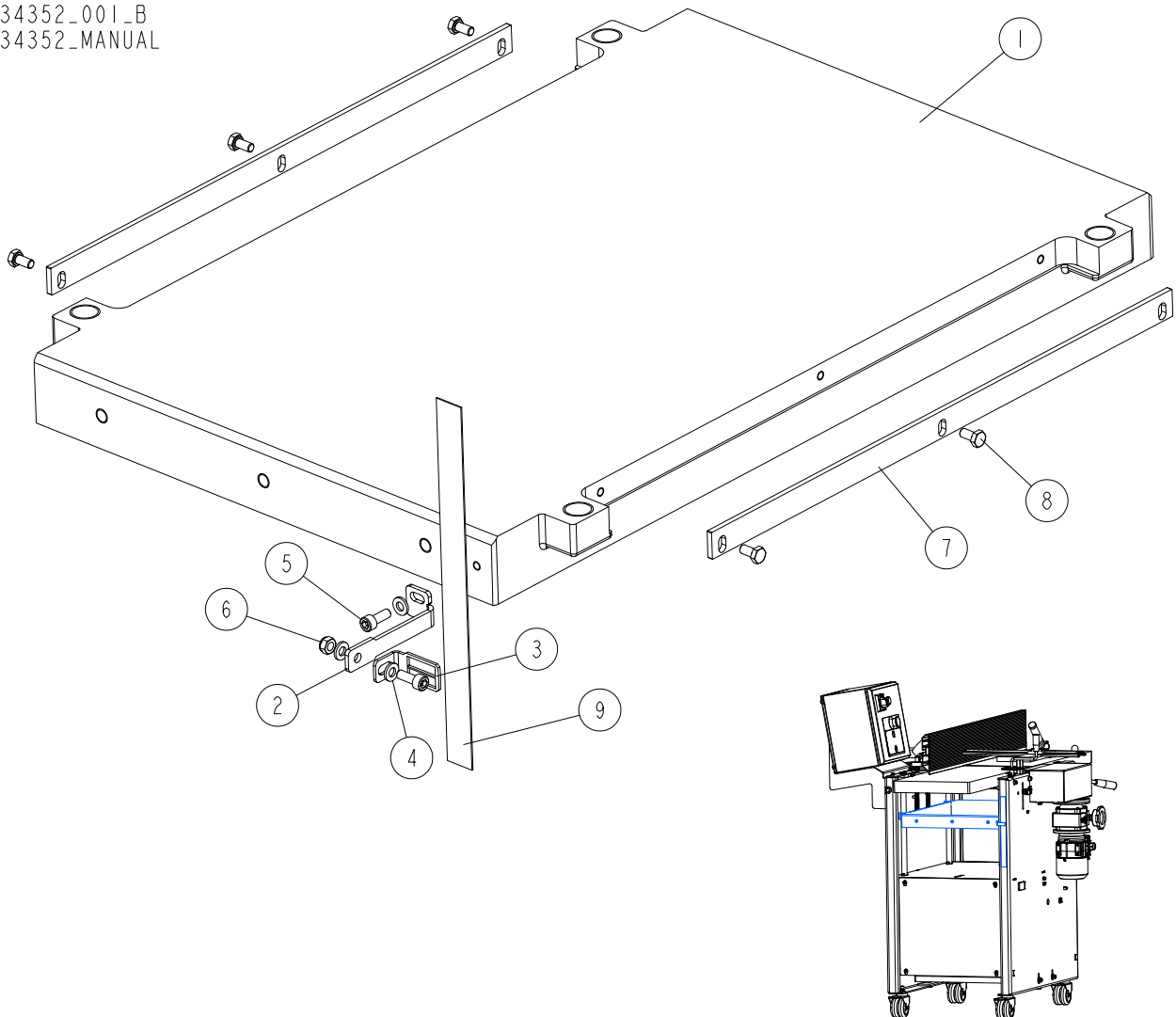
534352\_001\_B  
534352\_MANUAL

REF	DESCRIPTION (◆ indicates parts available in assemblies only)	PART #	QTY
-	TABLE, BOTTOM - COMPLETE	534352	1
1	TABLE, MP160 BOTTOM	534351-1	1
-	INDICATOR ASSEMBLY, SCALE	537740	1
2	BRACKET, INDICATOR	537741-1	1
3	INDICATOR, SCALE	537739	1
4	WASHER 6,4 ZC DIN 126 ISO 7091	F81053-1	3
5	SCREW M6X16 SHCS ZC 8.8 DIN 912 ISO 4762	F81001-21	2
6	NUT, M6-8-B HEX NYLON ZINC LOCK	F81031-2	1
7	BAR	546835-1	2
8	BOLT, M6X12 8.8 HEX HEAD FULL THREAD ZIN	F81001-7	6
9	DECAL, VERTICAL SCALE	535116	1

### 2.15 Chip channel assembly 534218

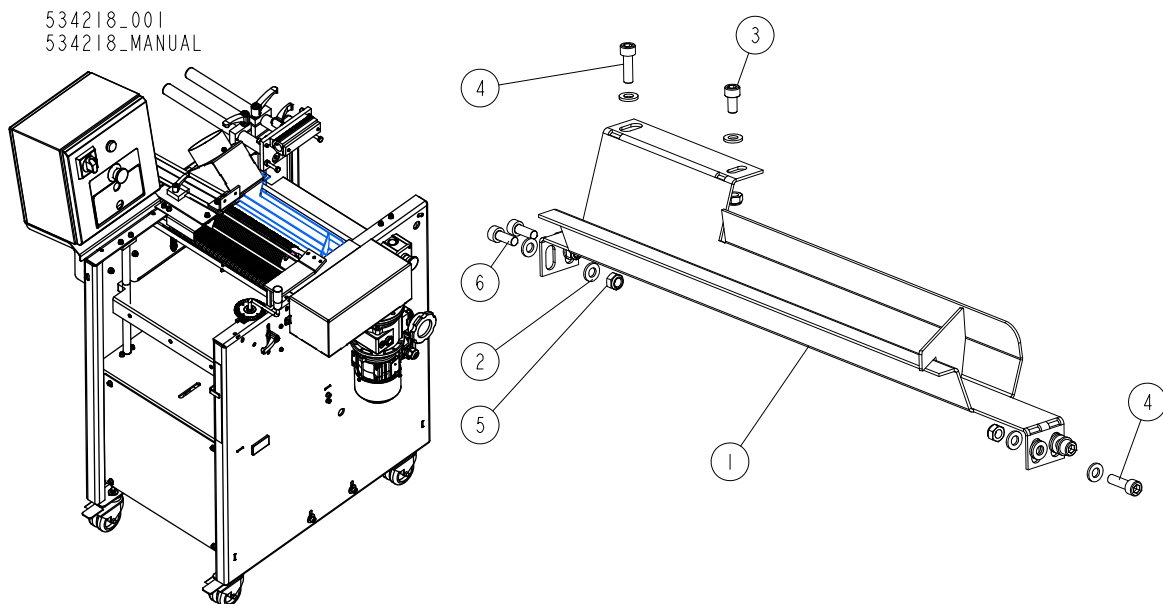

REF.	DESCRIPTION (* indicates parts available in assemblies only)	PART #	QTY
-	<b>CHIP CHANNEL ASSEMBLY</b>	534218	1
1	CHANNEL, CHIP W/PLATE	534217-1	1
2	WASHER, 6.4 FLAT ZINC	F81053-1	14
3	SCREW, ISO 4762-M6X12-8.8-A2E HEX SOCKET HEAD CAP	F81001-87	1
4	SCREW, M6X20 8.8 HEX SOCKET HEAD CAP ZINC	F81001-22	3
5	NUT, M6-8-B HEX NYLON ZINC LOCK	F81031-2	5
6	SCREW, M6X16 8.8 HEX SOCKET HEAD CAP ZINC	F81001-21	2

## 2.16 Small guard assembly 534182

534182\_001  
534182\_MANUAL

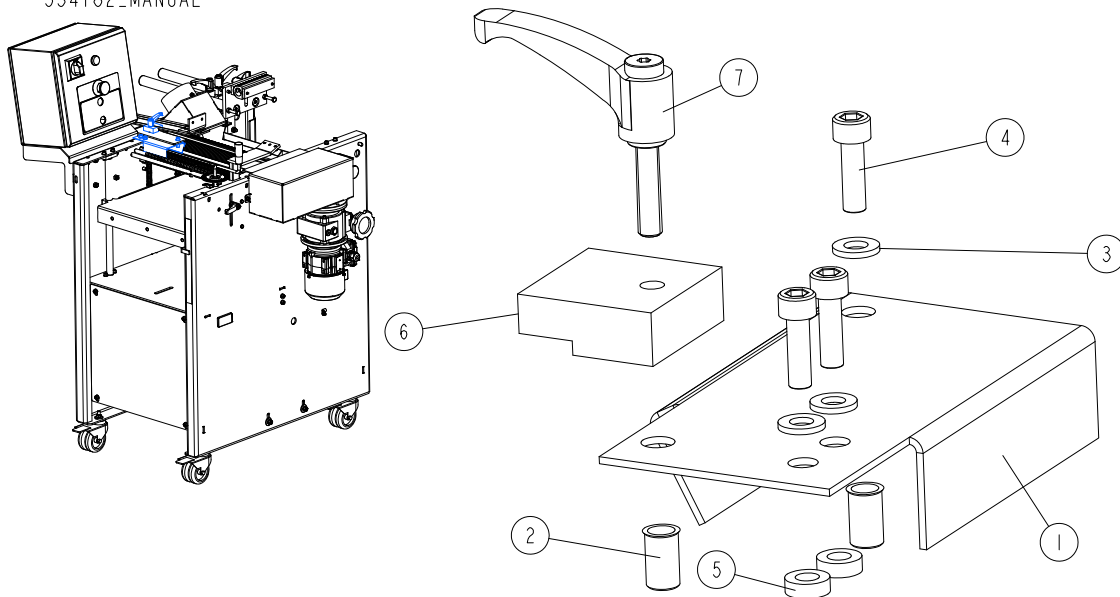

REF.	DESCRIPTION (* indicates parts available in assemblies only)	PART #	QTY
-	<b>GUARD ASSEMBLY, SMALL</b>	534182	1
1	GUARD, SMALL	534181-1	1
2	NUT, O-NIT-6-17-ZN RIVET	F81031-13	2
3	WASHER, 6.4 FLAT ZINC	F81053-1	3
4	SCREW, M6X20 8.8 HEX SOCKET HEAD CAP ZINC	F81001-22	3
5	WASHER, SPACER	534183	2
6	BLOCK, GUARD CLAMPING	534789-1	1
7	HANDLE, ERZ.44 P-M6X40 ADJUSTABLE	534790	1

**2.17 Chain tensioner assembly 534171**

534171\_001\_A  
534171\_MANUAL

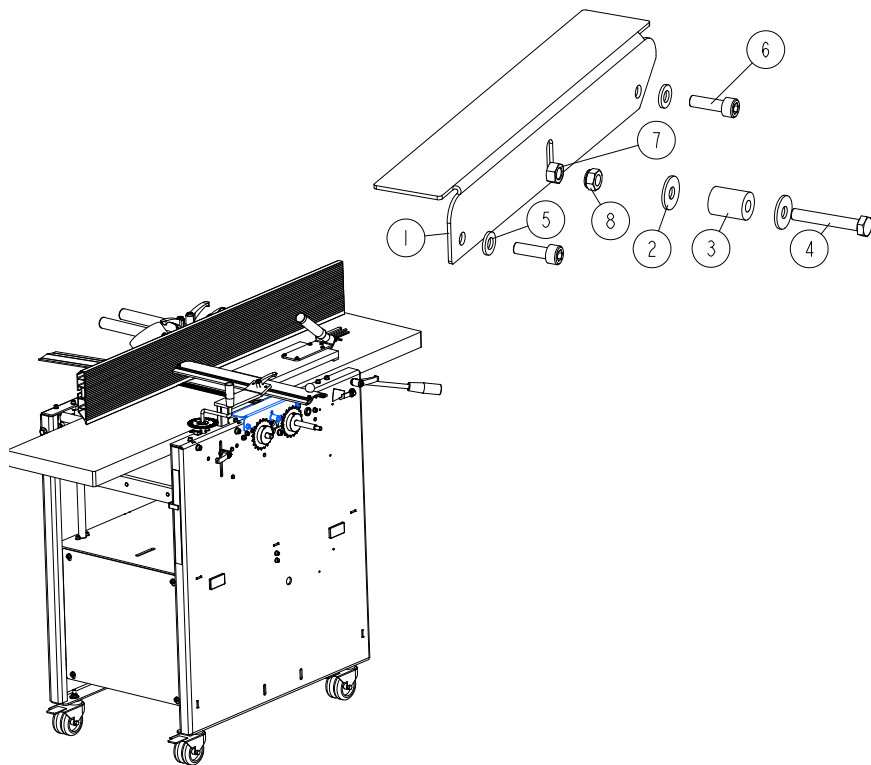

REF.	DESCRIPTION (* indicates parts available in assemblies only)	PART #	QTY
-	<b>CHAIN TENSIONER ASSEMBLY</b>	534171	1
1	PLATE, CHAIN TENSIONER	534157-1	1
2	WASHER, 6.5 ZINC SPECIAL FLAT	F81053-11	2
3	BUSHING, SPACER	R80671-6	1
4	BOLT, M6X40MM HEX HEAD FULL THREAD ZINC	F81001-5	1
5	WASHER, 6.4 FLAT ZINC	F81053-1	2
6	SCREW, M6X20 8.8 HEX SOCKET HEAD CAP ZINC	F81001-22	2
7	NUT, M6-8 HEX ZINC	F81031-1	1
8	NUT, M6-8-B HEX NYLON ZINC LOCK	F81031-2	1

## 2.18 Pusher 534166

534166\_001  
534166\_MANUAL

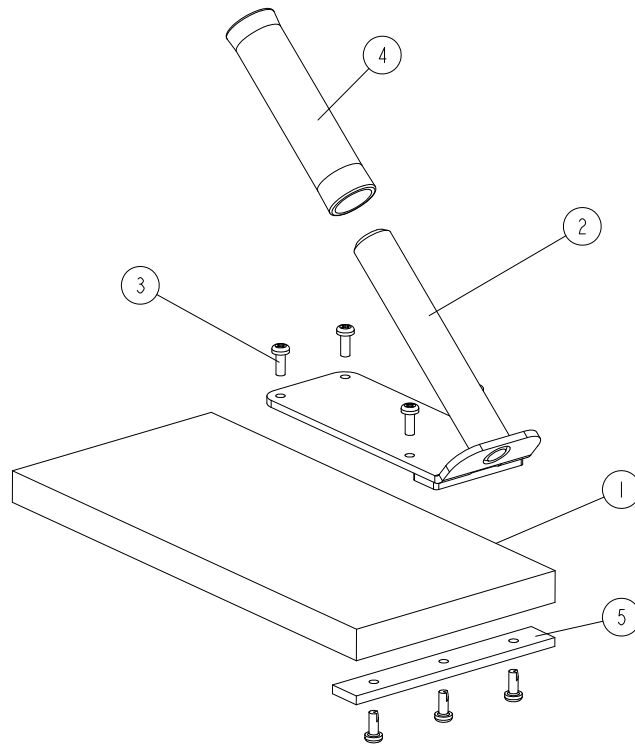
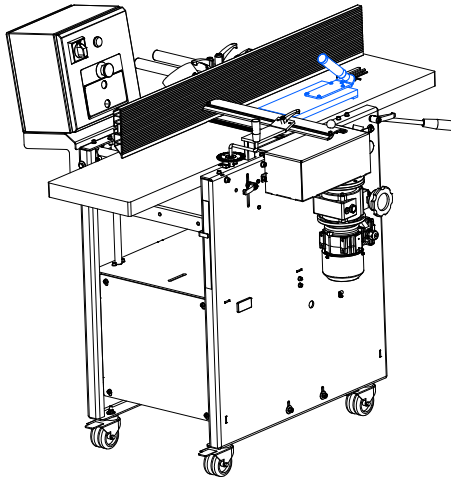

REF.	DESCRIPTION (* indicates parts available in assemblies only)	PART #	QTY	
-	<b>PUSHER</b>	534166	1	
1	PLATE, MANUAL CLAMP	534160	1	
2	MANUAL CLAMP ASSEMBLY	534165-1	1	
3	BOLT, #10-24X1/2 PH	F05015-17	7	
4	GRIP	086164	1	
5	PLATE, CLAMPING	534786-1	1	

2.19 Cutter protective cover assembly 534752

534752\_001  
534752\_MANUAL

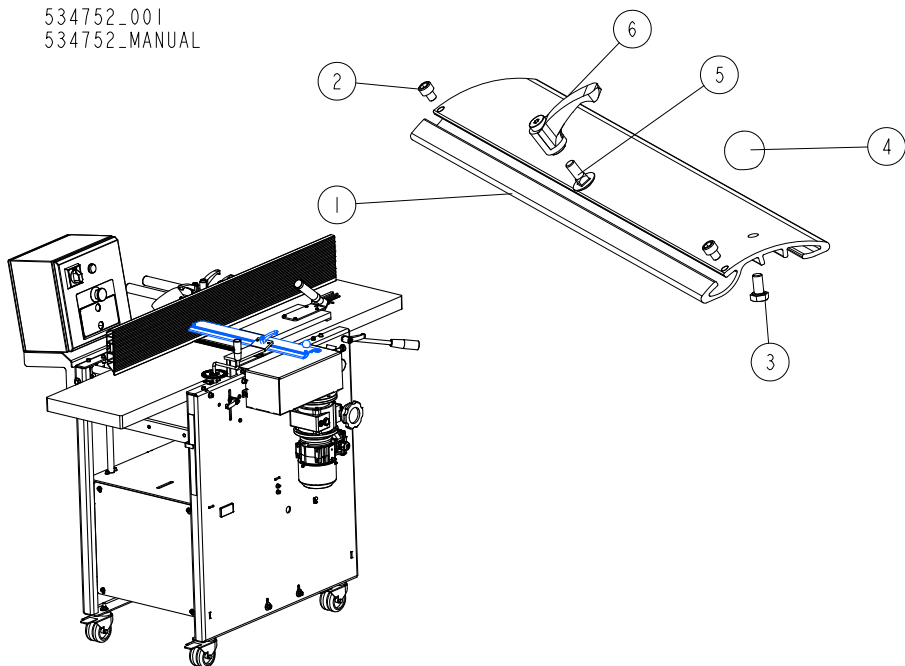

REF.	DESCRIPTION (* indicates parts available in assemblies only)	PART #	QTY
-	<b>CUTTER PROTECTIVE COVER ASSEMBLY</b>	534752	1
1	CUTTER PROTECTIVE COVER	534230	1
2	SCREW, M5X6 8.8 HEX SOCKET HEAD CAP ZINC	F81000-94	2
3	BOLT, M6X12 8.8 HEX HEAD FULL THREAD ZINC	F81001-7	1
4	KNOB, DIN 319-KU-25-M6-C ROUND	534769	1
5	BOLT, M6X16 -8.8 CARRIAGE ZINC	F81001-36	1
6	HANDLE, ERZ.44 A-M6 ADJUSTABLE	534751	1



## 2.20 Cutter assembly 534223

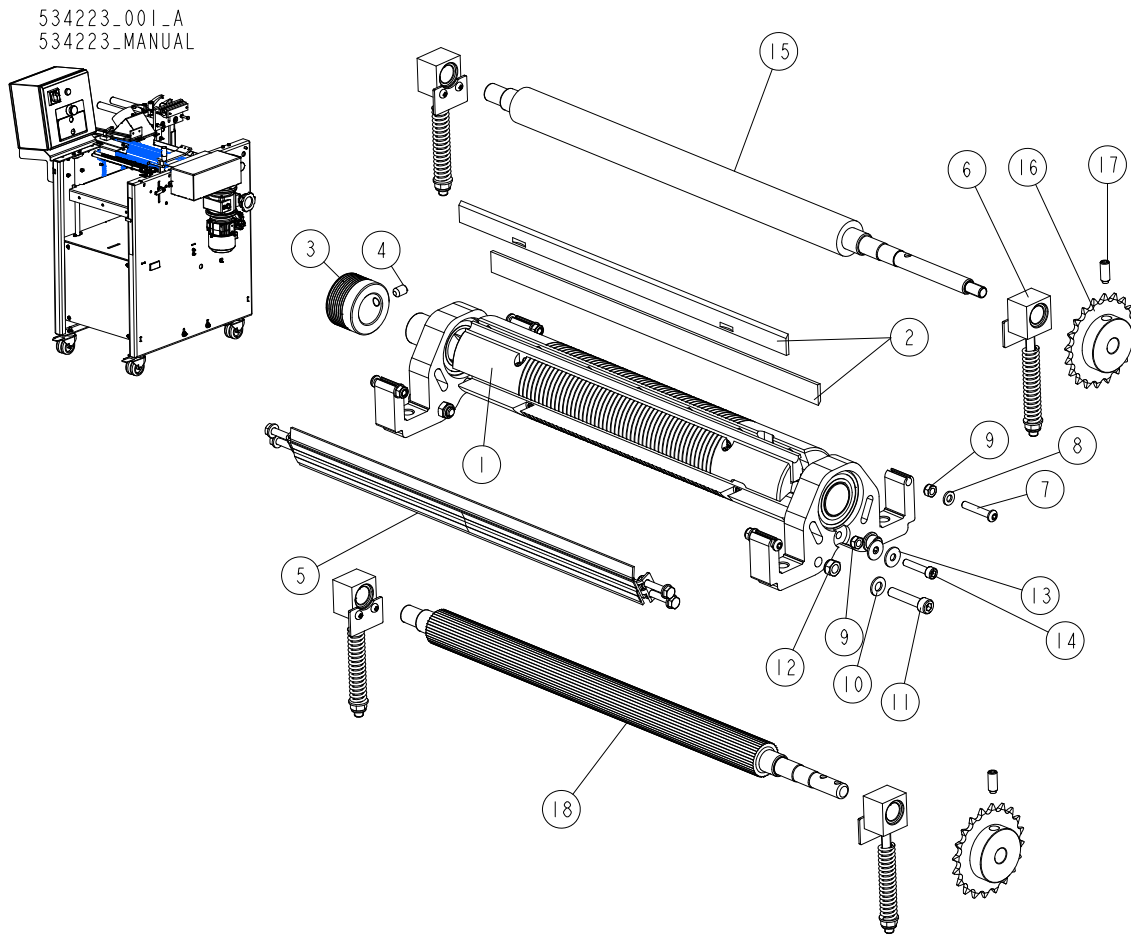

REF.	DESCRIPTION (* indicates parts available in assemblies only)	PART #	QTY
-	<b>CUTTER ASSEMBLY</b>	534223 <sup>1</sup>	1
1	CUTTER ASSEMBLY <a href="#">See Section 2.21</a>	534785	1
2	PLANER KNIFE WITH NOTCHES	TPK410.20MP	2
3	PULLEY, MULTI-GROOVE SMALL ALUMINIUM	533586	1
4	SCREW, M8X12-45H FE/ZN DIN914 HEX SOCKET SET W/CONE POINT	F81002-105	1
5	CUTTER PROTECTIVE COVER <a href="#">See Section 2.23</a>	534220	1
6	BEARING ASSEMBLY, SLIDE <a href="#">See Section 2.24</a>	534225	4
7	SCREW, M6X35 ISO 7380 ZINC SLOTTED ROUND	F81001-91	4
8	WASHER, 6.4 FLAT ZINC	F81053-1	4
9	NUT, M6-8-B HEX NYLON ZINC LOCK	F81031-2	6
10	WASHER, 8.4 FLAT ZINC	F81054-1	4
11	SCREW, M8X40-8.8 HEX SOCKET HEAD CAP ZINC	F81002-29	4
12	NUT, M8-8-B HEX NYLON ZINC LOCK	F81032-2	4
13	WASHER, 6.5 ZINC SPECIAL FLAT	F81053-11	4
14	SCREW, M6X30-8.8 HEX SOCKET HEAD CAP ZINC	F81001-42	2
15	SHAFT W/PROTECTIVE COVER	533512	1
16	SPROCKET, Z=20; 1/2"X 3/16"(CHAIN 083-1)	533109	2
17	SCREW, M8X20-45H ISO4028 DIN915 SET	F81002-77	2
18	SHAFT, STEEL DRIVE	533513-1	1

<sup>1</sup> The assembly also includes:

- 534393 - chain 083-1;p-1/2";l ength=0.4953m (39-links)
- 533128 - master link for chain 083-1 - 1 pcs.

## 2.21 Cutter assembly 534785

534785\_001  
534785\_MANUAL

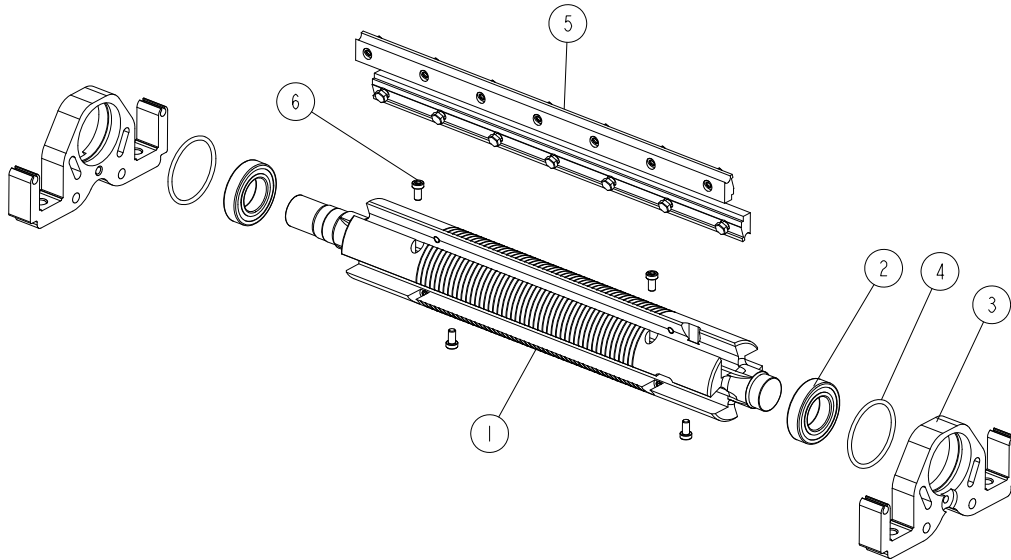

REF.	DESCRIPTION (* indicates parts available in assemblies only)	PART #	QTY	
-	<b>CUTTER ASSEMBLY</b>	534785	1	
1	SHAFT, MAIN	260-138	1	
2	BEARING, 6006 2RSR	096191	2	
3	HOUSING, CUTTER PLUMMER BLOCK	534222-1	2	
4	O-RING, BEARING HOUSING	534224	2	
5	WEDGE SET, MOUNTING	241-060	1	
6	SCREW, M6X12-10.9 DIN 7984 LOW HEX SOCKET HEAD CAP	F81001-80	4	

2.22 Helical Top Cutter assembly THH160TC-S

THH160TC-S\_001  
THH160TC-S

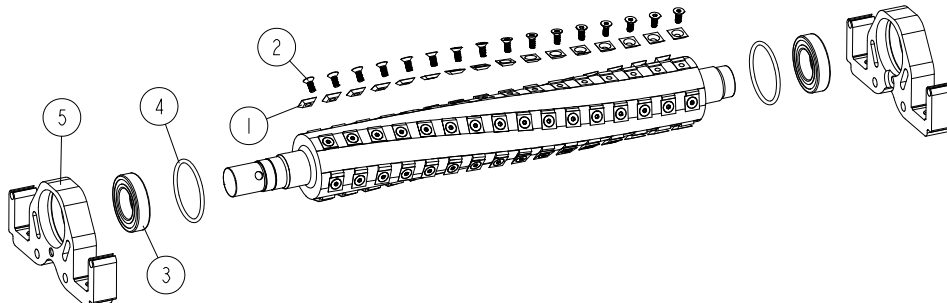

REF	DESCRIPTION (u indicates parts available in assemblies only)	PART #	QTY
-	<b>KIT, MP160 HELICAL TOP CUTTERHEAD</b>	THH160TC-S	1
-	CUTTERHEAD, HELICAL THH260TC	THH260TC	1
1	INSERT, REPLACEMENT CARBIDE	TIK19HM	80
2	SCREW, 10-32X1/2 FH BO; TORX PLUS	F05004-325	80
3	BEARING, 6006 2RSR	096191	2
4	O-RING, BEARING HOUSING	534224	2
5	HOUSING, CUTTER PLUMMER BLOCK	534222-1	2

**2.23 Cutter Guard (No. 534220)**

534220\_001\_A  
534220\_MANUAL

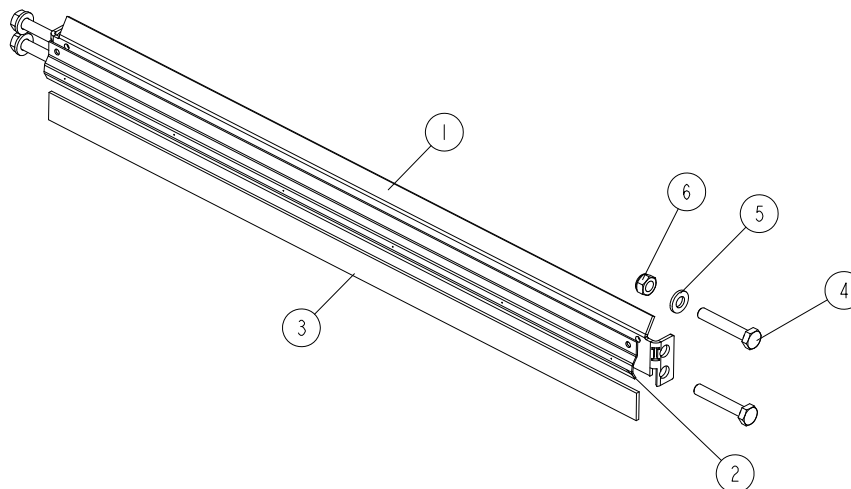

REF.	DESCRIPTION (* indicates parts available in assemblies only)	PART NO.	QTY
-	<b>GUARD, CUTTER - COMPLETE</b>	534220	1
	GUIDE ASSEMBLY, SAWDUST	535830	
	MOUNT ASSEMBLY, RUBBER STRIP	535827	
1	PLATE, RUBBER STRIP MOUNT	534159	1
2	PLATE, RUBBER STRIP CLAMP	534212	1
3	STRIP, RUBBER	534221	1
4	BOLT, M6x35-8.8 HEX HEAD ZINC	F81001-71	4
5	WASHER, 6.4 FLAT ZINC	F81053-1	4
6	NUT, M6-8-B HEX NYLON ZINC LOCK	F81031-2	4

## 2.24 Bearing assembly 534225

534225\_001\_B  
534225\_MANUAL

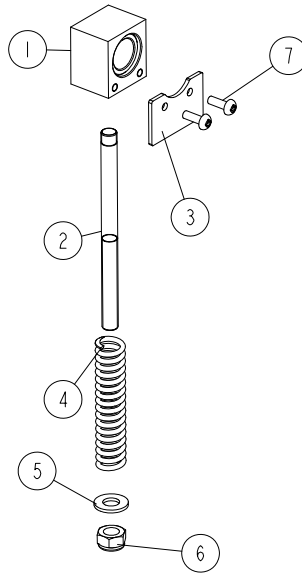

REF	DESCRIPTION (◆ indicates parts available in assemblies only)	PART #	QTY	
-	SLIDE BEARING ASSEMBLY	534225	1	
1	SLIDE BLOCK ASSEMBLY	537575	1	
2	ROD, SHAFT TENSION	546898-1	1	
3	COVER, RUBBER	533516	1	
4	SPRING	533519-1	1	
5	WASHER, 8.4 FLAT,ZINC	F81054-1	1	
6	NUT, M8-8-B HEX NYLON ZINC LOCK	F81032-2	1	
7	SCREW M4X12 PHILLIPS ZC 5.8 DIN 7985	F81011-43	2	

## 2.25 Upper outfeed table 534205

534205\_001\_B  
534205\_MANUAL  
534205\_001\_B  
534205\_MANUAL

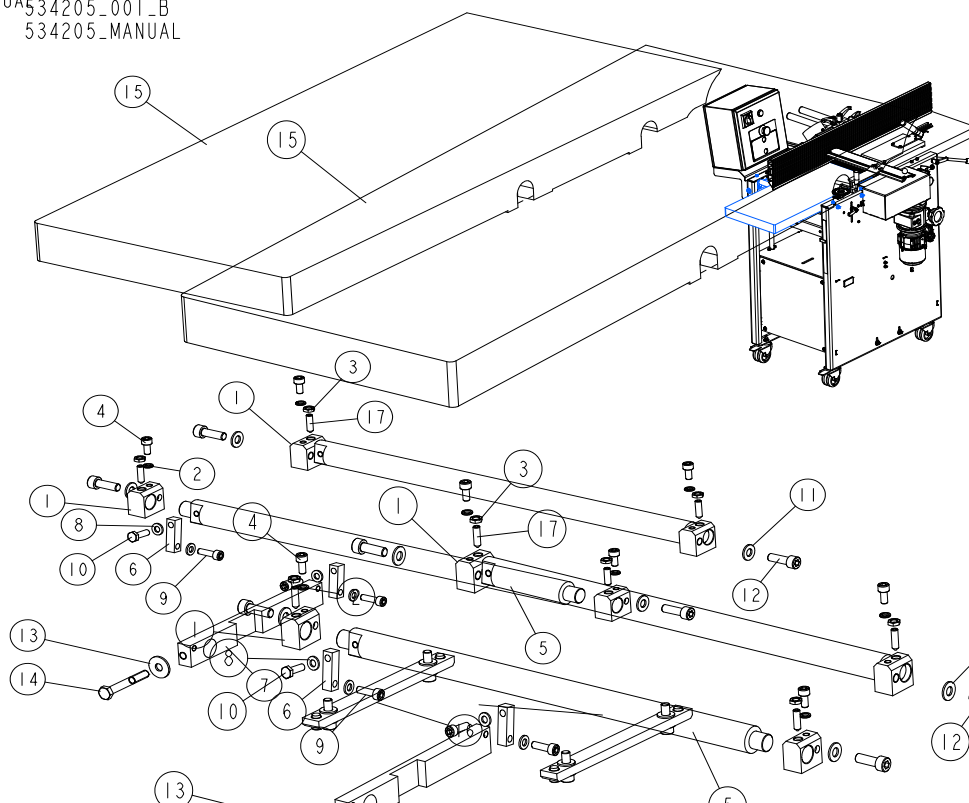

REF	DESCRIPTION (u indicates parts available in assemblies only)	PART #	QTY
-	<b>UPPER OUTFEED TABLE- COMPLETE</b>	534205	1
1	BLOCK	561711	4
2	WASHER, Z 6.1 SPLIT LOCK ZINC	F81053-3	4
3	NUT, M8 DIN 439 ISO 4035 THIN	F81031-14	4
4	SCREW M6X12 SHCS ZC 8.8 DIN 912 ISO 4762	F81001-87	4
5	SHAFT, ECCENTRIC	534204	2
6	BLOCK	534206-1	2
7	BAR	534207-1	1
8	WASHER, 6.4 FLAT ZINC	F81053-1	4
9	SCREW, M6X20 8.8 SOCKET HEAD	F81001-22	3
10	BOLT, M6X20 8.8 HEX HEAD FULL THREAD ZIN	F81001-2	1
11	WASHER, 8.4 FLAT ZINC	F81054-1	4
12	SCREW, M8X25 8.8 HEX SOCKET HEAD CAP ZIN	F81002-21	4
13	WASHER, .85 FE/ZN5 PN-59/M-82030	F81054-11	1
14	BOLT, M8X60-8.8 HEX HEAD ZINC	F81002-54	1
15	TABLE, MP160 OUTFEED	534354-1	1
16	MOUNTING BAR ASSEMBLY	534357	2
17	SCREW M6X20 45H PN84-M/82315	F81001-127	4

## 2.26 Mounting bar assembly 534357

534357\_001  
534357\_MANUAL

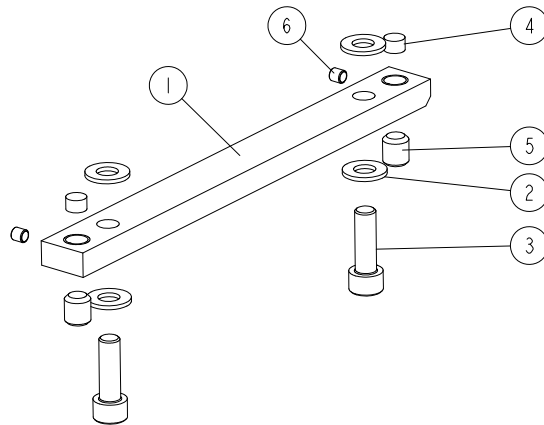

REF.	DESCRIPTION (* indicates parts available in assemblies only)	PART #	QTY
-	<b>MOUNTING BAR ASSEMBLY</b>	534357	1
1	BAR	534356-1	1
2	WASHER, 8.4 FLAT ZINC	F81054-1	4
3	SCREW, M8X25 8.8 HEX SOCKET HEAD CAP ZINC	F81002-21	2
4	PIN, ADJUSTMENT	534358	2
5	SCREW, M10X12-45H ZINC-PLATED SET	F81003-46	2
6	SCREW, M5X5-45H-DIN 916 HEX SOCKET SET WITH CUP POINT	F81000-92	2



## 2.27 Fence assembly 534185

534185\_002  
534185\_MANUAL

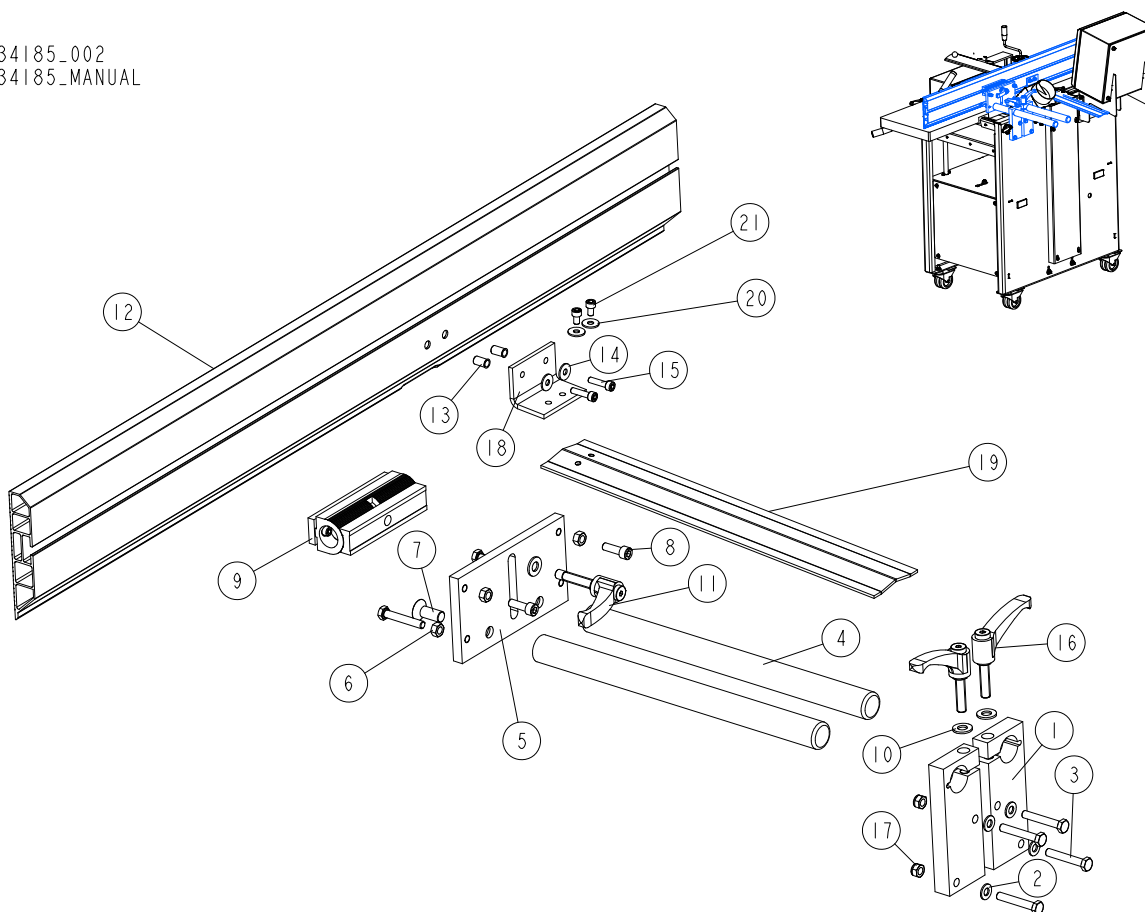

REF.	DESCRIPTION (* indicates parts available in assemblies only)	PART #	QTY
-	<b>FENCE ASSEMBLY</b>	534185	1
1	BRACKET, FENCE GUIDE MOUNTING	534184-1	2
2	WASHER, 8.4 FLAT ZINC	F81054-1	4
3	BOLT, M8X50 -8.8 HEX HEAD FULL THREAD ZINC	F81002-19	6
4	ROD	534187	2
5	PLATE, FENCE GUIDE	534186-1	1
6	NUT, M8-8-B HEX ZINC	F81032-1	4
7	SCREW, M12X30-10.9 FLAT SOCKET HEAD CAP	F81004-18	2
8	SCREW, M8X25 8.8 HEX SOCKET HEAD CAP ZINC	F81002-21	2
9	FENCE ADJUSTMENT ASSEMBLY <a href="#">See Section 2.28</a>	534213	1
10	WASHER, 10.5 FLAT ZINC	F81055-1	3
11	HANDLE, ERZ.78 P-M10X50 ADJUSTABLE	534214	1
-	FENCE, GUIDE	534219	1
12	FENCE, GUIDE	534215	1
13	NUT, O-NIT-6-17-ZN RIVET	F81031-13	2
14	WASHER, 6.5 ZINC SPECIAL FLAT	F81053-11	2
15	SCREW, M6X25 -8.8-FE/ZN5 HEX SOCKET HEAD	F81001-41	2
16	HANDLE, ERZ.78 P-M10X40 ADJUSTABLE	533536	2

REF.	DESCRIPTION (* indicates parts available in assemblies only)	PART #	QTY	
17	NUT, M8-8-B HEX NYLON ZINC LOCK	F81032-2	4	
18	BRACKET, RUBBER CONNECTING	534788	1	
19	PLATE, CUTTER COVER	534787-1	1	
20	WASHER, 6.5 ZINC SPECIAL FLAT	F81053-11	2	
21	SCREW, M6X10 8.8 HEX SOCKET HEAD CAP ZINC	F81001-12	2	

**2.28 Adjuster Assembly, Fence Panel (No. 534213)**

534213\_001  
534213\_MANUAL

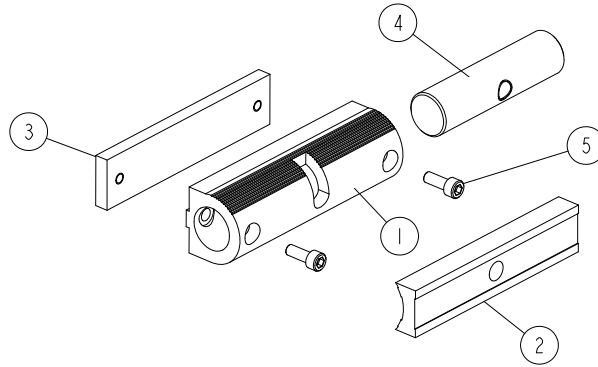

REF.	DESCRIPTION (* indicates parts available in assemblies only)	PART #	QTY	
-	<b>ADJUSTER ASSEMBLY, FENCE PANEL</b>	534213	1	
1	BLOCK, PANEL ADJUSTMENT (2)	534189	1	
2	BLOCK, ANGLE ADJUSTMENT (1)	534188	1	
3	PLATE, K3 PANEL ADJUSTMENT	534210-1	1	
4	SHAFT, PANEL ADJUSTER	534211	1	
5	SCREW, M6X16 8.8 HEX SOCKET HEAD CAP ZINC	F81001-21	2	

## 2.29 Upper infeed table 534355

534355\_001  
534355\_MANUAL

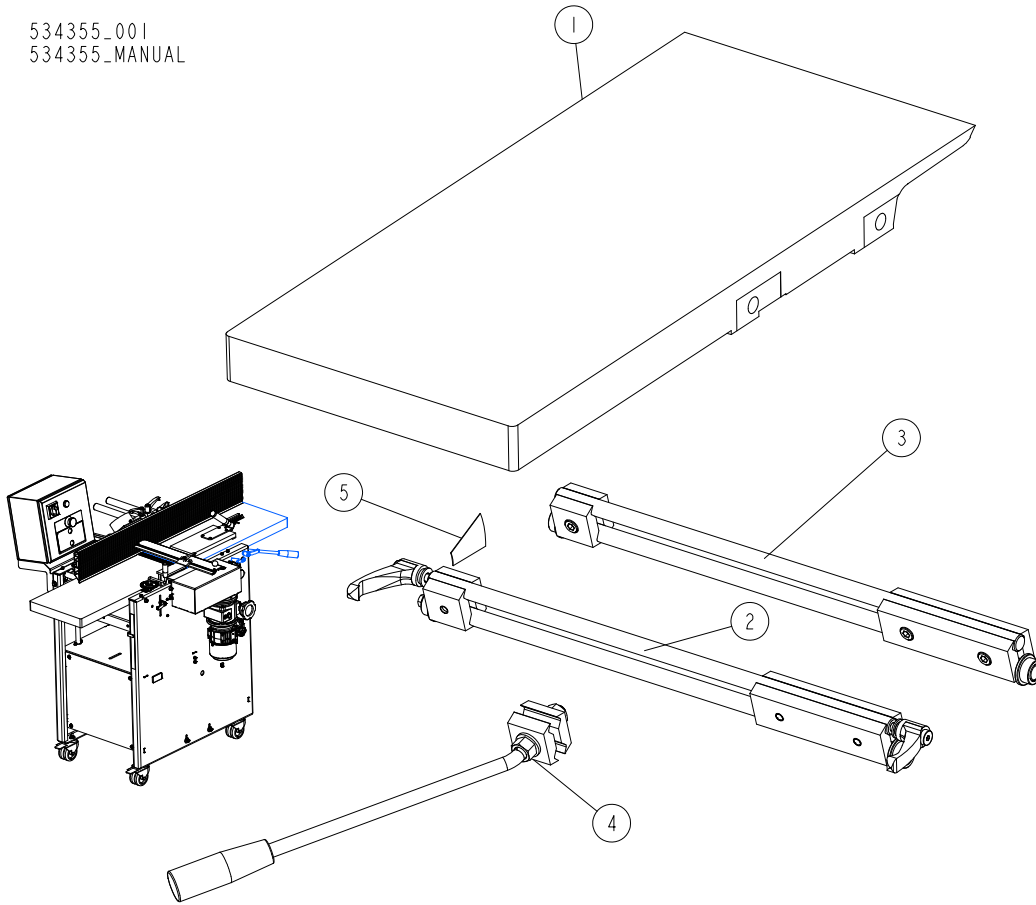

REF.	DESCRIPTION (* indicates parts available in assemblies only)	PART #	QTY	
-	TABLE, UPPER INFEED - COMPLETE	534355	1	
1	TABLE, MP160 INFEED	534353-1	1	
2	FRONT GUIDE RAIL ASSEMBLY, COMPLETE <a href="#">See Section 2.30</a>	534375	1	
3	REAR GUIDE RAIL ASSEMBLY, COMPLETE <a href="#">See Section 2.31</a>	534376	1	
4	HANDLE, INFEED TABLE ADJUSTMENT <a href="#">See Section 2.32</a>	534380	1	
5	DECAL	534203	1	

**2.30 Front guide rail assembly 534375**

534375\_001\_A  
534375\_MANUAL

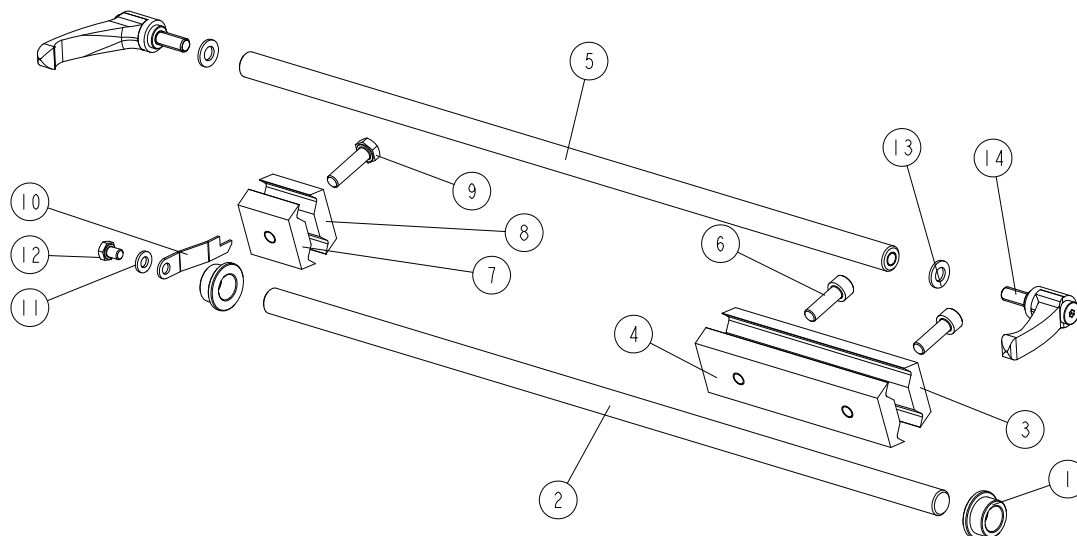

REF	DESCRIPTION (◆ indicates parts available in assemblies only)	PART #	QTY
-	<b>FRONT GUIDE RAIL ASSEMBLY, COMPLETE</b>	534375	1
1	BUSHING 15/22-12 FLANGED 28-3	534359	2
2	SHAFT, N15X512	534371	1
3	BRACKET, GUIDE RAIL RIGHT	534363-1	1
4	BRACKET, GUIDE RAIL RIGHT	534364-1	1
5	SHAFT, N15X492	534372	1
6	SCREW, M8X25 8.8 HEX SOCKET HEAD CAP ZINC	F81002-21	2
7	BRACKET, GUIDE RAIL	534362-1	1
8	BRACKET, GUIDE RAL	534365-1	1
9	BOLT M8X30 HH ZC FT 8.8 DIN 933	F81002-7	1
10	INDICATOR, SCALE	534377-1	1
11	WASHER, M6, FLAT,ZINC	F81053-1	1
12	BOLT, M6X8-8.8 HEX HEAD FULL THREAD ZINC	F81001-33	1
13	WASHER, 8.4/16-1.6 PA66	546948	2
14	HAND LEVER, ERZ. 63P-M8X20 ADJUSTABLE	534378	2

### 2.31 Rear guide rail assembly 534376

534376\_001  
534376\_MANUAL

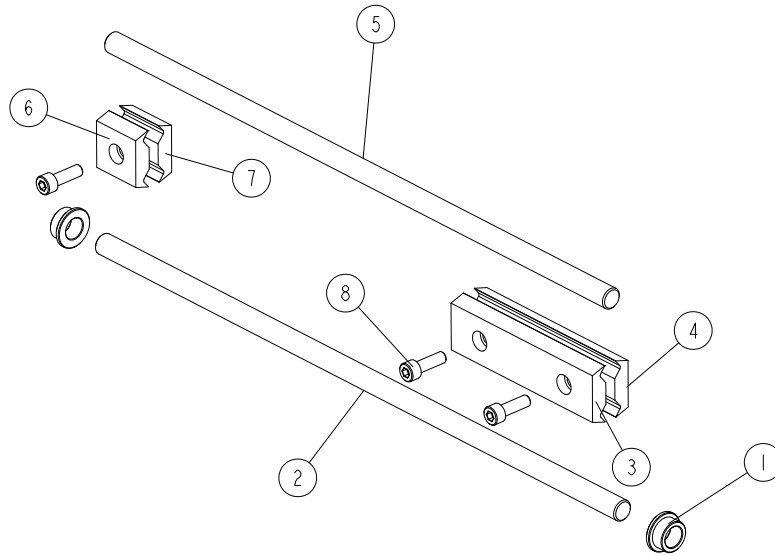

REF.	DESCRIPTION (* indicates parts available in assemblies only)	PART #	QTY
-	<b>REAR GUIDE RAIL ASSEMBLY, COMPLETE</b>	534376	1
1	BUSHING, 15/22-12 FLANGED 28-3	534359	2
2	SHAFT, LLN15X512	534374	1
3	BRACKET, GUIDE RAIL RIGHT	534363-1	1
4	BRACKET, GUIDE RAIL RIGHT	534364-1	1
5	SHAFT, LLN15X492	534373	1
6	BRACKET, GUIDE RAIL	534361-1	1
7	BRACKET, GUIDE RAIL	534362-1	1
8	SCREW, M8X25 8.8 HEX SOCKET HEAD CAP ZINC	F81002-21	3

**2.32 Infeed table adjustment handle 534380**

534380\_001  
534380\_MANUAL

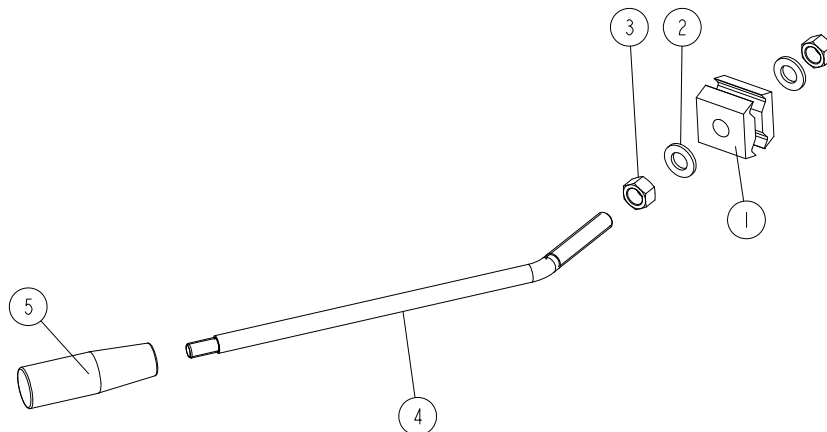

REF.	DESCRIPTION (* indicates parts available in assemblies only)	PART #	QTY
-	<b>INFEED TABLE ADJUSTMENT HANDLE, COMPLETE</b>	534380	1
1	BRACKET, HANDLE	534366-1	2
2	WASHER, 13 FLAT ZINC	F81056-1	2
3	NUT, M12-8 HEX ZINC	F81034-1	2
4	ROD, M12	534379-1	1
5	GRIP, K1202.11028 C TAPERED	534381	1

### 2.33 Up/down Assembly 534385

534385\_001\_A  
534385\_MANUAL

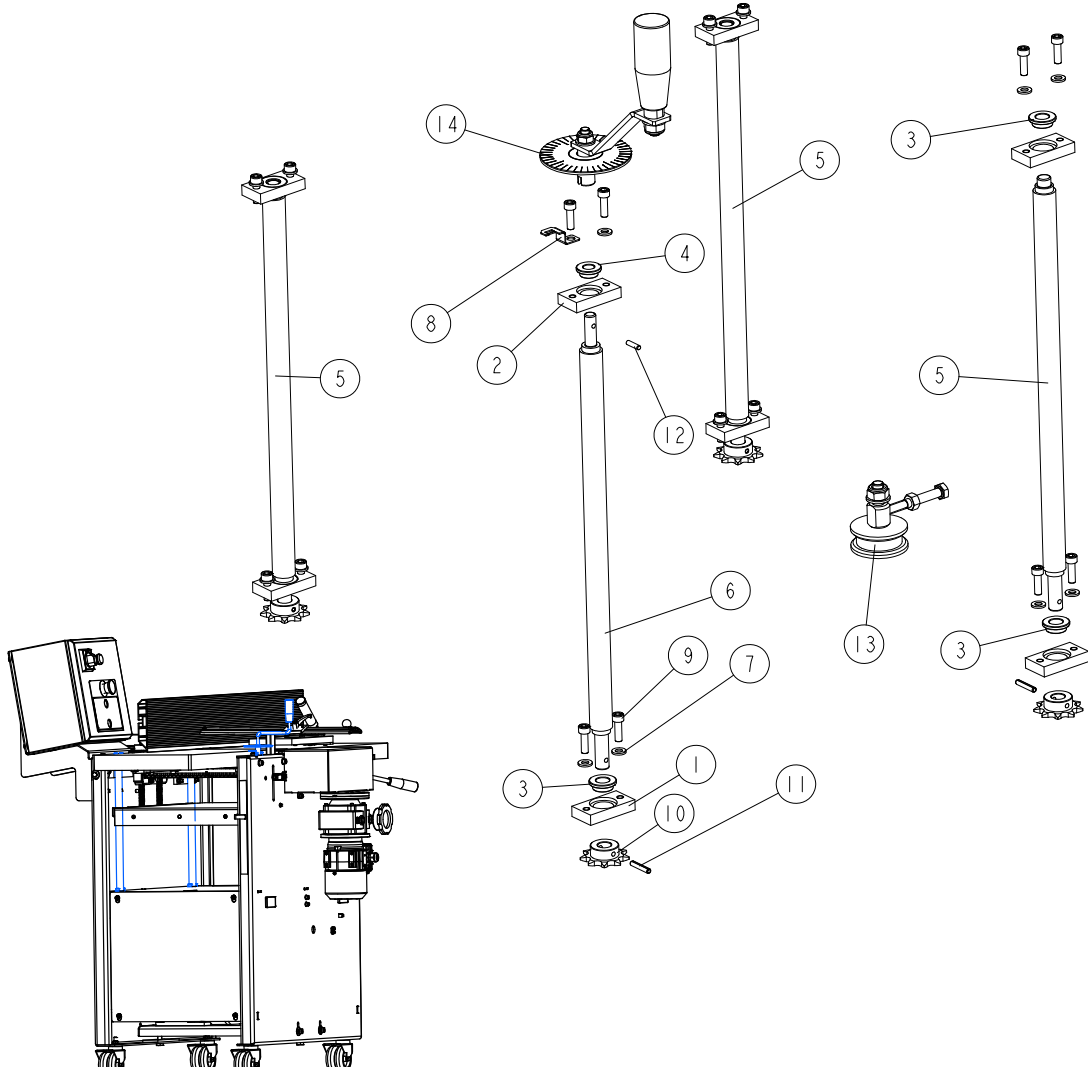

REF.	DESCRIPTION (* indicates parts available in assemblies only)	PART #	QTY
-	UP/DOWN ASSEMBLY	534385 <sup>1</sup>	1
1	BLOCK	533113-1	7
2	BLOCK 2	546903-1	1
3	BUSHING, 12/18-8 FLANGED 24-3	546901	7
4	BUSHING, 10/16-8 FLANGED 22-3	546902	1
5	SCREW, TR20X4 L=424 ACME	534386	3
6	SCREW, TR20X4 L=445 ACME	534387	1
7	WASHER, 6.4 FLAT ZINC	F81053-1	15
8	INDICATOR, SCALE	534395	1
9	SCREW, M6X20 8.8 HEX SOCKET HEAD CAP ZINC	F81001-22	16
10	SPROCKET, Z=9; 1/2"X 3/16"(CHAIN 083-1)	533111	4
11	PIN, 4X24 ZINC-PLATED SPRING TYPE	F81044-13	4
12	PIN, ISO8734-4H6X16-ST HARDENED ROLL	F81048-85	1



REF.	DESCRIPTION (* indicates parts available in assemblies only)	PART #	QTY	
13	TENSIONER, CHAIN - COMPLETE <a href="#">See Section 2.34</a>	534390	1	
14	KNOB AND SCALE ASSEMBLY <a href="#">See Section 2.35</a>	534760	1	

<sup>1</sup> The assembly also includes:

-534391 - chain 083-1;p-1/2"; length=2.0193m (159-links)

-533128 - master link for chain 083-1

## 2.34 Chain Tensioner (No. 534390)

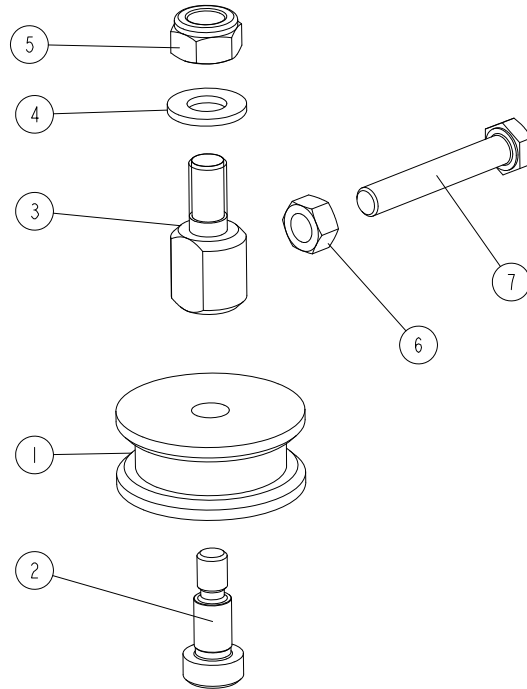
534390\_001  
534390\_MANUAL

REF.	DESCRIPTION (* indicates parts available in assemblies only)	PART #	QTY
-	<b>TENSIONER, CHAIN - COMPLETE</b>	534390	1
1	ROLLER, CHAIN TENSIONER	533576	1
2	BOLT, ISO 7379-10-M8-16 12.9 SHOULDER	F81003-139	1
3	BOLT, MOUNTING	534388-1	1
4	WASHER, 10.5 FLAT ZINC	F81055-1	1
5	NUT, M10-8-B HEX NYLON ZINC LOCK	F81033-1	1
6	NUT, M8-8-B HEX ZINC	F81032-1	1
7	BOLT, M8X50 -8.8 HEX HEAD FULL THREAD ZINC	F81002-19	1

2.35 Knob and scale assembly 534760

534760\_001\_A  
534760\_MANUAL

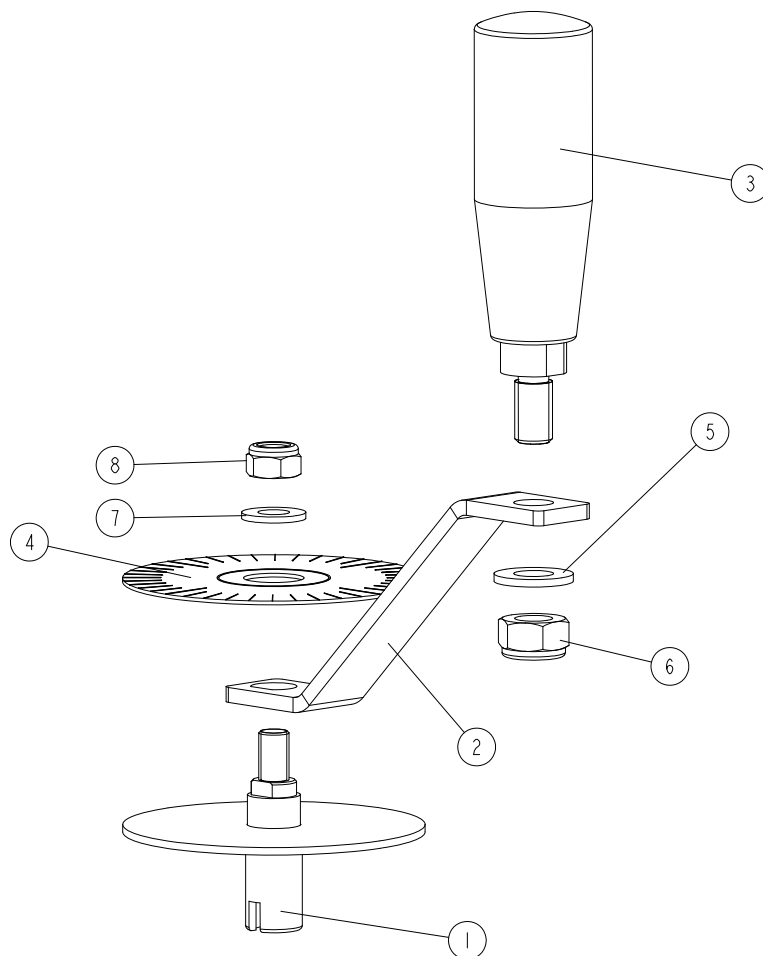

Ref	DESCRIPTION (* indicates parts available in assemblies only)	PART #	QTY
-	HANDLE WITH SHIELD	534760	1
1	KNOB ASSEMBLY	534758-1	1
2	HANDLE PLATE	541457-1	1
3	REVOLVING GRIP	535974	1
4	DECAL, MP200 ROUND SCALE	533577	1
5	WASHER 10,5 ZC DIN 126 ISO 7091	F81055-1	1
6	NUT M10 ZC 8 NYLOCK DIN 982 ISO 7040	F81033-1	1
7	WASHER 8,4 ZC DIN 126 ISO 7091	F81054-1	1
8	NUT M8 ZC 8 NYLOCK DIN 982 ISO 7040	F81032-2	1

## SECTION 3 Motor kits, 534198, 534197

### 3.1 MP160 Motor Kits PRO 534198, ECO 534197

534198\_001  
 534198\_MANUAL

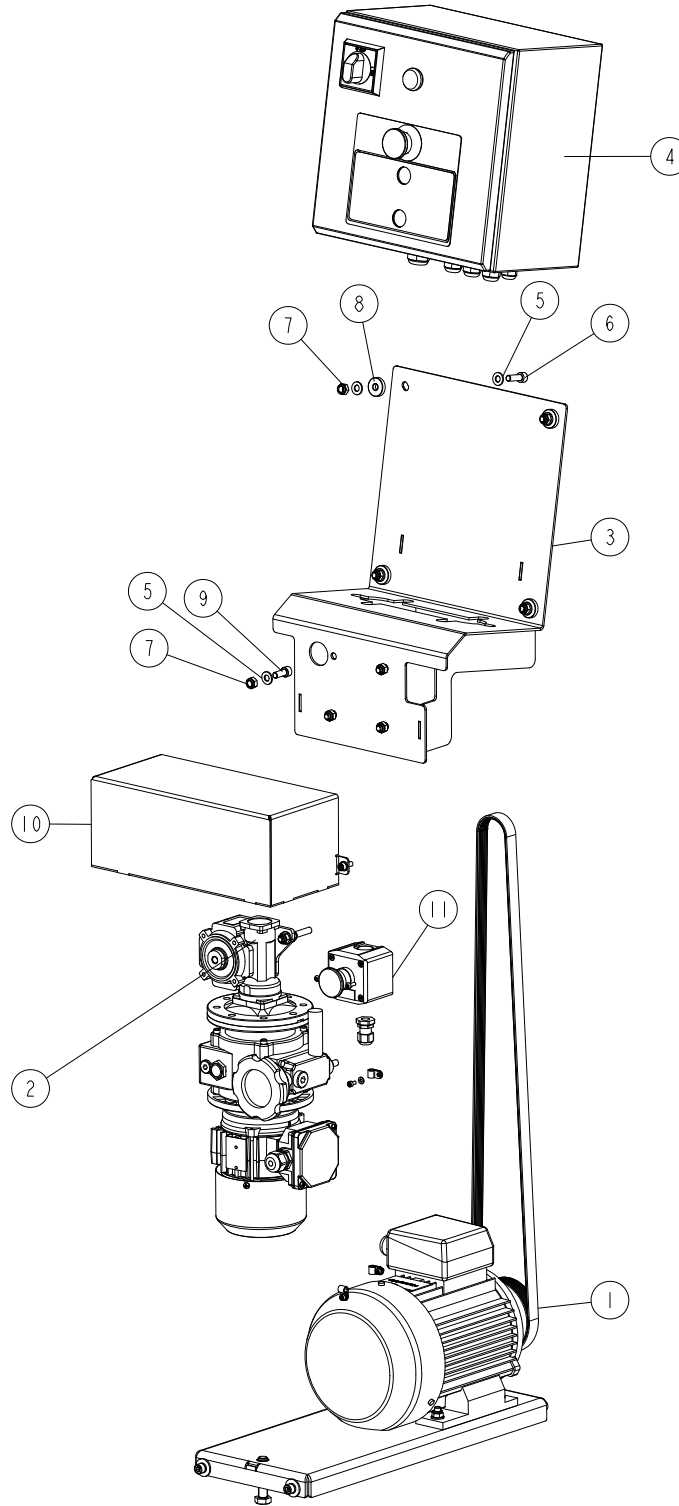

REF.	DESCRIPTION (* indicates parts available in assemblies only)	PART #	QTY
-	MOTOR KIT, PRO MP160EH 3x400V CE	534198	



# Motor kits, 534198, 534197

MP160 Motor Kits PRO 534198, ECO 534197

REF.	DESCRIPTION (* indicates parts available in assemblies only)	PART #	QTY
	MOTOR KIT, PRO MP160EB 3x230V CE	534198-2	
	MOTOR KIT, PRO MP160EBU 3x230V UL	534198-2U	
	MOTOR KIT, PRO MP160EC 3x460V CE	534198-4	
	MOTOR KIT, PRO MP160ECU 3x400V UL	534198-4U	
	MOTOR KIT, PRO MP160EA 1x230V CE	534198-6	
	MOTOR KIT, PRO MP160EAU 1x230V UL	534198-6U	
-	MOTOR KIT, ECO MP160EH 3x400V CE	534197	
	MOTOR KIT, ECO MP160EB 3x230V CE	534197-2	
	MOTOR KIT, ECO MP160EBU 3x230V UL	534197-2U	
	MOTOR KIT, ECO MP160EC 3x460V CE	534197-4	
	MOTOR KIT, ECO MP160ECU 3x400V UL	534197-4U	
	MOTOR KIT, ECO MP160EA 1x230V CE	534197-6	
	MOTOR KIT, ECO MP160EAU 1x230V UL	534197-6U	
1	DRIVE, MP200 SIDE CUTTER <a href="#">See Section 3.2</a>	534196	1
2	DRIVE, MP160 PRO FEED <a href="#">See Section 3.4</a>	533650-160	1
	DRIVE, MP160 ECO FEED <a href="#">See Section 3.3</a>	533638	1
3	MOUNT ASSEMBLY, ELECTRIC BOX	534762-1	1
4	BOX, ELECTRIC - COMPLETE <a href="#">See Section 3.5</a>	532805	1
5	WASHER, 8.4 FLAT ZINC	F81054-1	12
6	SCREW, M8X25 8.8 HEX SOCKET HEAD CAP ZINC	F81002-21	4
7	NUT, M8-8-B HEX NYLON ZINC LOCK	F81032-2	8
8	WASHER, 8.5/25-6 POLYAMIDE	523952	4
9	SCREW, M8X20-8.8 HEX SOCKET HEAD CAP ZINC	F81002-30	4
10	GUARD, MP160 PRO <a href="#">See Section 3.6</a>	534776	1
	GUARD, MP160 UL <a href="#">See Section 3.7</a> <sup>1</sup>	570009	1
11	SWITCH ASSEMBLY, MP160 EMERGENCY STOP <a href="#">See Section 3.8</a>	535669	1

<sup>1</sup> American version only

## 3.2 Cutting Head Drive 534196

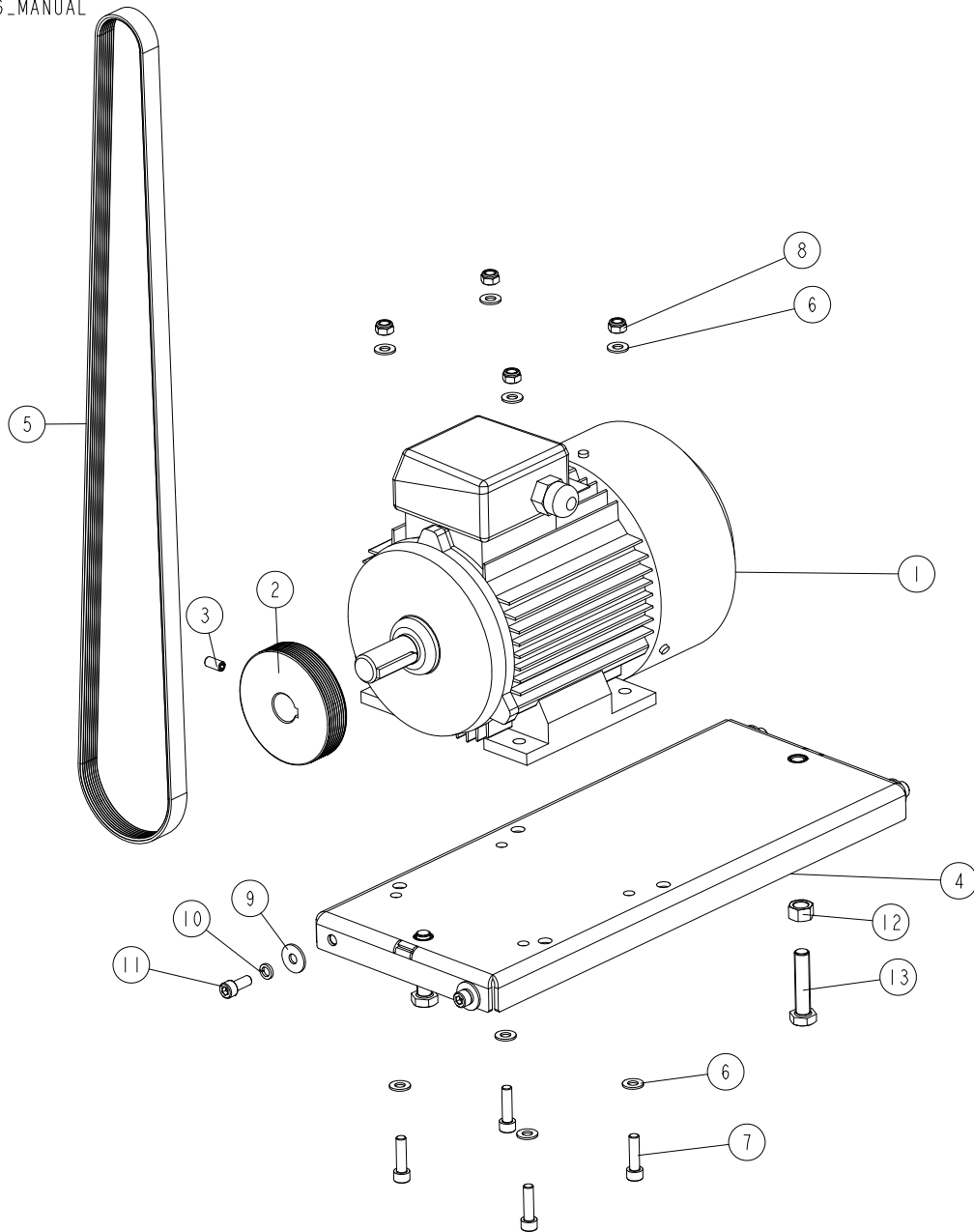
534196\_001\_B  
534196\_MANUAL

Ref	DESCRIPTION (* indicates parts available in assemblies only)	PART #	QTY
-	<b>CUTTING HEAD DRIVE</b>	534196	1
1	MOTOR 3SIE90L2A, 3KW, 2900 R.P.M, 50HZ	537386	1
2	PULLEY, MULTI-GROOVE ALUMINIUM	533585	1
3	SCREW M8X16 HSS W/FLAT POINT ZC 45H DIN	F81002-124	1
4	MOTOR PLATE WELDED / PAINT	534200-1	1
5	BELT, 8 PJ 1549 MULTI-RIBBED	534201	1
6	WASHER 8,4 ZC DIN 126 ISO 7091	F81054-1	8
7	SCREW M8X30 SHCS ZC 8.8 DIN 912 ISO 4762	F81002-31	4
8	NUT M8 ZC 8 NYLOCK DIN 982 ISO 7040	F81032-2	4
9	WASHER 8,5 ZC FENDER DIN 9021 ISO 7093	F81054-11	4

Ref	DESCRIPTION (* indicates parts available in assemblies only)	PART #	QTY	
10	WASHER 8,2 ZC SPRING LOCK DIN 127	F81054-4	4	
11	SCREW M8X20 SHCS ZC 8.8 DIN 912 ISO 4762	F81002-30	4	
12	NUT M12 ZC 8 DIN 934	F81034-1	2	
13	BOLT M12X55 HH ZC FT 8.8 DIN 933	F81004-43	2	

### 3.3 ECO Feed drive 533638

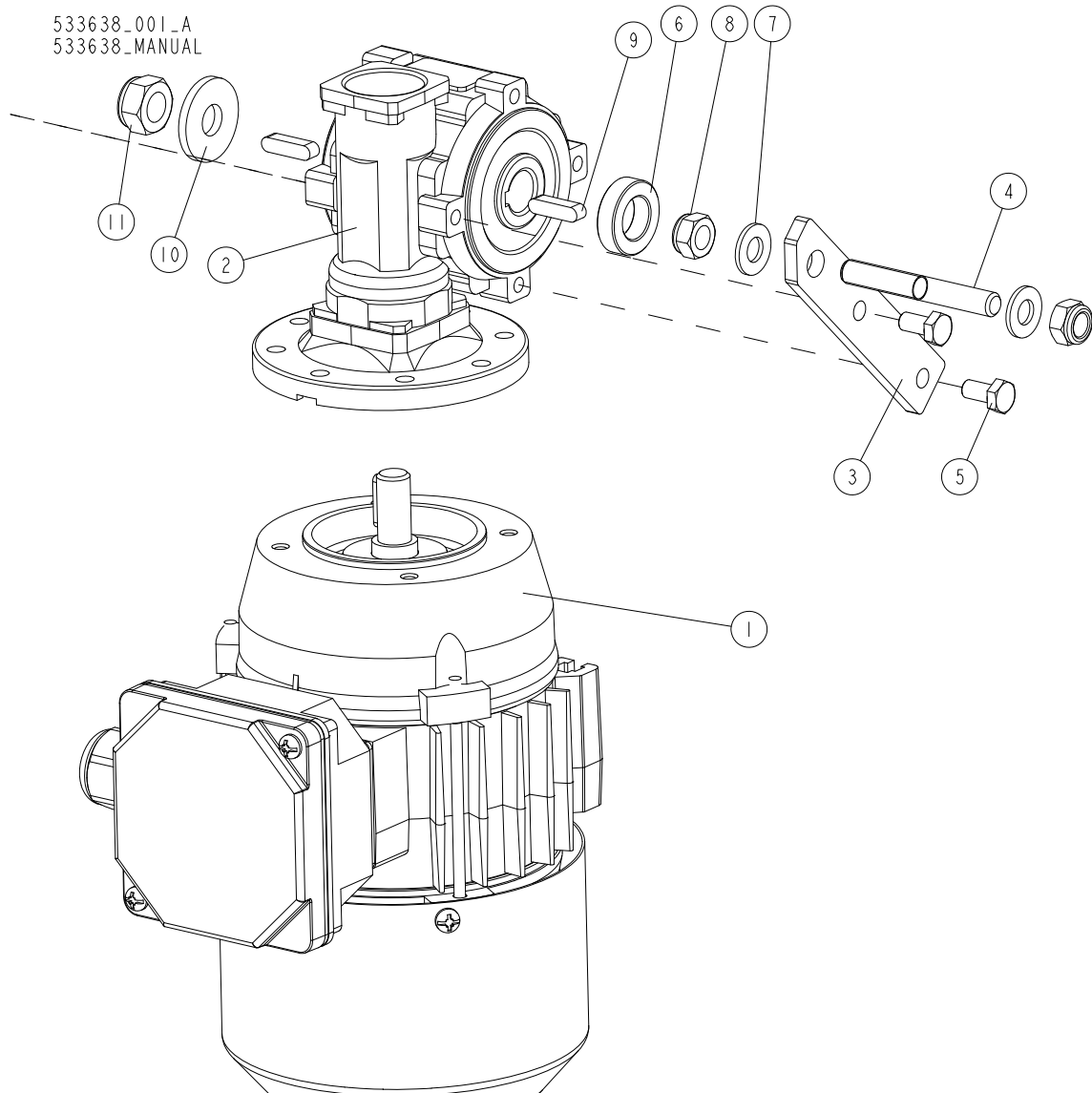

Ref	DESCRIPTION (* indicates parts available in assemblies only)	PART #	QTY
-	<b>DRIVE, MP200 ECO FEED</b>	533638	1
-	MOTOREDUCER, KC30/P30+SKH63-4B2/X	533639	1
1	MOTOR, SKH63-4B2 (0.18KW; 1370 R.P.M.)	532802	1
2	REDUCER, KC30/P30 90/11 V6	533637	1
3	ARM, TORQUE	533634-1	1
4	BOLT, M8	533635-1	1
5	BOLT M6X12 HH ZC FT 8.8 DIN 933	F81001-7	2
6	BUSHING, 14.3/25-7 ZINC-PLATED	533636-1	1
7	WASHER 8,4 ZC DIN 126 ISO 7091	F81054-1	2
8	NUT M8 ZC 8 NYLOCK DIN 982 ISO 7040	F81032-2	2
9	KEY, A5X5X20 PARALLEL	513320	2
10	WASHER 10,5 ZC FENDER DIN 9021 ISO 7093	F81055-6	1
11	NUT M10 ZC 8 NYLOCK DIN 982 ISO 7040	F81033-1	1



### 3.4 PRO Feed drive 533650

533650\_001\_A  
533650\_MANUAL

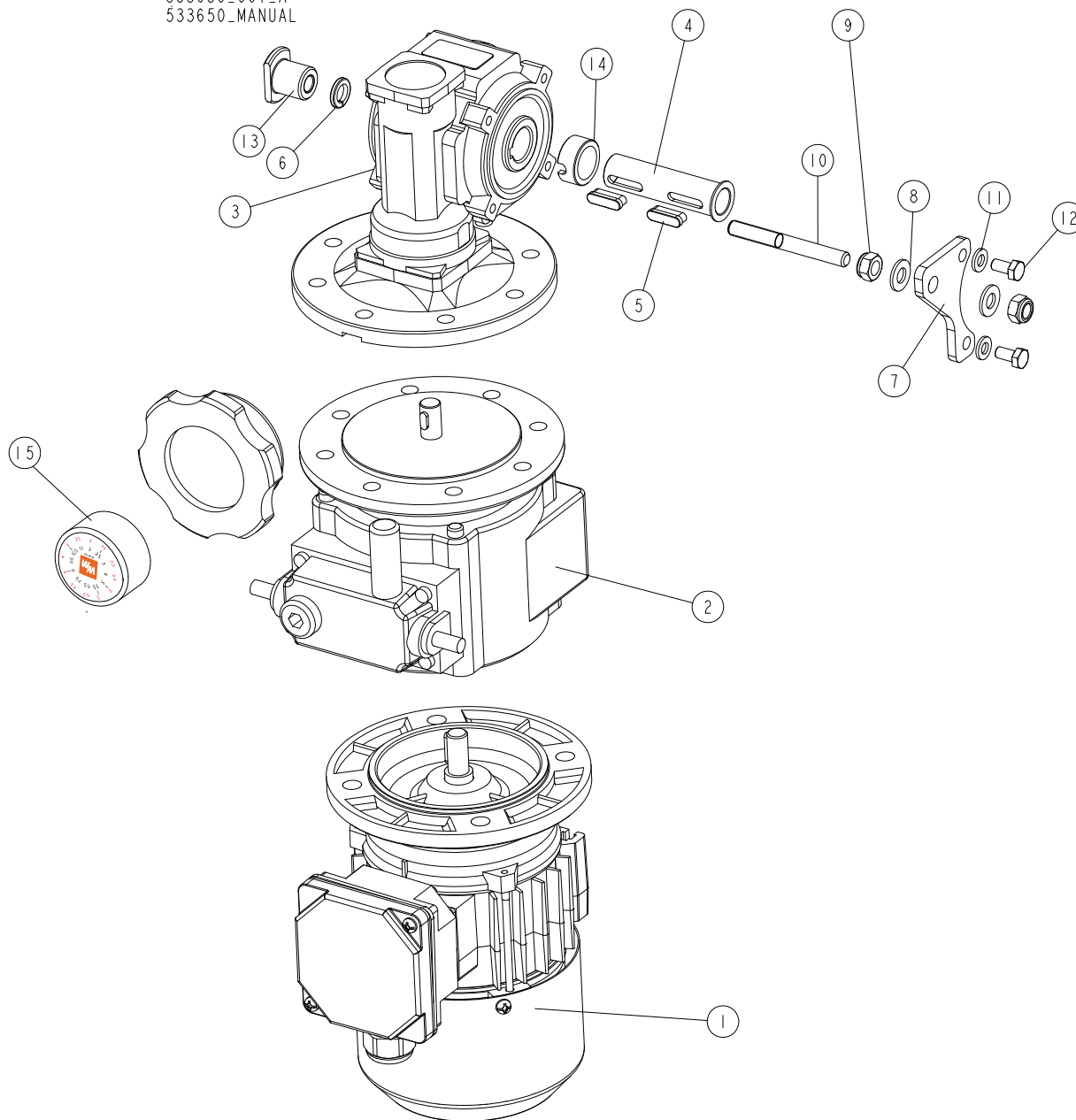

REF.	DESCRIPTION (* indicates parts available in assemblies only)	PART #	QTY
-	DRIVE, PRO FEED	533650	1
-	DRIVE, MP160 PRO FEED	533650-160	1
-	DRIVE, MP180 PRO FEED	533650-180	1
	PRO MOTION DRIVE F/B MP180 AU	533650-180AU <sup>1</sup>	1
	PRO MOTION DRIVE F/B MP180 UL	533650-180U <sup>2</sup>	1
	REDUCER, PRO KC40/P15+NF003+SKH63-2C	533640	1
1	MOTOR SKH63-B (0.37 KW; 2800 REV/MIN)	533642 <sup>3</sup>	1
1	MOTOR, SEMKH71-2C/X+NF005 160/14+KC40/P	532807-UL <sup>4</sup>	1
1	MOTOREDUCER KC40/P 15+ NF003 + SKH63-2	533640-UL <sup>5</sup>	1

REF.	DESCRIPTION (* indicates parts available in assemblies only)	PART #	QTY	
2	SPEED VARIATOR NF003 140/11 V3	533643	1	
3	REDUCER KC40 P15 63 B5 V6 H18 3D	533641	1	
4	BUSHING, REDUCER	533731	1	
5	KEY	533732	2	
6	WASHER, Z 10.2 SPLIT LOCK ZINC	F81055-2	1	
7	ARM, TORQUE	533734-1	1	
8	WASHER, 8.4 FLAT ZINC	F81054-1	2	
9	NUT, M8-8-B HEX NYLON ZINC LOCK	F81032-2	2	
10	BOLT, M8	533635-1-6U	1	
11	WASHER, 6.4 FLAT ZINC	F81053-1	2	
12	BOLT, M6X12 8.8 HEX HEAD FULL THREAD ZINC	F81001-7	2	
13	NUT, M10	533733-1-6U	1	
14	BUSHING, REDUCER	541449 <sup>6</sup>	1	
15	INDICATOR, POSITION (GRAVITY DRIVE)	546883	1	

<sup>1</sup> American version only

<sup>2</sup> American version only

<sup>3</sup> For other voltage version see motor's specification in the operation manual.

<sup>4</sup> Included in 533650-180AU

<sup>5</sup> Included in 533650-180U

<sup>6</sup> Not Included In 533650-160

### 3.5 Electric box 532805

532805\_001  
532805\_MANUAL

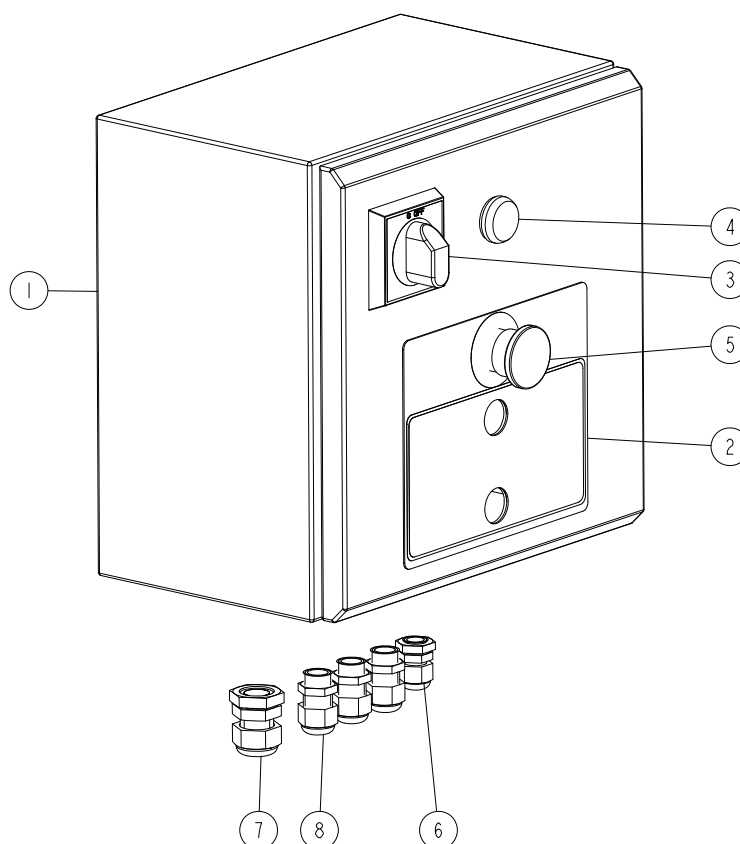

REF.	DESCRIPTION (* indicates parts available in assemblies only)	PART #	QTY
-	BOX, ELECTRIC - COMPLETE MP160EH 3X400V CE	532805 <sup>1</sup>	
	BOX, ELECTRIC - COMPLETE MP160EB 3X230V CE	532805-2 <sup>2</sup>	
	BOX, ELECTRIC - COMPLETE MP160EBU 3X230V UL	532805-2U	
	BOX, ELECTRIC - COMPLETE MP160EC 3X460V CE	532805-4	
	BOX, ELECTRIC - COMPLETE MP160ECU 3X460V UL	532805-4U	
	BOX, ELECTRIC - COMPLETE MP160EA 1X230V CE	532805-6	
	BOX, ELECTRIC - COMPLETE MP160EAU 1X230V UL	532805-6U	
1	BOX, ELECTRIC MP 200	534763	1
2	DECAL, ELECTRIC BOX	534765	1
3	HANDLE, ABB SWITCH	088265-1	1
4	LIGHT, M22 LED 24V BLUE CONTROL	090448	1
5	SWITCH, XB4 BS542 EMERGENCY STOP	086556	1
6	GLAND, DP9/H CABLE	F81096-2	1
7	GLAND, DP16/H CABLE	F81096-7	1
8	GLAND, DW11/H CABLE	085388	3

<sup>1</sup> Optional power supply kit (cable with plug) - 539809-1

<sup>2</sup> Optional power supply kit (cable with plug) - 539809

### 3.6 Cover MP160 534776

534776\_001  
534776\_MANUAL

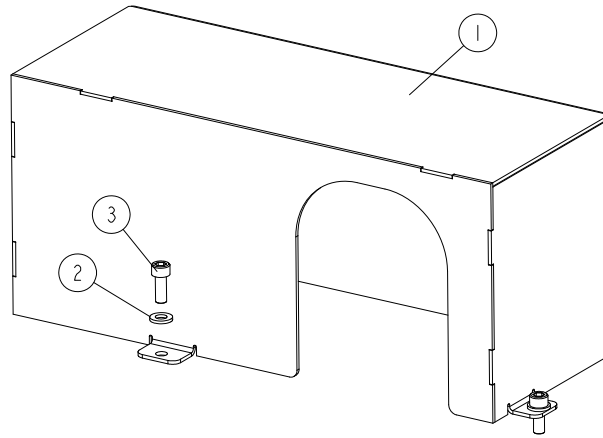

Ref	DESCRIPTION (* indicates parts available in assemblies only)	PART #	QTY	
-	<b>COVER MP160 PRO</b>	534776	1	
1	WELDING COVER, MP160 PRO	534778-1	1	
2	WASHER 6,4 ZC DIN 126 ISO 7091	F81053-1	3	
3	SCREW M6X16 SHCS ZC 8.8 DIN 912 ISO 4762	F81001-21	3	



### 3.7 Cover MP160 UL 570009

570009\_001  
570009\_MANUAL

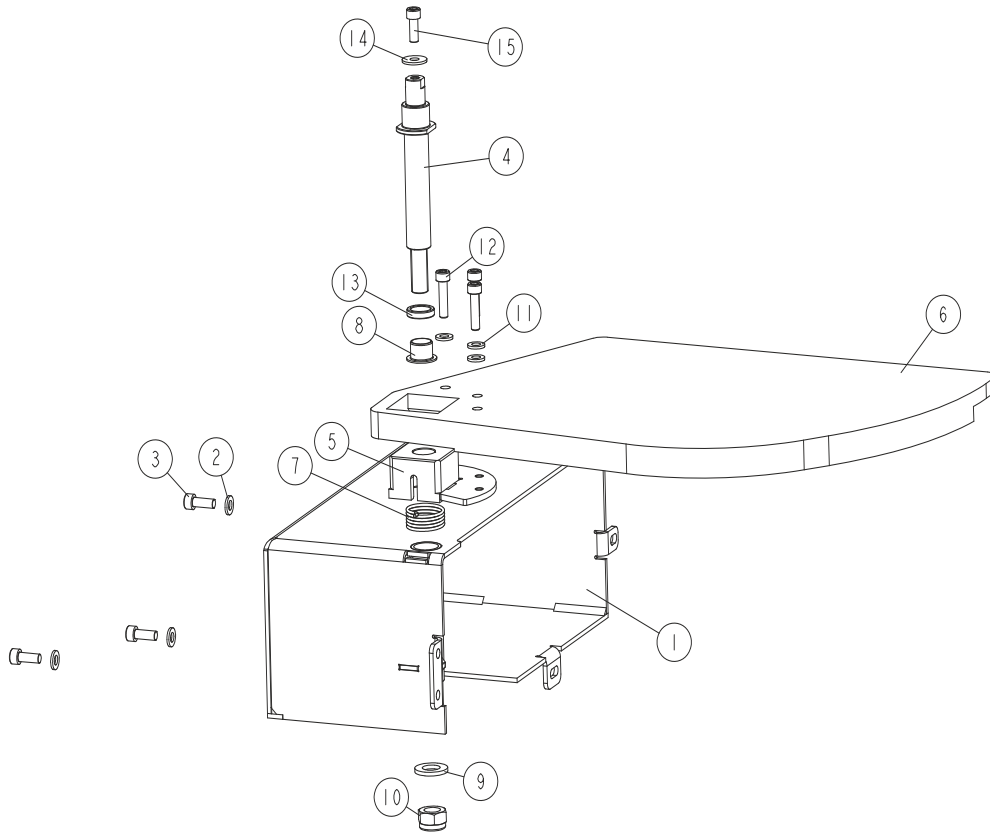

REF	DESCRIPTION (u indicates parts available in assemblies only)	PART #	QTY
-	<b>MP160 UL COVER <sup>1</sup></b>	570009	1
-	UL COVER - COMPLETE	569001	1
1	COVER - WELDMENT	569002-1	1
2	WASHER 6.4 FE/ZN5 PN-78/M-82005	F81053-1	3
3	SCREW, M6X16 8.8 HEX SOCKET HEAD CAP ZIN	F81001-21	3
-	CUTTER COVER	570019	1
4	PIVOT	570018-1	1
5	BUSHING, MOUNTING	569011-1	1
6	COVER, MOVABLE	568419	1
7	SPRING, TENSION	569012	1
8	BUSHING, SLIDE IGUS: JFM_1416_12_1	569013	1
9	WASHER,13 FLAT ZINC	F81056-1	1
10	NUT, M12 8 HEX NYLON ZINC LOCK	F81034-2	1
11	WASHER 6.4 FE/ZN5 PN-78/M-82005	F81053-1	3
12	SCREW, M6X25-8.8 HEX SOCKET HEAD CAP ZIN	F81001-41	3
13	BUSHING, DISTANCE	570020-1	1
14	WASHER, 6.5 SPECIAL FLAT ZINC	F81053-11	1
15	SCREW, M6X16 8.8 HEX SOCKET HEAD CAP ZIN	F81001-21	1

<sup>1</sup> American version only

### 3.8 Emergency stop switch assembly 535669

535669\_001\_A  
535669\_MANUAL

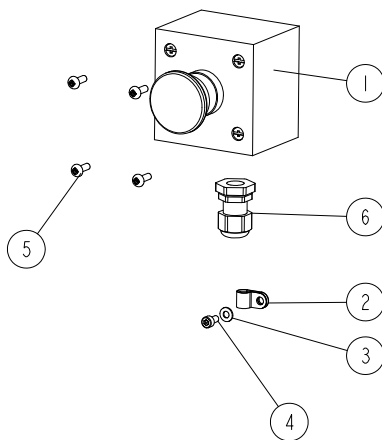

REF.	DESCRIPTION (* indicates parts available in assemblies only)	PART #	QTY
-	<b>SWITCH ASSEMBLY, MP160 EMERGENCY STOP</b>	535669	1
1	SWITCH, LPZ P1 B5 03 EMERGENCY STOP	536158	1
2	ELEMENT, EE63 MOUNTING	F81080-4	3
3	WASHER, 4.3 FLAT ZINC	F81051-2	3
4	SCREW, M4X8 8.8 HEX SOCKET HEAD CAP ZINC	F81011-36	3
5	SCREW, M4X12 -5,8-B CROSS RECESSED PAN HEAD ZINC	F81011-43	4
6	GLAND, DP 9/H CABLE	F81096-2	1