

user manual

Instrukcja obsługi | Руководство пользователя
Manuel de l'Utilisateur | Betriebsanweisung
Bruksanvisning | Manual del Usuario
Betjeningsvejledning | Gebruikershandleiding
Käyttöohjeet | Manual de utilizare | Bruksanvisning
Manuale d'uso | Příručka uživatele | Navodila
za uporabo

Retain for future use
Zachować do przyszłego użytku
Сохраните для последующего
использования
A conserver pour une utilisation future
Für zukünftige Benutzung aufbewahren
Behold for senere bruk
Säilytä nämä käyttöohjeet tulevaa tarvetta marten
Opbevar manualen til fremtidig brug
Bewaren voor gebruik in de toekomst
Conservare il presente manuale a l'uso futuro
Păstrați acest manual pentru utilizare viitoare
Conservar para futuras consultas
Behall för framtida användning
Uchovejte pro další použití
Hranite za prihodnjo uporabo

Wood-Mizer®

Safety, Setup, Operation and Maintenance

MF130 E3S

rev. A1.01



Safety is our #1 concern! Read and understand all safety information and instructions before operating, setting up or maintaining this machine.

Form #2502

Original Instructions

Please keep for future reference

Table of Contents	Section-Page
SECTION 1 INTRODUCTION	1-1
1.1 Machine Description	1-2
1.2 MF130 Moulder Major Components	1-6
SECTION 2 SAFETY	2-1
2.1 Safety Symbols.....	2-1
2.2 Safety Instructions	2-1
SECTION 3 SETUP	3-1
3.1 Optional XY Table Mounting	3-1
SECTION 4 OPERATION	4-1
4.1 Pre-Operation Check	4-1
4.2 MF130 Moulder Operation.....	4-3
SECTION 5 MAINTENANCE & ALIGNMENT	5-1
5.1 Wear life	5-1
5.2 Sawdust Removal	5-1
5.3 Miscellaneous Maintenance	5-1
5.4 Long-term storage	5-2
5.5 Safety Devices Inspection (Only CE Version).....	5-3
SECTION 6 MF130 SPECIFICATIONS	6-1
6.1 Overall dimensions.....	6-1
6.2 Specifications of the moulder.....	6-2
6.3 Dust/Chip Extractor Specifications	6-3

SECTION 1 INTRODUCTION

Congratulations on your purchase of a Wood-Mizer MF130 Moulder!

Wood-Mizer is committed to providing you with the latest technology, best quality, and strongest customer service available on the market today. We continually evaluate our customers' needs to ensure we are meeting current wood-processing demands. Your comments and suggestions are welcome.

This documentation includes information on preparing the Moulder for operation, servicing and repairing the machine.

GENERAL

Check your Moulder as soon as you receive it. Report any transport damage to the transport company immediately.

Lift the Moulder using a forklift or a pallet jack with lifting capacity of at least 500kg.

When replacing the spare parts, use only original parts and note that all electrical components must be assembled by a qualified electrician.

APPLICATIONS

The Moulder can be used for sawing wood, chipboard, fibreboard etc.

The machine is intended for indoor use.

REQUIREMENTS

The Moulder can be used in rooms with a temperature ranging from -15°C to +40°C. The ventilation must be mechanical and in accordance with standards.

The Moulder must be connected to a dust extractor. The dust extractor must be turned on when the machine is working.

SAFETY DISTANCE



WARNING! No one, except the operator, should be within 3 meters of The Moulder's sides or 4 meters from the infeed and outfeed sides during operation. Mark a limit to prevent anyone from accidentally entering the risk area.

STORAGE

The machine must be placed in a dry area, as it is not fully protected against corrosion. If the machine is placed in a cold area for an extended period of time, its unprotected components, such as tables or cutters, must be lubricated with a large amount of e.g. paraffin. It is also a good idea to cover the device for additional protection against corrosion. If the machine is supposed to be placed outdoors, its unprotected components must be covered and lubricated with anti-corrosive agents.

1.1 Machine Description

The MF130 is a solid precision Moulder with large capacity and a minimal footprint, making it ideal for any workshop. Its cast iron base and wide sliding table enables you to achieve high accuracy and comfort of work.

you can use the MF130 for straight moulding, curved moulding, routing, tenoning. The spindle can be raised or lowered, and with a tiltable range of 270 degrees, the cutter or router bit can machine the board from below, the sides and from above.

MACHINE AND SITE PREPARATION

The machine is delivered on a pallet. Due to the weight, it has to be transported with auxiliary carrier equipment and in accordance with the general safety rules.

Check your Moulder as soon as you receive it. Any transport damage must be reported to the transport company immediately.

Most of the machine is protected against rust, but it will require extra maintenance in the form of lubrication for all the parts that are not protected against rust. See the Maintenance section.

- Place the saw on a stable and flat base.
- It is recommended that the Moulder should be bolted to the ground (Bolt diameter 8-10 mm), if it does not have to be moved.
- Ensure that there is enough space for the longest boards you want to saw on the infeed and outfeed sides, and that there is enough space for maintenance and timber stocks.
- Connect the dust hoses and fix them using the hose clips on the Moulder and fan.
- Hang the electrical cable of the machine to the ceiling or protect it in another way. Never step on the cable. The Moulder should be connected via an earth-fault protection switch.
- CAUTION! The illuminance at the operator's position should be at least 300lx. The light source cannot cause the stroboscopic effect. Ensure that there is no risk of glare.

SPACE REQUIREMENTS

See Figure 1-1

The Moulder needs a space of at least 4 m (13') wide.

The required length depends on the length of workpieces you want to saw. The minimum length is 4 m (13') from the front and from the end of the machine.

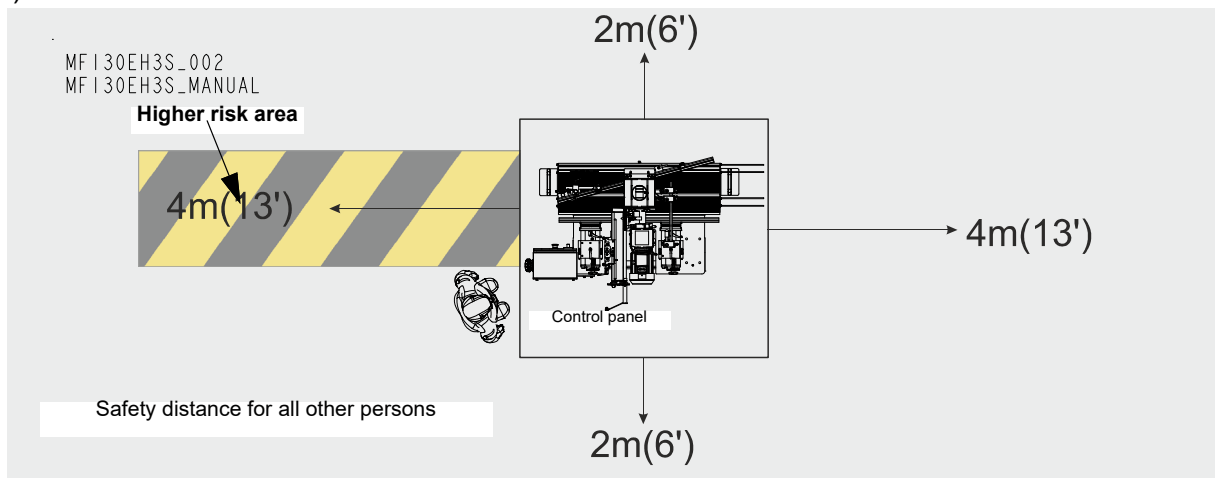

FIG. 1-1

ANCHORING

For the highest safety, the Moulder must be anchored to the floor with 8-10 mm diameter anchor bolts.

TOOLS REQUIRED TO USE THE MOULDER:

- Wrench 30 mm (supplied)
- Wrench 17 mm
- Allen wrench 3 mm
- Allen wrench 4 mm
- Allen wrench 5 mm
- Allen wrench 6 mm
- Allen wrench 8 mm
- Allen wrench 10 mm
- Sliding calliper
- Measuring tape
- Oil Can (paraffin oil for tables)
- Whetstone
- Pusher (enclosed)

SPACER RINGS THAT ARE SUPPLIED:

- 3 x 40 mm height (per cutter)
- 2 x 20 mm height (per cutter)
- 2 x 10 mm height (per cutter)
- 1 x 5 mm height (per cutter)
- 1 x 2 mm height (per cutter)
- 1 x 1 mm height (per cutter)
- 1 x 0.5 mm height (per cutter)
- 1 x 0.3 mm height (per cutter)
- 1 x 0.2 mm height (per cutter)
- 1 x 0.1 mm height (per cutter)

These spacer rings are necessary to set the required height.

CHIP EXTRACTOR

The MF130 Moulder must be connected to a chip extractor with a total capacity of at least 1000m³/h. Remember that the chip container has to be equipped with an air vent (e.g. a fine net or filter if dust is collected indoors). Poor suction is often caused by poor airflow from the chip container. During work in heated rooms, it is necessary to remember that the fan will quickly cool the space if the filtered air is not supplied back into the building. The fire risk and dust emissions (discharge) must be considered because of chip collection.



WARNING! There is a risk of fire and dust emission because of chip collection.

Contact the local authorities for advice about designing the chip collection system to conform to the national rules.

It is necessary to set the fan so that it is easy to reach the switch.



IMPORTANT! Remove the chips from the Moulder when the work is finished.

TECHNICAL REQUIREMENTS FOR THE CHIP EXTRACTOR¹

1. EN 12779:2016-04 standard contains requirements for chip and dust extraction systems equipment with fixed installations.

- The chip extractor must be approved according to the CE standard.
- The chip extractor hose diameters for the Moulder = 100 mm (4”).
- The pressure drop in the Moulder is 20 mm column of water at 25 m/s.
- The dust extractor airflow (“without external connection”) should be 1000 m³/h.



IMPORTANT! The dust extractor hoses must be grounded or made of materials that do not accumulate an electrostatic charge.



CAUTION! Always turn on the chip extractor before starting the machine.

1.2 MF130 Moulder Major Components

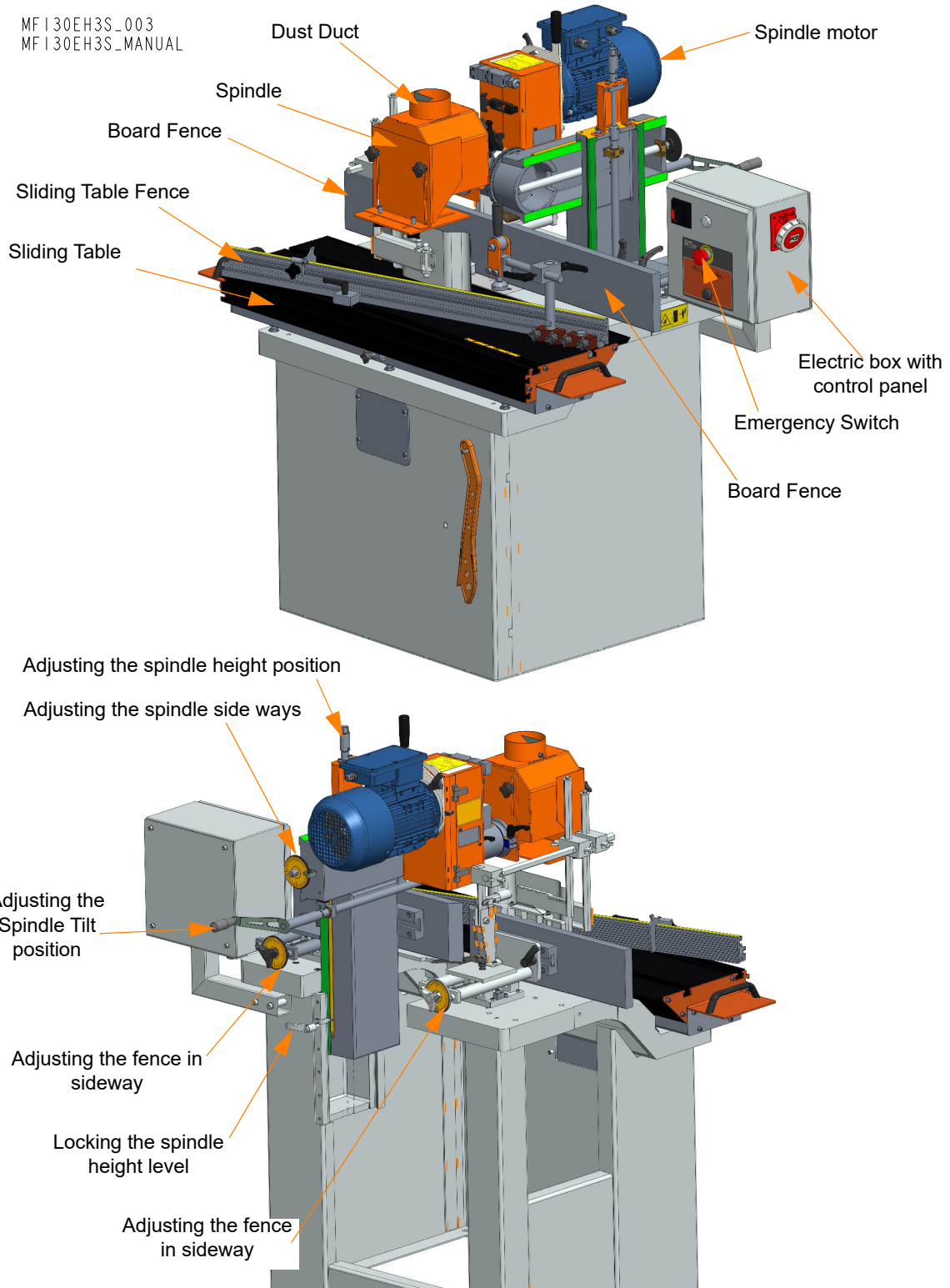



FIG. 1-2 MF130

SECTION 2 SAFETY

2.1 Safety Symbols

The following symbols and signal words call your attention to instructions concerning your personal safety. Be sure to observe and follow these instructions.

 **DANGER!** indicates an imminently hazardous situation which, if not avoided, will result in death or serious injury.

 **WARNING** suggests a potentially hazardous situation which, if not avoided, could result in death or serious injury.

 **CAUTION!** refers to potentially hazardous situations which, if not avoided, may result in minor or moderate injury or damage to equipment.

 **IMPORTANT!** indicates vital information.

NOTE: gives helpful information.

 Warning stripes are placed on areas where a single decal would be insufficient. To avoid serious injury, keep out of the path of any equipment marked with warning stripes.

2.2 Safety Instructions

NOTE: ONLY safety instructions regarding personal injury are listed in this section. Caution statements regarding machine damage appear where applicable throughout the manual.

- Observe safety instructions.

 **IMPORTANT!** Read the entire Operator's Manual before operating the Moulder. Take notice of all safety warnings throughout this manual and those posted on the equipment. Keep this manual with this equipment at all times, regardless of ownership.

Read all additional manufacturer's manuals and observe any applicable safety instructions including dangers, warnings, and cautions!

IMPORTANT! Only adult persons who have read and understood the entire operator's manual should operate the Moulder. The machine is not intended for use by or around children. Never operate the Moulder under the influence of alcohol or drugs.

IMPORTANT! The operator of the Moulder should get adequate training in the operation and adjustment of the machine.

IMPORTANT! It is always the owner's responsibility to comply with all applicable federal, state and local laws, rules and regulations regarding the ownership and operation of your Wood-Mizer Moulder. All Wood-Mizer Moulder owners are encouraged to become thoroughly familiar with these applicable laws and comply with them fully while using the machine.



- Wear safety clothing.



WARNING! Secure all loose clothing and jewelry before operating this machine. Failure to do so may result in serious injury or death.

WARNING! Always wear gloves and eye protection when handling blades. Changing blades is safest when done by one person! Keep all other persons away from area when carrying or changing a blade. Failure to do so may result in serious injury.

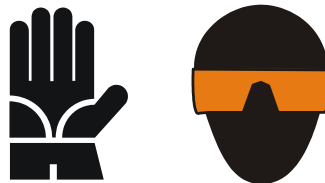

WARNING! Always wear protective gloves (compatible with EN 388, Category III) and protective apron (compatible with EN ISO 13688:2013-12, kategorie I) when operating the machine.

WARNING! Always wear ear, respiration, hand and foot protection when operating the Moulder.



- Keep the machine and area around clean.



DANGER! Maintain a clean and clear path for all necessary movement around the Moulder and lumber stacking areas. Failure to do so will result in serious injury.

- Dispose of sawing by-products properly.



IMPORTANT! Always properly dispose of all sawing by-products, including sawdust and other debris.

CAUTION! The work-stand of the Moulder should be equipped with a 4 kg or bigger dry powder extinguisher.

- Check the Moulder before operation.



DANGER! Make sure all guards and covers are in place and secured before operating the Moulder. Check that all handles, screws, nuts, tailstocks, sleeves, saw blades etc. are properly tightened. Check that the saw blade can rotate freely and that there are no tools in or on the machine before it is started. Failure to do so may result in serious injury.



WARNING! Always shut off the motor to stop the cutter whenever the Moulder is not in use. Failure to do so may result in serious injury.

WARNING! Do not for any reason adjust the motor drive belts with the motor running. Failure to do so will result in serious injury.

- Keep all people away.



DANGER! No one, except the operator, should be within 4 meters of

the Moulder sides during operation. Failure to do so will result in serious injury.

- Keep hands away.

DANGER! Moving parts can cut or crush fingers or hand. Keep hands clear. Make sure all guards and covers are in place and secured before operating the Moulder. Failure to do so may result in serious injury.

DANGER! Always be aware of and take proper protective measures against rotating shafts, pulleys, fans, etc. Always stay a safe distance from rotating members and make sure that loose clothing or long hair do not engage rotating members resulting in possible injury.

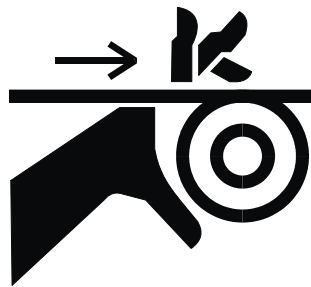



WARNING! Beware of rotating parts. Shut down the machine and allow all moving parts to come to a complete stop before removing any guards and covers. Do NOT operate the Moulder with any guards or covers removed.

WARNING! Kickback hazard. Stay clear of area during operation. Follow all anti-kickback service and safety rules. Failure to do so may result in serious injury.



Moulder Operation

 **CAUTION!** The workplace should always be well illuminated. The illuminance at the operator's position should be at least 300lx. Never use the Moulder under the influence of strong medication, alcohol or drugs.

 **IMPORTANT!** When starting the machine for the first time, check that the main motor rotation direction is as indicated by the arrow located on the motor body (fan guard). If the rotation direction is incorrect, invert the phases in the phase inverter in the power socket (electrical box). Setting the phases in the phase inverter correctly will ensure correct rotation directions of all motors.

- Use proper maintenance procedures.

 **DANGER!** Make sure all electrical installation, service and/or maintenance work is performed by a qualified electrician and in accordance with applicable electrical codes.

DANGER! Hazardous voltage inside the electric boxes and at the motor can cause shock, burns, or death. Disconnect and lock out power supply before servicing! Keep all electrical component covers closed and securely fastened during machine operation.



 **WARNING!** Consider all electrical circuits energized and dangerous.

WARNING! Never assume or take the word of another person that the power is off; check it out and lock it out.

WARNING! Do not wear rings, watches, or other jewelry while working around an open electrical circuit.



IMPORTANT! The Moulder is equipped with an emergency stop button. It is used to immediately stop the motor in case of emergency. The emergency stop button should always be in good condition.

IMPORTANT! The Moulder should not be modified by the owner. Use only original spare parts.

IMPORTANT! Limit switch should be always in proper working condition.

- Keep safety labels in good condition.



IMPORTANT! Always be sure that all safety decals are clean and readable. Replace all damaged safety decals to prevent personal injury or damage to the equipment. Contact your local distributor or Wood-Mizer Customer Service to order more decals.

IMPORTANT! If replacing a component which has a safety decal affixed to it, make sure the new component also has the safety decal affixed in the same place.

- Fire protection

CAUTION! The work-stand of the Moulder should be equipped with a 4 kg or bigger dry powder extinguisher.

Safety Labels Description

See the table below for safety labels description.

TABLE 2-0

Label View	Label Number	Description
	096317	CAUTION! Carefully read the operator's manual before operating the machine. Observe all instructions and safety rules when operating.
	096316	Electric box opening is possible with the switch in "0" position only.
	096319	Always disconnect the power cord before opening the electric box.

TABLE 2-0



	<p>099221H</p>	<p>CAUTION! Keep safe distance when the machine is working.</p>
	<p>524993</p>	<p>CAUTION! Hand injury hazard</p>
	<p>535402</p>	<p>Always wear safety goggles, boots, gloves and ear muffs when operating the machine !</p>

TABLE 2-0

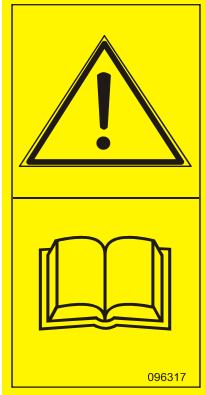
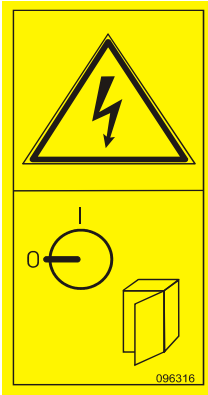
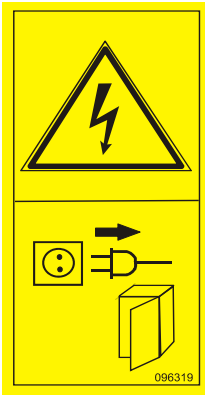
	<p>S20097</p>	<p>Motor rotation direction</p>
	<p>P85070</p>	<p>CE safety certification</p>

SECTION 3 SETUP

Some of the machine components need to be assembled by the user before the first usage.

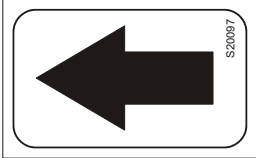
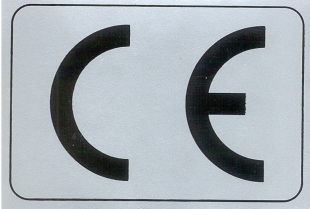
To view the exact type and dimensions of the fasteners please see MF130 Parts List (#2503)

3.1 Optional XY Table Mounting

1. Before installing the XY table, unscrew the cross knob (A). To lock the table after mounting, use an M8 screw.
2. Slide the handles (B) into the Sliding Table.
3. Put the Angle (C) under the Sliding Table between two nuts. Tighten the nuts to stabilize the Angle.

See Figure 3-1.

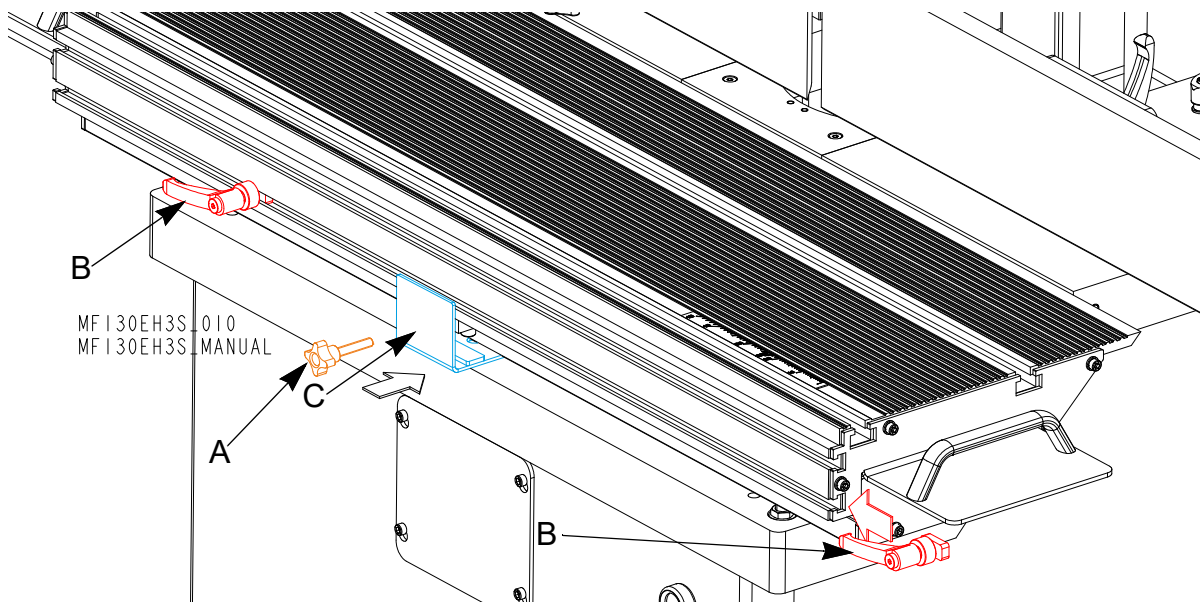

FIG. 3-1

See Figure 3-2.

4. Slide the mounting plates (A) and the mounting plate of the handle's rod stopper (C) into the Sliding Table.

See Figure 3-3.

5. Set the plates (A) that they are evenly spaced between axis of the spindle (D)

6. Tighten the mounting plates using the fasteners (B).

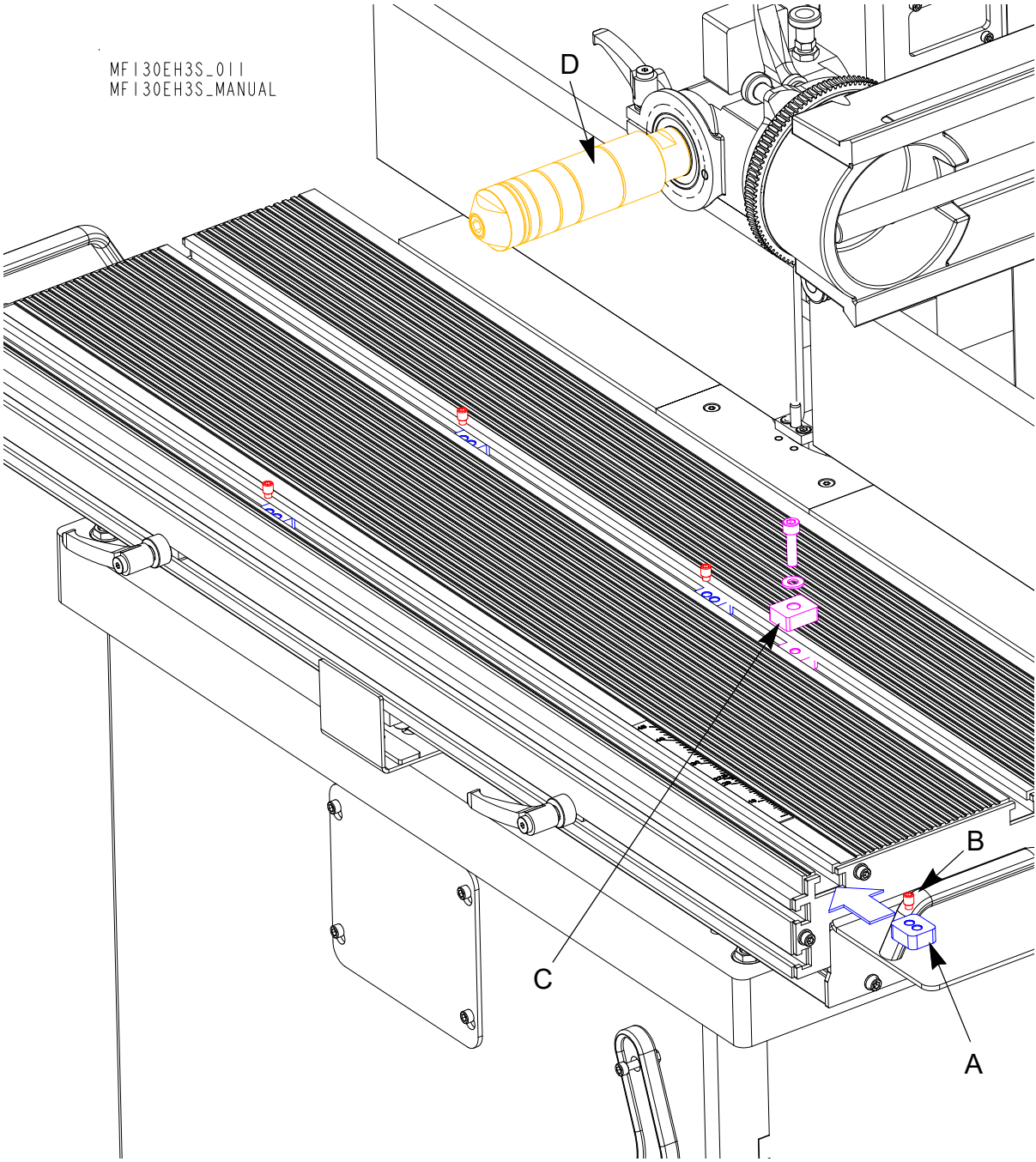

FIG. 3-2

3

SETUP

Optional XY Table Mounting

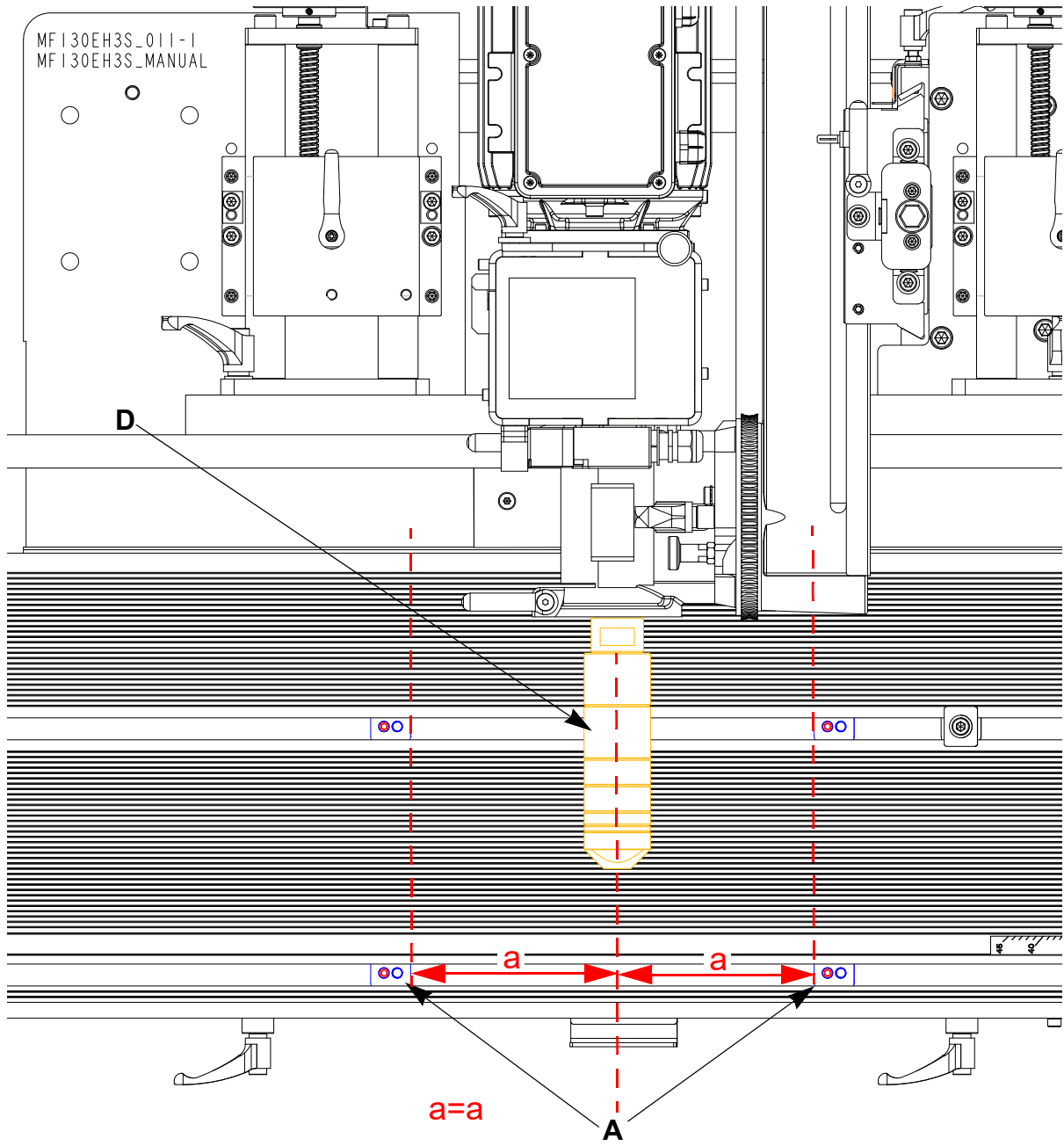

FIG. 3-3

See Figure 3-4.

7. Put the Main Working Plate (A) on the mounting plates (B).

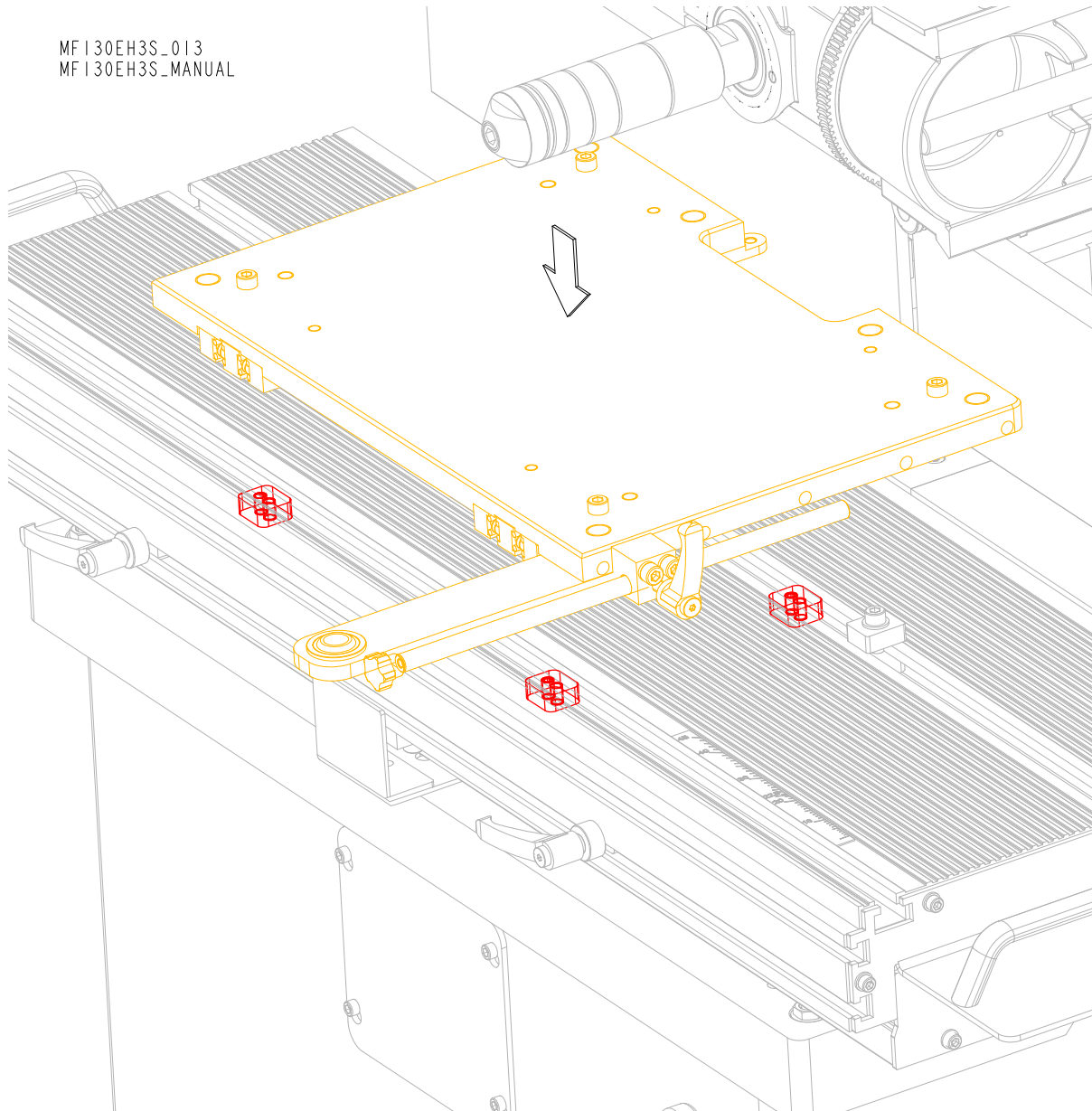

FIG. 3-4

See Figure 3-5.

3

SETUP

Optional XY Table Mounting

- Slide the Main Working Plate to insert Bolts into the mounting plates.

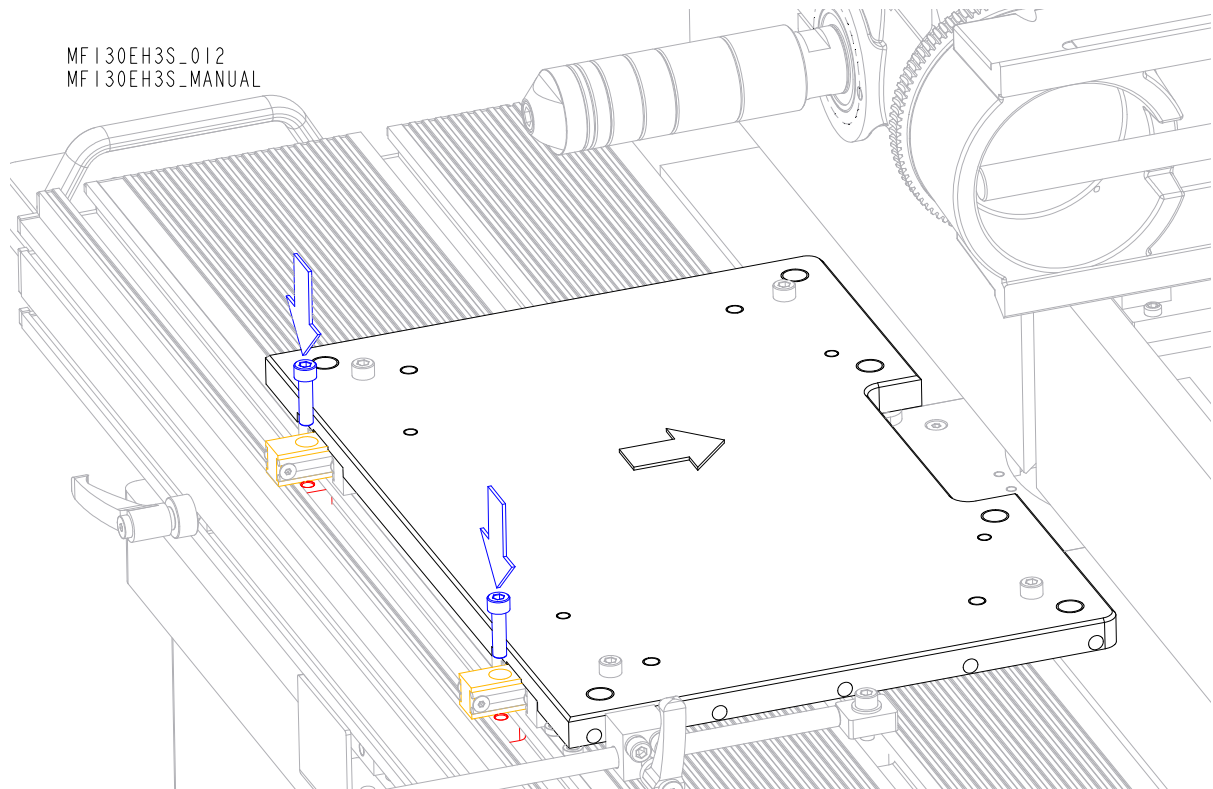

FIG. 3-5

See Figure 3-6.

9. Slide the Main Working Plate to the other side to insert Bolts into the mounting plates.

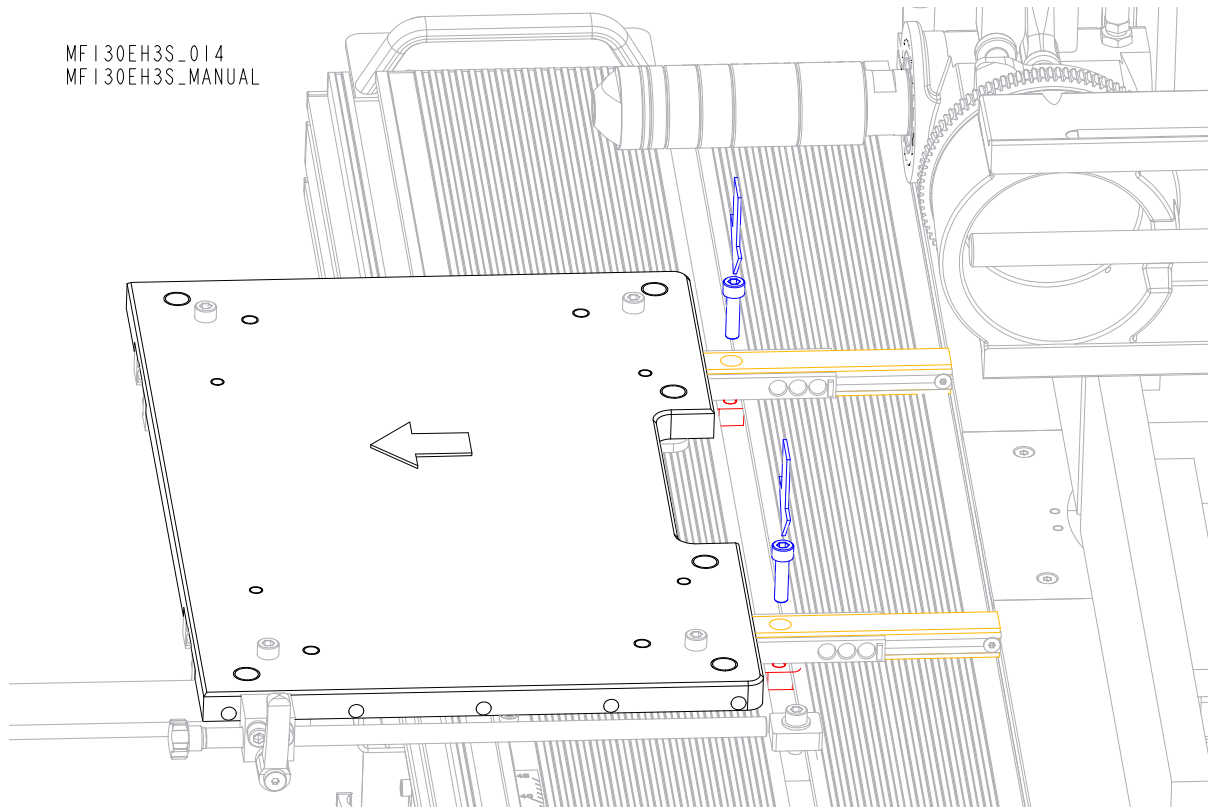

FIG. 3-6

See Figure 3-7.

10. Mount the Bottom Pin Bracket.

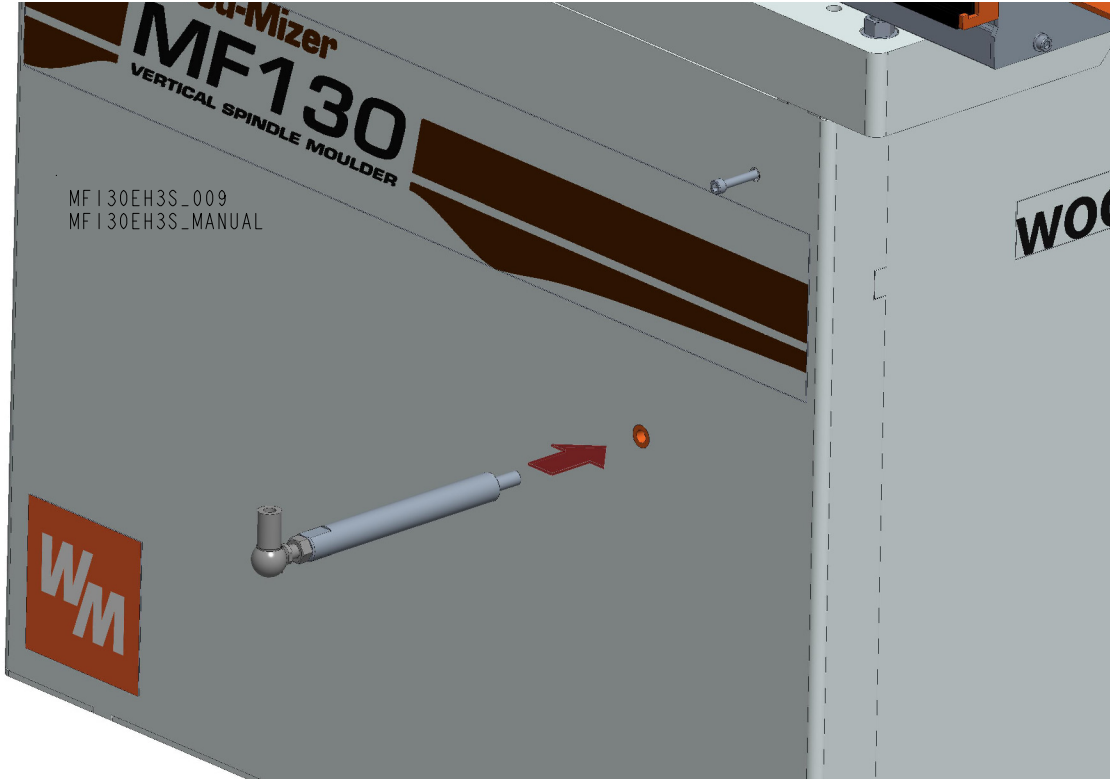

FIG. 3-7

See Figure 3-8.

11. Mount the Rod (A) into the Bottom Pin Bracket (B) through the Bearing (C).

MF130EH3S_015
MF130EH3S_MANUAL

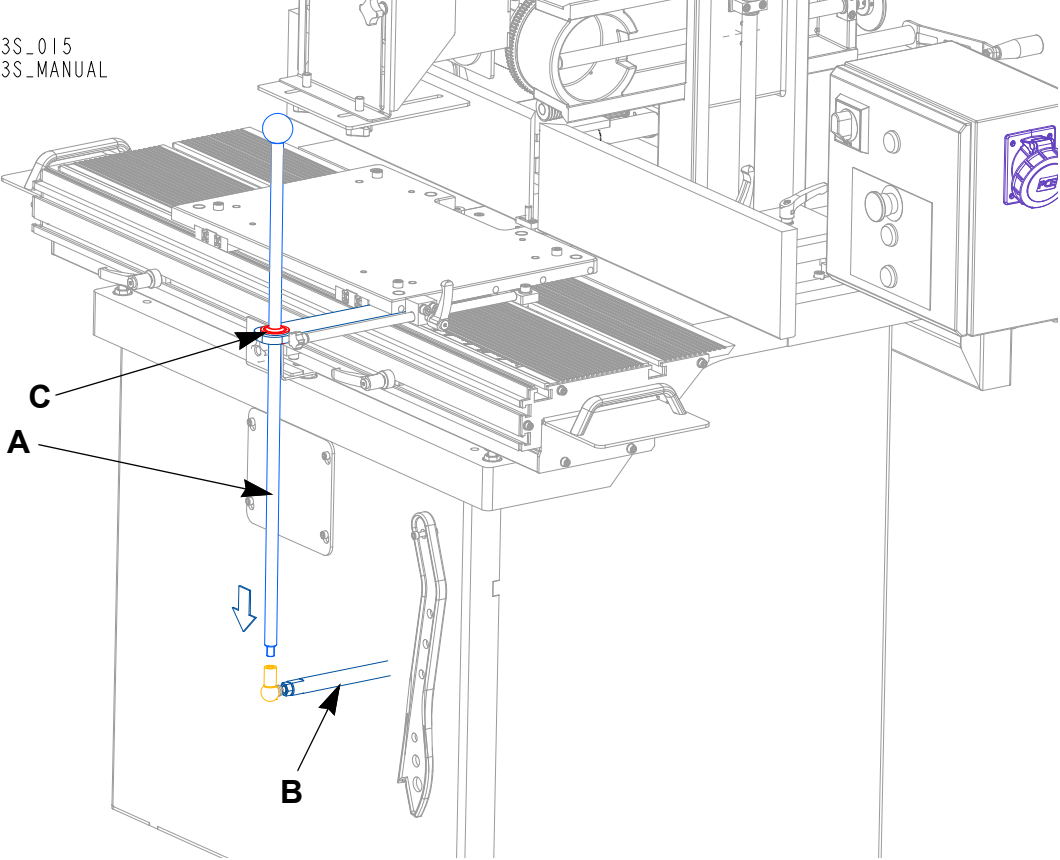

FIG. 3-8

SECTION 4 OPERATION

4.1 Pre-Operation Check



IMPORTANT! Before starting to use the MF130 Moulder you have to meet the following conditions:

- Set up the MF130 Moulder on firm, level ground and level the machine. Secure the machine to the ground to prevent moving during operation. A cement pad with 8-10 mm diameter anchor bolts is recommended.
- The MF130 Moulder can be operated indoors with the sawdust collection system only.
- The MF130 Moulder must not be operated when it is raining/snowing and in case of rain or snow the machine must be stored under roof or indoors.
- The MF130 Moulder can be operated in temperatures ranging from -15°C to +40°C only.
- The illuminance at the operator's position should be at least 300 lx¹.
- The operator's position and E-Stop button location are shown below.

See Figure 4-1.

MF130EH3S_006
MF130EH3S_MANUAL

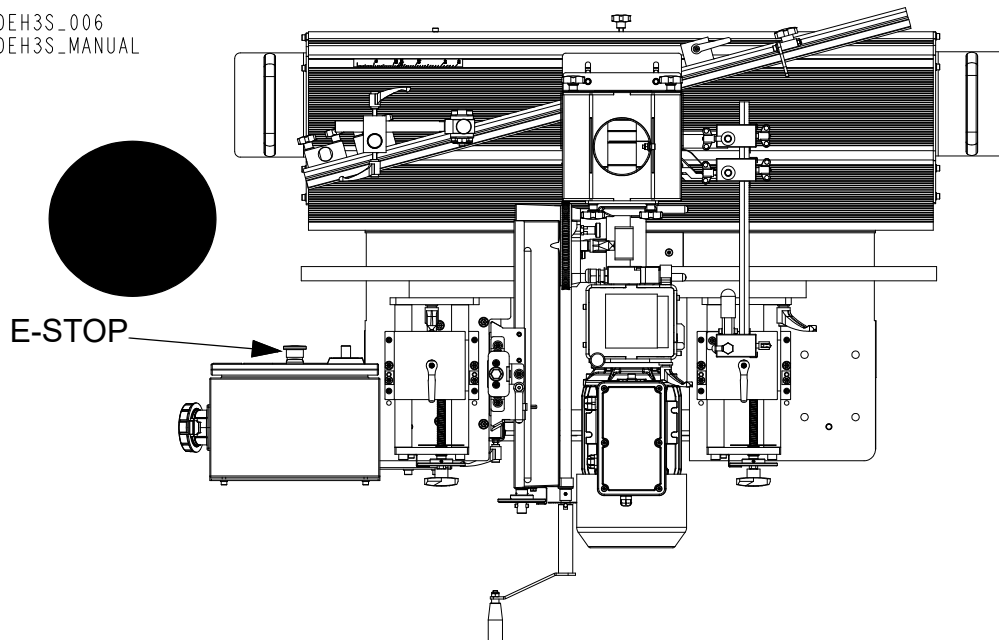

FIG. 4-1

See table 4-1. Have a qualified electrician install the power supply (according to EN 60204

1. The light source must not cause the stroboscopic effect.

Standard). The power supply must meet the specifications given below.

3-Phase Volts	Fused Disconnect Switch	Suggested Wire Size
400 VAC	16 A	1.5 mm ² Max. length: 15 m

TABLE 4-1



IMPORTANT! It is recommended that a 30mA GFI (Ground Fault Interrupter) be used.



IMPORTANT! When starting the machine for the first time, check that the main motor rotation. If the rotation direction is incorrect, invert the phases in the phase inverter in the power socket (electrical box). Setting the phases in the phase inverter correctly will ensure correct rotation directions of the main motor and the blade.



WARNING! If the drive belt breaks, wait until all rotating parts are completely stopped. Failure to do so may result in serious injury or death.

- Check if no tools have been left in the machine.
- Check if the cutter can rotate freely.
- Review the safety instructions!
- Make sure the emergency stop button is released.
- Make sure the side cover is closed. Be sure all the parts of the machine are tightened, especially the cover of the working element.
- Make sure that no one apart from the operator is in the high risk area.
- Turn on the chip extractor.



DANGER! Connect the Moulder electrical installation. Check the rotational direction.

4.2 MF130 Moulder Operation

4.2.1 Control Panel

See **Figure 4-2**. The MF130 Moulder controls are shown below.

MF130EH3S_007
MF130EH3S_MANUAL

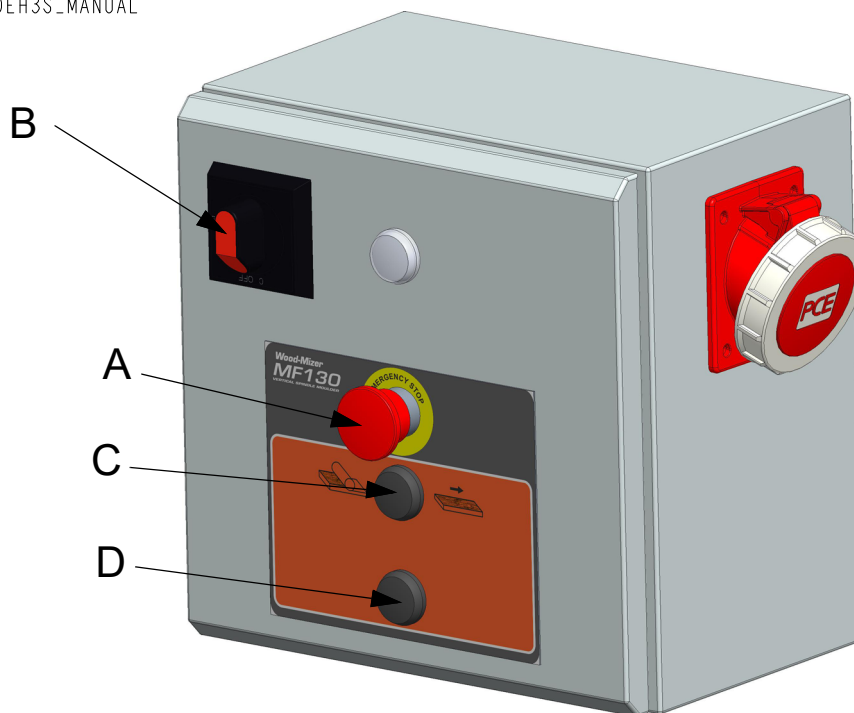

FIG. 4-2

- The red button (A) - the emergency stop button which disconnects power to all functions. When it is pressed, it must be released before restarting the Moulder (turn right).
- Main Switch (B). To turn the power on - switch to "I" (On) position. To turn the power off - switch to "0" (Off) position.
- The button (C) starts the main motor.
- The button (D) stops the blade motor.

4.2.2 Guide

ADJUSTING OF THE GUIDE

To adjust the guide parallel to the table, follow the steps below:

- Loosen the screws (A) holding the two carriage base plates (B).

See Figure 4-3.

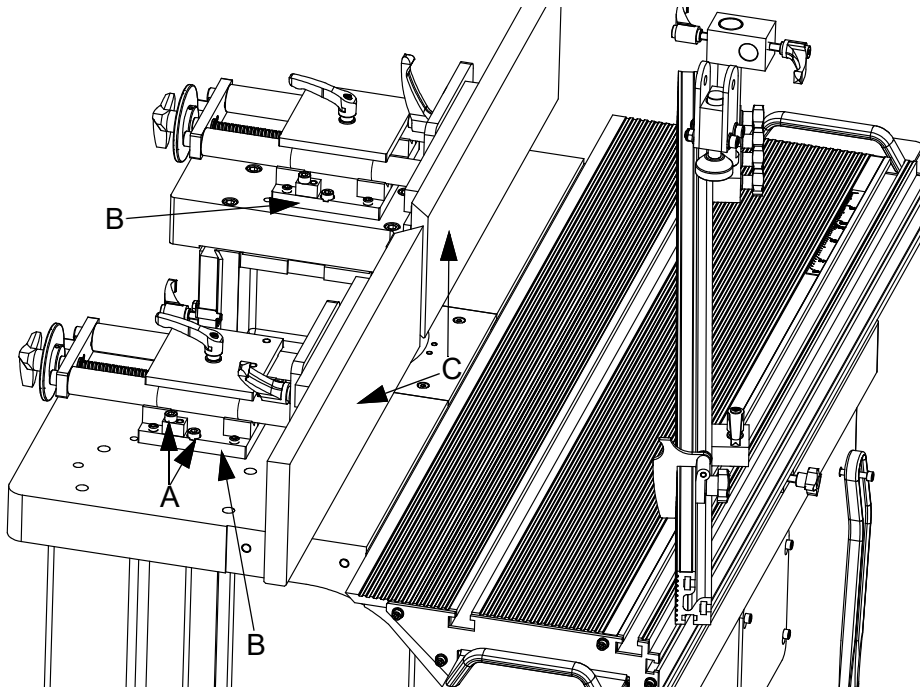

FIG. 4-3

- Attach the ruler (or board) longer than the guide to the guide (C) and tighten it with clamps. The clamps should press the ruler against the guide and the table, which will result in a straight position of the guide.
- Strongly tighten the screws mentioned in step one, remove the clamps and ruler.

To adjust the guide perpendicular to the table, follow the steps below:

- Loosen the screws (D) holding the two carriage base plates (B).

See Figure 4-4.

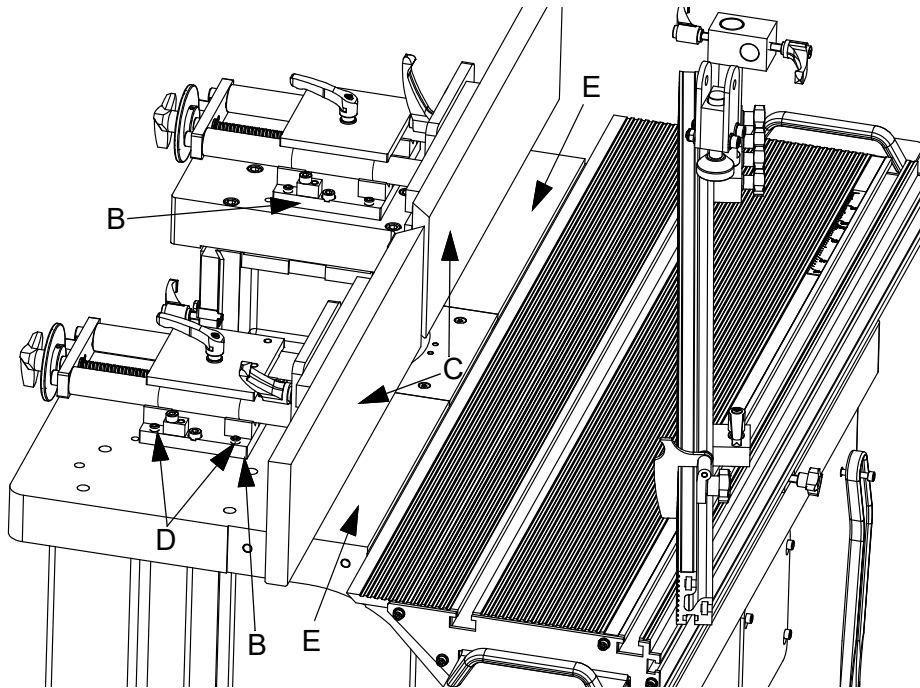

FIG. 4-4

- Position the guide (C) perpendicular to the main table (E) using a square.
- Strongly tighten the screws mentioned in step one.

4.2.3 Cutter



DANGER! Always be aware of and take proper protective measures against rotating shafts, pulleys, fans, etc. Always stay a safe distance from rotating members and make sure that loose clothing or long hair does not engage rotating members resulting in possible injury.



WARNING! Make sure the tools installed in the additional cutter are properly fastened before starting the motor.



IMPORTANT! When starting the machine for the first time, check that cutter rotation direction is as indicated by the arrow located on the side cover. If the rotation direction is incorrect, invert the phases in the phase inverter in the power socket (electric box). Setting the phases in the phase inverter correctly will ensure correct rotation directions of cutter. It is allowed to use the machine only if all cutters are rotating in the direction opposite to the feed direction.



IMPORTANT! Tools and shaft mounted in the additional cutter must be rated to work with speed up to 14.000 r.p.m.

Additional cutter can be used for fine planing, moulding, profiling at various angles, brushing and grinding.

ADJUSTING OF THE ADDITIONAL CUTTER.

Function description of the handles and cranks.

A - Cutter tilting crank. One full revolution of the crank tilts the cutter by $3,6^{\circ}$

B- Cutter tilting lock handle. Must be loosen before tilting the cutter.

C - Cutter tilting lock. Must be released before tilting the cutter.

D - Cutter height crank. Use a 17mm wrench to adjust.

E - Cutter height lock handle. Must be loosen before moving the cutter up or down.

F - Cutter left-right crank. One full revolution of the crank moves the cutter left or right by 4mm.

G - Digital angle meter.

H - Cutter drive belts tension handle.

I - Drive belt tension locking handle.

J - Cutter left-right lock handle. Must be loosen before moving the cutter left or right.

See Figure 4-5.

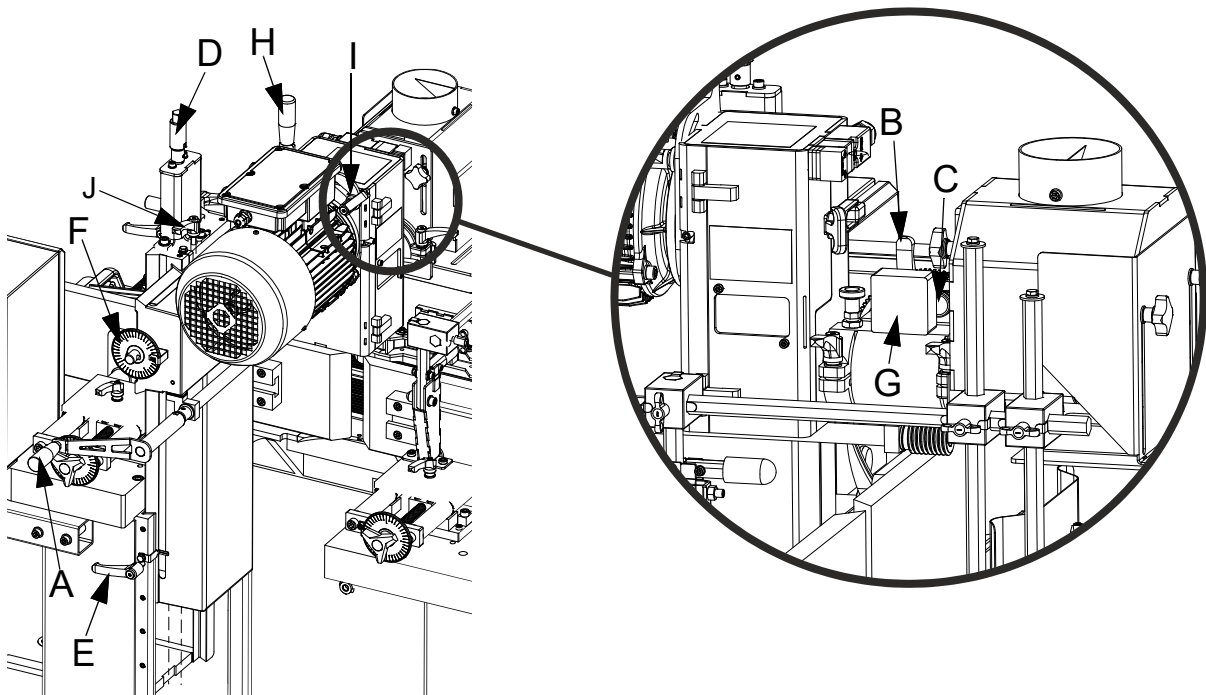

FIG. 4-5

TOOLS MOUNTING

Mount desired tool. To do this, hold the spindle in place (A) or (B) using 30mm wrench and loosen the spindle screw (C) using 10mm allen key. Replace one or more spacers with the cutter or sleeve of the same dimension. Mount desired tool in the cutter or sleeve and fasten it properly.

See Figure 4-6.

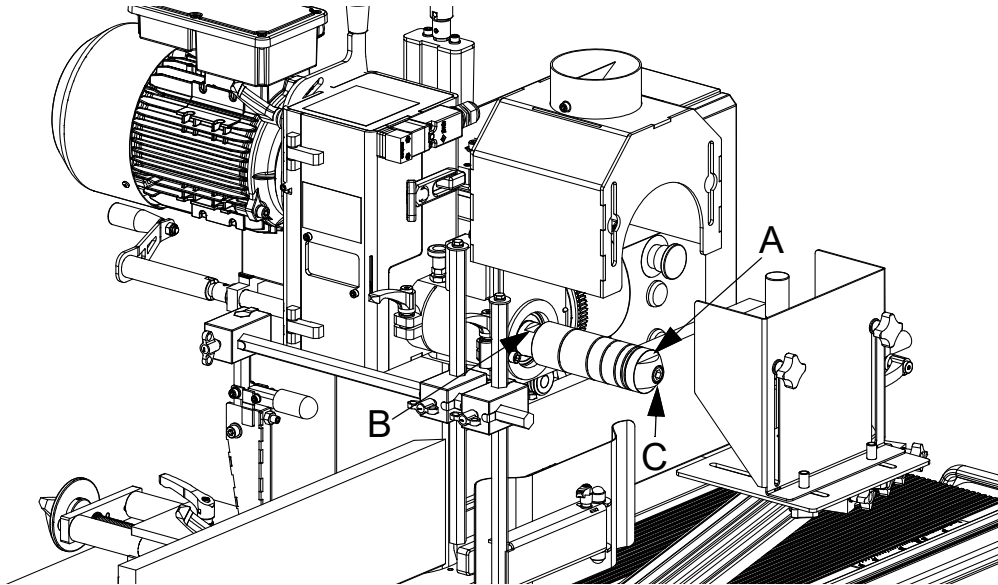

FIG. 4-6

CHANGING THE CUTTER RPM

! DANGER! Before performing any service to planer/moulder, disconnect the power cord from the electric box.

! WARNING! In case of a drive belt break, wait until all rotating parts are completely stop. Failure to do so may result in serious injury or death.

- Release the rubber latch (A) and open the drive belt housing (B).

See Figure 4-7.

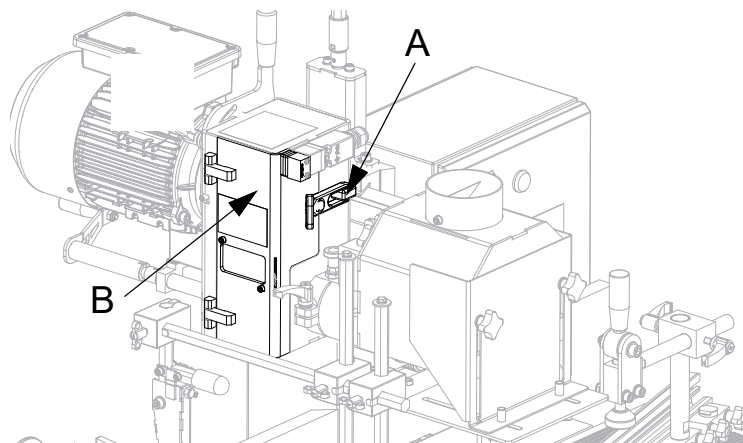

FIG. 4-7

- Release belt tension by loosening the locking handle (A).

See Figure 4-8.

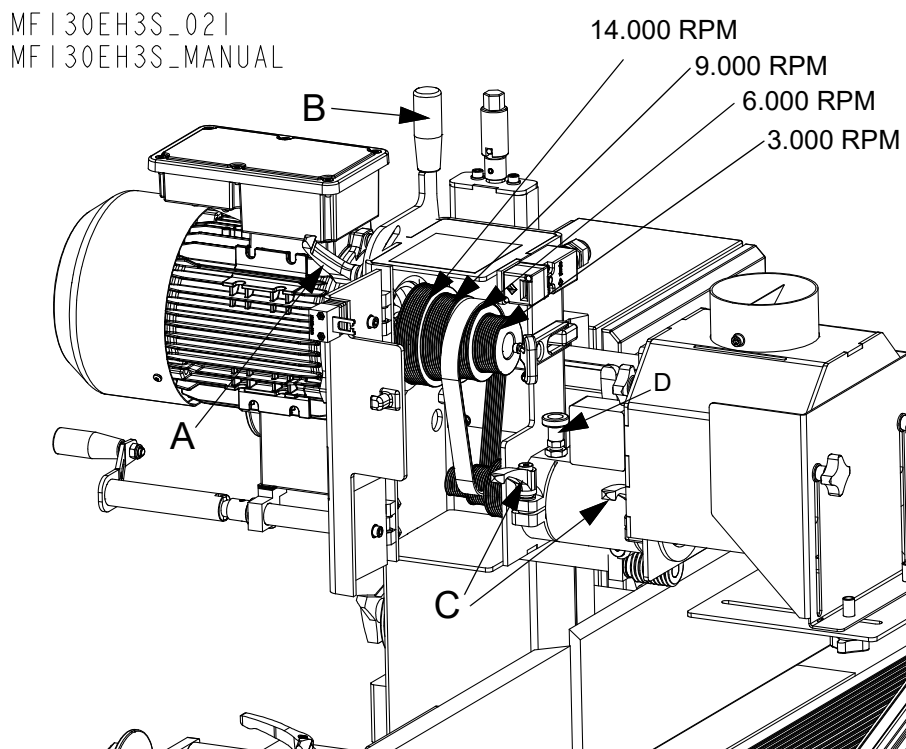

FIG. 4-8

- Change the position of the belt on the pulleys to set the cutter RPM. Double check if the tool mounted in the cutter is approved to work with RPM you want to set. The highest RPM (14.000) can be achieved with optional cutter spindle. To replace the spindle loosen both locking handles (C) and pull out the locking pin (D). After replacing the spindle, secure it with locking pin and tighten locking handles.

See Figure 4-9.

- Pull the handle (B) to tension the drive belt.

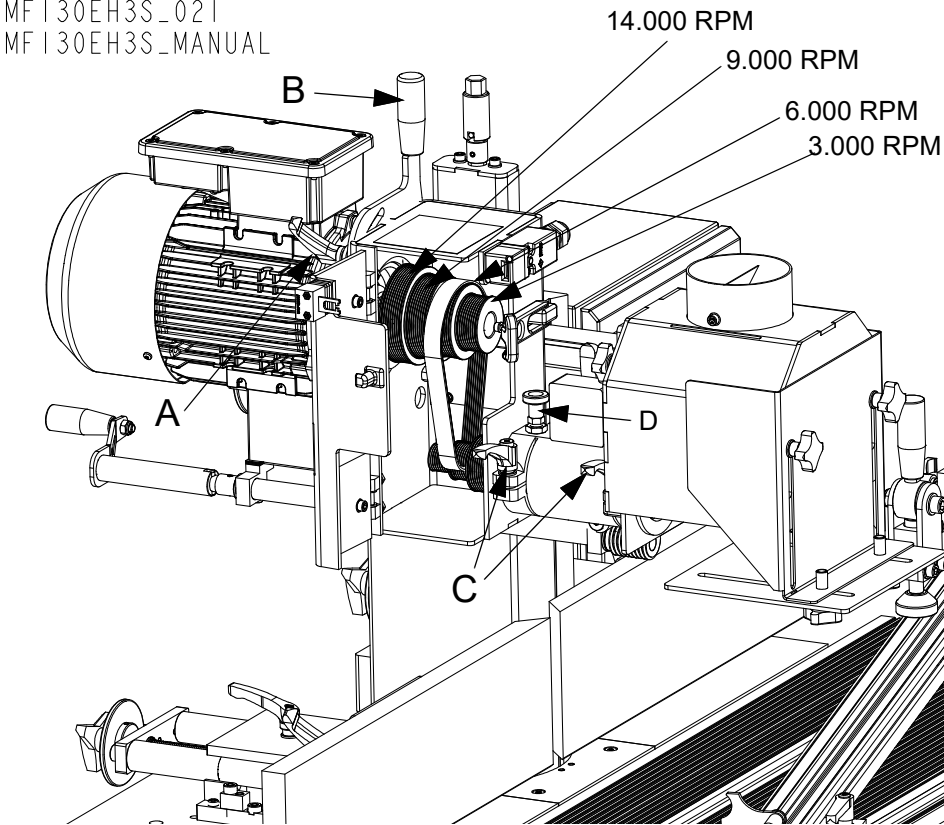

FIG. 4-9

See Figure 4-10.

- Adjust the belt tension to approximately 5 mm with 5 kg of deflection force.

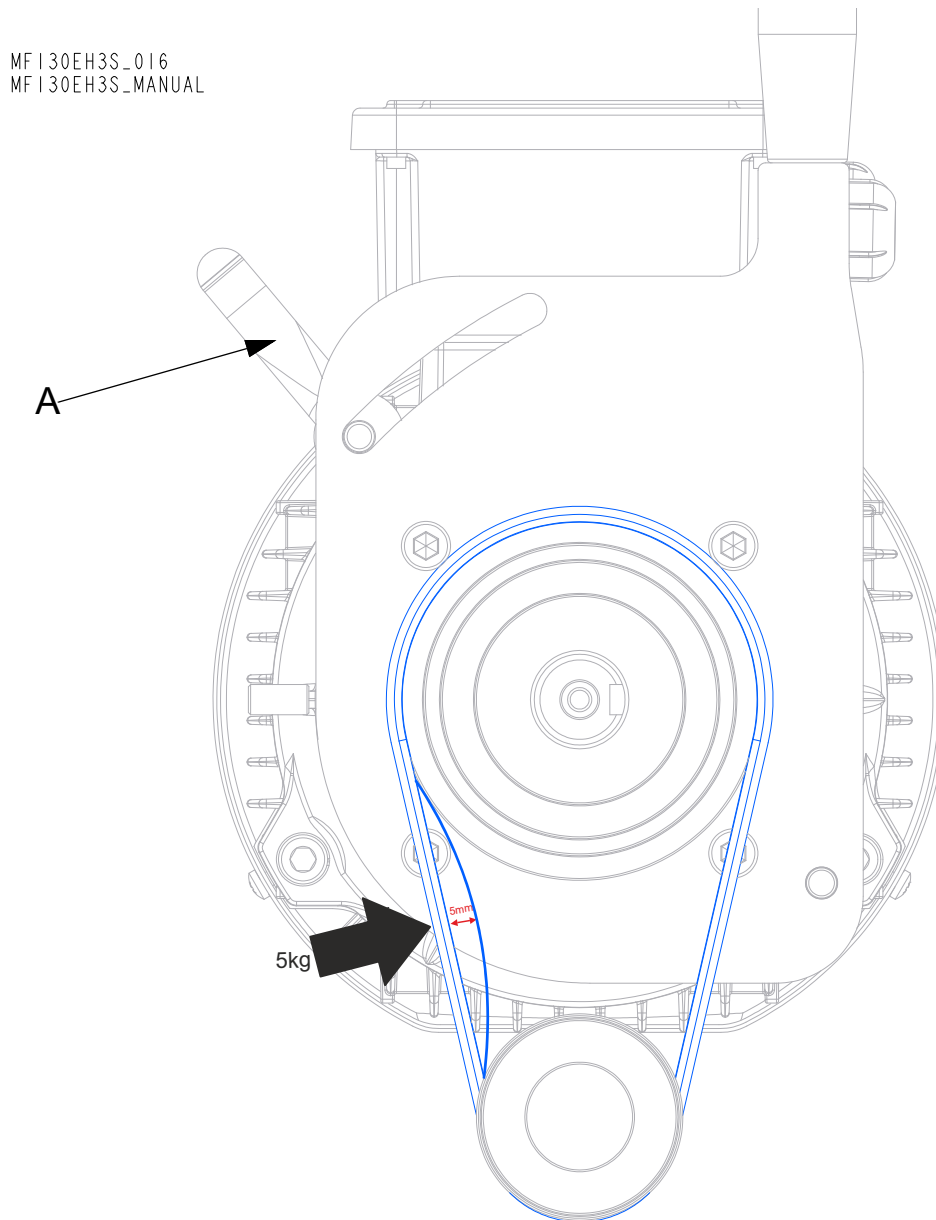

FIG. 4-10

- Lock the tensioner handle using locking handle (A)

SECTION 5 MAINTENANCE & ALIGNMENT

This section lists the maintenance procedures that need to be performed.

To view exact type and dimensions of the fasteners please see MF130 Parts List (#2503).



This symbol identifies the interval (hours of operation duty) at which each maintenance procedure should be performed.



CAUTION! Always disconnect and lock out power supply before performing any maintenance work, cleaning or servicing the Table Saw. Failure to do so may result in serious injury.



WARNING! Before performing service near moving parts such as blade, pulleys, motor, belt, set the main switch in the "0" position and disconnect the power cord.



WARNING! Always shut off the motor and allow all moving parts to come to a complete stop before removing any guards or covers. Do NOT operate with any guards or covers removed.

5.1 Wear life

See Table. 5-1. Estimated life expectancy of common replacement parts is given in table below. This information is provided so that you may plan ahead in ordering replacement parts. This chart lists estimated life expectancy of common replacement parts if proper maintenance and operation procedures are followed. Due to many variables which exist during machine operation, actual part life may vary significantly.

Part description	Estimated life
Drive belt	1250 hours

TABLE. 5-1

5.2 Sawdust Removal



Remove the excess sawdust and chips from the inside and outside of the Table Saw using compressed air and a brush every eight hours of operation.

5.3 Miscellaneous Maintenance

1. Clean resin from the table. Use solvent if necessary. Lubricate the table e.g. with mineral/paraffin oil.

2. Regularly check all the cables and connections and ensure that the motor compartment is kept free from shavings so that the motor fan receives cooling air.

3. Lubricate these parts every 50 hours:

50

- The thread spindles and their bearings.
- Guide ways on vertical arm and horizontal arm.
- Worm gear on tilting center.
- Guide ways on the fences
- Spindle (at an angle) and its bearings

4. Every 50 hours check if all screws and bolt connections are tightened. Check that cables and electrical connectors are in good condition.

50

5.4 Long-term storage

If the machine is not used for a long period of time, do as follows:

- Disconnect the power cord.
- Perform all routine actions described above.
- Loosen the motor belt tension.
- Spray a thin layer of anti-rust coating (such as P.D.R.P) onto the places not protected against rusting.
- Store the machine in a well ventilated room.
- Cover the Table Saw.

5.5 Safety Devices Inspection (Only CE¹ Version)

MF130 Moulder – Safety Device Inspection

Safety device on the machine which must be checked before every shift:

1. E-STOP button and its circuit inspection

- Use “I” button (B) to start the Main Motor. The motor should start.
- Press the E-STOP button (A) located on the control box. The Main motor should be stopped. Pressing the “I” button should not start the motor until the E-STOP button is released.
- Release E-STOP button. Use “I” button to start the Main Motor. The motor should start.

See Figure 5-1

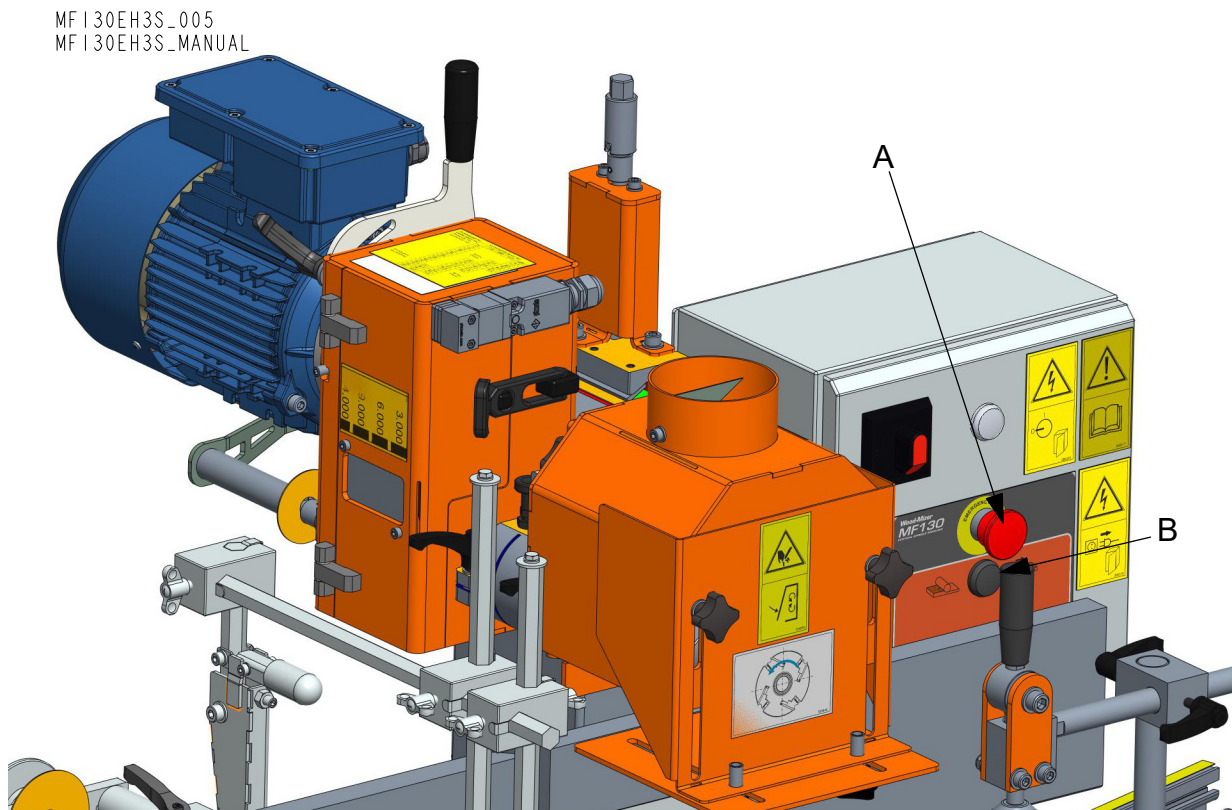

FIG. 5-1

1. Marking of products sold within European Economic Area

2. Belt gear cover safety switch and its circuit inspection.

- Be sure the emergency stop button (A) is released;
- Open the belt gear cover (C).
- Use “I” button (B) to start the cutter. The motor should remain stopped.
- Close belt gear cover (C). Motor should remain stopped until it is restarted with “I” button.

See Figure 5-2

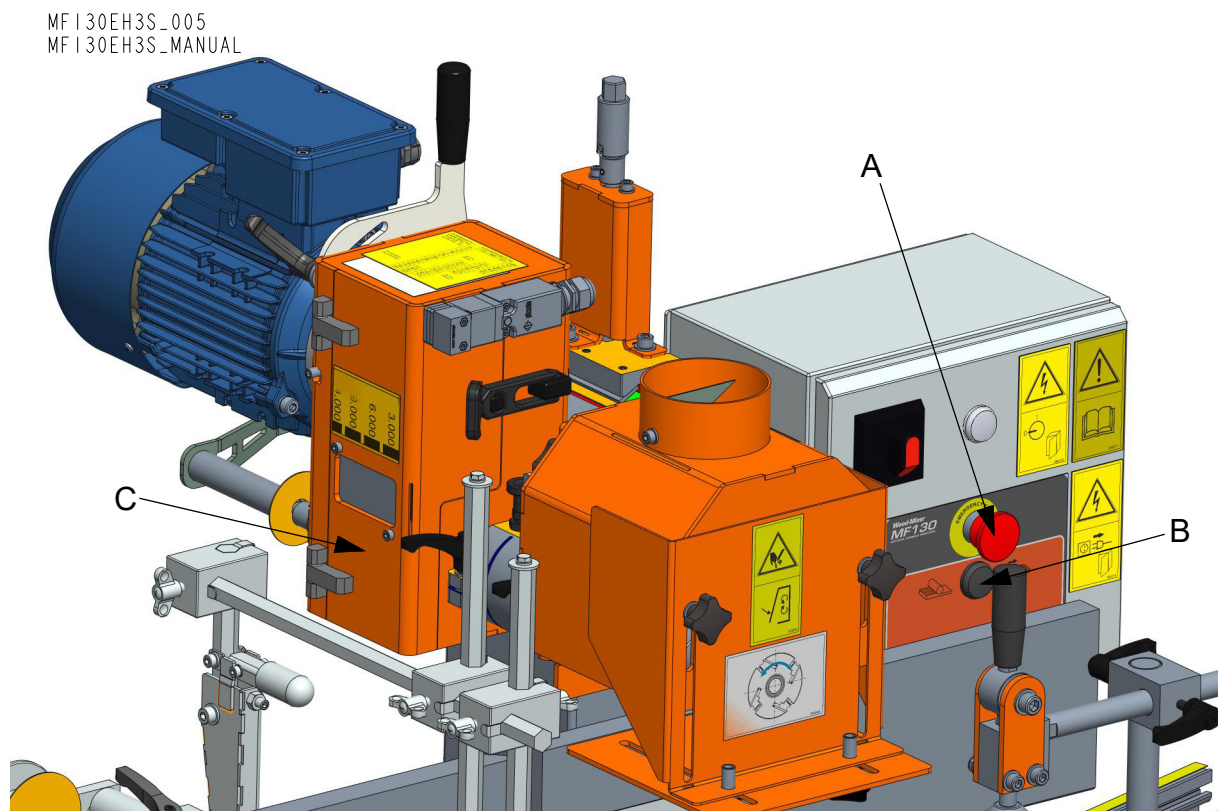

FIG. 5-2

SECTION 6 MF130 SPECIFICATIONS

6.1 Overall dimensions

See figure 6-1. The overall dimensions of the MF130 moulder are shown below (all dimensions in millimeters).

MF130EH3S_004
MF130EH3S_MANUAL

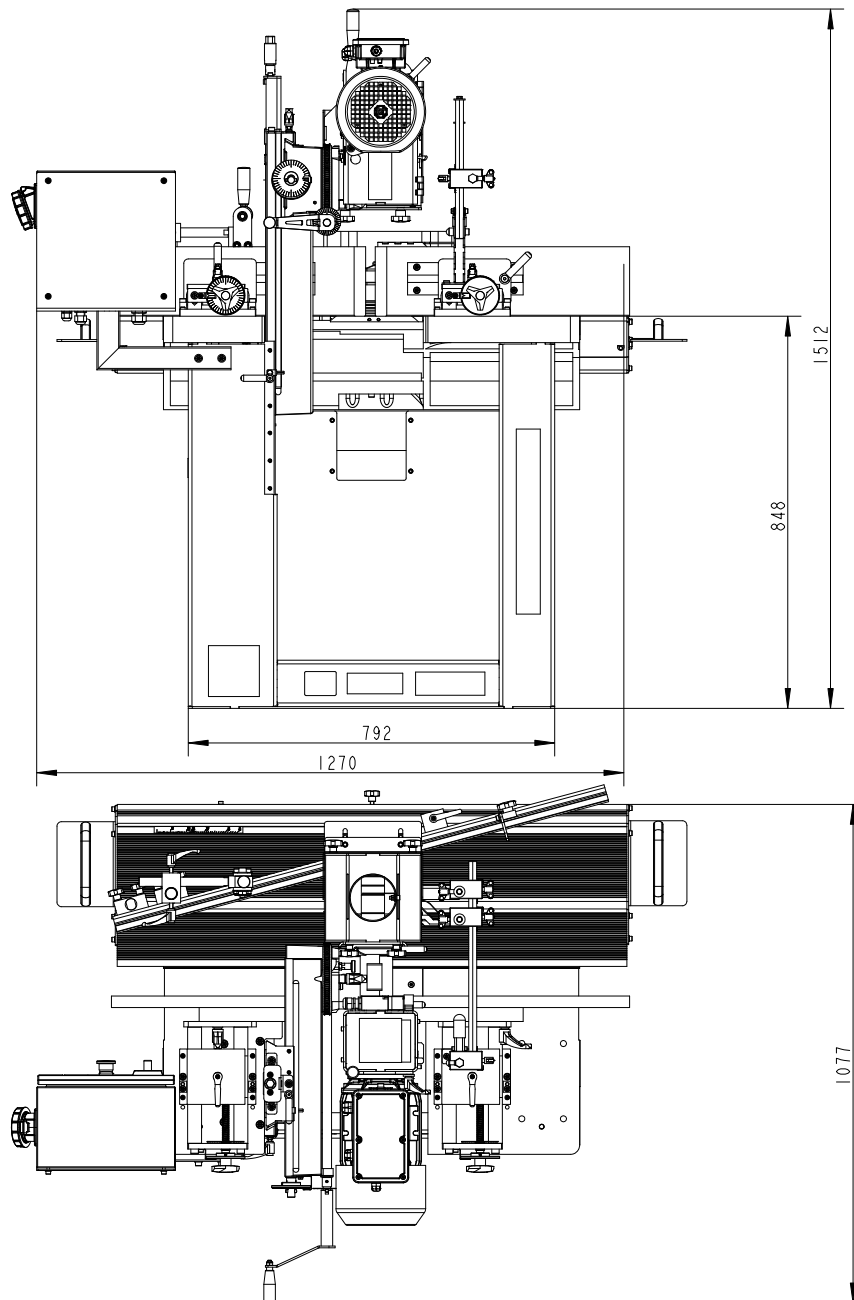

FIG. 6-1 MF130

6 MF130 SPECIFICATIONS

Specifications of the moulder

See table 6-1. Weight of the MF130 moulder are given in the table below.

Moulder type	MF130
Weight	375 kg
Weight with transport box	425 kg

TABLE 6-1

6.2 Specifications of the moulder

See table 6-2. Wood-Mizer MF130 moulder nomenclature is given in the table below.

	Volts
MF130EA3S	1 ph 230V CE
MF130EB3S	3 ph 230V CE
MF130EH3S	3 ph 400V CE

TABLE 6-2

See table 6-3. See the table below for specifications of the MF130 moulder motors.

	MF130EA3S	MF130EB3S	MF130EH3S
Motor Type	Electric Motor	Electric Motor	Electric Motor
Rated Voltage	1x230V	3x230V	3x400V
Rated revolutions	2900r.p.m.	2900r.p.m.	2900r.p.m.
Rated power	2.7 kW	3 kW	3 kW
Wood-Mizer Part No.	533651		
Max. Current	16 A	10.8 A	5.8 A

TABLE 6-3

See table 6-4. The noise level generated by Wood-Mizer MF130 is given in the table below^{1 2 3}

	Noise Level
Moulder MF130 Equipped with electric motor	$L_{WA}(\text{idling}) = 78,3 \text{ dB (A)}$ $L_{WA}(\text{under load}) = 95,7 \text{ dB (A)}$

TABLE 6-4



IMPORTANT! The total value of hand-arm vibration the operator may be exposed to does not exceed 2.5 m/s^2 . The highest root mean square value of weighted acceleration to which the whole operator's body is subjected does not exceed 0.5 m/s^2 .

See table 6-5. A relation between the pattern knife protrusion and the thickness is shown below.

Pattern knife thickness	Pattern knife max. protrusion ¹
3 mm	13 mm
4 mm	21 mm
5mm	29 mm

TABLE 6-5

¹ According to EN 847-1:2005 European Standard

See table 6-6. Rotating tools .

1	30 mm spindle	tools with shaft
Tool Max diameter	195 mm	100 mm
Cutter types	MAN allowed for manual feed	MAN allowed for manual feed
Must be allowed for speeds up to...	9 000 rpm	14 000 rpm

TABLE 6-6

¹ According to EN 847-1:2005 European Standard

6.3 Dust/Chip Extractor Specifications

See Table 6-7. Specifications of the dust/chip extractors used on the MF130 are listed below.

Airflow	1000 m ³ /h
Inlet diameter	1x100mm
Pressure Drop	1.5 kPa (0.25 psi) ¹
Recommended conveying air velocity in the duct	25 m/s

TABLE 6-7

1. The noise level measurement was taken in accordance with PN-EN ISO 3744:2011 Standard . Value for associated uncertainty K=2dB.

2. The measured values refer to emission levels, not necessarily to noise levels in the workplace. Although there is a relation between emission levels and exposure levels, it is not possible to determine with certainty if preventives are needed or are not needed. Factors that influence the actual level of exposure of the workforce include the characteristics of the work room and the other sources of noise etc. i.e. the number of machines and other adjacent processes. Also, the permissible exposure level value may vary depending on country. This information enables the machine's user to better identify hazards and a risk.

3. The total value of hand-arm vibration the operator may be exposed to does not exceed 2.5 m/s². The highest root mean square value of weighted acceleration to which the whole operator's body is subjected does not exceed 0.5 m/s².

¹ The pressure drop between the inlet of the capture device and the connection to the CADES should not exceed 1.5 kPa (for the nominal air flow rate). If the pressure drop exceeds 1.5 kPa the machine might not be compatible with conventional CADES.



IMPORTANT! The dust extractor hoses must be grounded or made with materials not accumulating electrostatic charge.



CAUTION! Always turn on the dust extractor before starting the machine

EC declaration of conformity according to EC Machinery Directive 2006/42/EC, Annex II, 1.A

Manufacturer:

Wood-Mizer Industries sp. z o.o.
Nagórna 114, 62-600 Koło; Poland
Tel. +48 63 26 26 000

This declaration of conformity is issued under the sole responsibility of the manufacturer.

Following machine in our delivered version complies with the appropriate essential safety and health requirements of the EC Machinery Directive 2006/42/EC based on its design and type, as brought into circulation by us. In case of alteration of the machine, not agreed by us, this declaration is no longer valid.

We, the undersigned herewith declare, that:

Designation of the machine: **Spindle moulder Wood-Mizer MF130**
TYPE: MF130
Models: MF130EH3S, MF130EB3S, MF130EA3S
Serial number:

**Is in conformity with the following
EC directives:**

EC Machinery Directive 2006/42/EC
EC Electromagnetic Compatibility Directive
2014/30/EU

**And is in conformity with the following
Harmonized Standards:**

PN-EN ISO 13849-1:2016-02
PN-EN 60204-1: 2018-12

Responsible for Technical Documentation:

Piotr Adamiec / Engineering Manager
Wood-Mizer Industries Sp. z o.o.
62-600 Koło, Nagórna 114, Poland
Tel. +48 63 26 26 000

Place/Date/Authorized Signature:

Koło, 01.04.2021



Title :

Engineering Manager